

harman/kardon

AVR7200

A/V DOLBY DIGITAL RECEIVER

SERVICE MANUAL



CONTENTS

ESD WARNING.....	2	EXPLODED VIEW PARTS LIST.....	19
LEAKAGE TESTING.....	3	BLOCK DIAGRAM.....	22
BASIC SPECIFICATIONS.....	4	DC OFFSET/IDLE CURRENT ADJ.....	23
FRONT PANEL CONTROLS.....	5	BULLETIN HK2003-04.....	24
INFORMATION DISPLAY.....	7	TECH TIP HKTT2003-01.....	25
REAR PANEL CONNECTIONS.....	8	ELECTRICAL PARTS LIST.....	26
REMOTE CONTROL FUNCTIONS.....	11	PCB DRAWINGS.....	77
INSTALLATION/CONNECTIONS.....	14	SEMICONDUCTOR PINOUTS.....	102
TROUBLESHOOTING GUIDE.....	17	SCHEMATICS.....	161
PROCESSOR RESET.....	17	WIRING DIAGRAM.....	186
UNIT EXPLODED VIEW.....	18	PACKAGING PARTS LIST.....	187

harman/kardon, Inc.
250 Crossways Park Dr.
Woodbury, New York 11797

Rev2 12/2005

ELECTROSTATICALLY SENSITIVE (ES) DEVICES

Some semiconductor (solid state) devices can be damaged easily by static electricity. Such components commonly are called Electrostatically Sensitive (ES) Devices. Examples of typical ES devices are integrated circuits and some field effect transistors and semiconductor "chip" components.

The following techniques should be used to help reduce the incidence of component damage caused by static electricity.



1. Immediately before handling any semiconductor component or semiconductor-equipped assembly, drain off any electrostatic charge on your body by touching a known earth ground. Alternatively, obtain and wear a commercially available discharging wrist strap device, which should be removed for potential shock reasons prior to applying power to the unit under test.
2. After removing an electrical assembly equipped with ES devices, place the assembly on a conductive surface such as aluminum foil, to prevent electrostatic charge build-up or exposure of the assembly.
3. Use only a grounded-tip soldering iron to solder or unsolder ES devices.
4. Use only an anti-static solder removal device. Some solder removal devices not classified as "anti-static" can generate electrical charges sufficient to damage ES devices.
5. Do not use freon-propelled chemicals. These can generate electrical charge sufficient to damage ES devices.
6. Do not remove a replacement ES device from its protective package until immediately before you are ready to install it. (Most replacement ES devices are packaged with leads electrically shorted together by conductive foam, aluminum foil or comparable conductive material.)
7. Immediately before removing the protective material from the leads of a replacement ES device, touch the protective material to the chassis or circuit assembly into which the device will be installed.

CAUTION : Be sure no power is applied to the chassis or circuit, and observe all other safety precautions.

8. Minimize bodily motions when handling unpackaged replacement ES devices. (Otherwise harmless motion such as the brushing together of your clothes fabric or the lifting of your foot from a carpeted floor can generate static electricity sufficient to damage an ES devices.

PRODUCT SAFETY NOTICE

Each precaution in this manual should be followed during servicing.

Components identified with the IEC symbol  in the parts list are special significance to safety. When replacing a component identified with , use only the replacement parts designated, or parts with the same ratings or resistance, wattage, or voltage that are designated in the parts list in this manual. Leakage-current or resistance measurements must be made to determine that exposed parts are acceptably insulated from the supply circuit before returning the product to the customer.

LEAKAGE TEST(FOR SERVICE ENGINEERS IN THE U.S.A)

Before returning the unit to the user, perform the following safety checks :

1. Inspect all lead dress to make certain that leads are not pinched or that hardware is not lodged between the chassis and other metal parts in the unit.
2. Be sure that any protective devices such as nonmetallic control knobs, insulating fish-papers, cabinet backs, adjustment and compartment covers or shields, isolation resistor-capacity networks, mechanical insulators, etc. Which were removed for the servicing are properly re-installed.
3. Be sure that no shock hazard exists ; check for leakage current using Simpson Model 229 Leakage Tester, standard equipment item No. 21641, RCA Model WT540A or use alternate method as follows : Plug the power cord directly into a 120 volt AC receptacle (do not use an Isolation Transformer for this test). Using two clip leads, connect a 1500 ohms, 10watt Resistor paralleled by a 0.15uF capacitor, in series with all exposed metal cabinet parts and a known earth ground, such as a water pipe or conduit. Use a VTVM or VOM with 1000 ohms per volt, or higher sensitivity to measure the AC voltage drop across the resistor. (See diagram) Move the resistor connection to each exposed metal part having a return path to the chassis (antenna, metal, cabinet, screw heads, knobs and control shafts, escutcheon, etc.) and measure the AC voltage drop across the resistor. (This test should be performed with the 0.35 volt RMS or more is excessive and indicates a potential shock hazard which must be corrected before returning the unit to the owner.

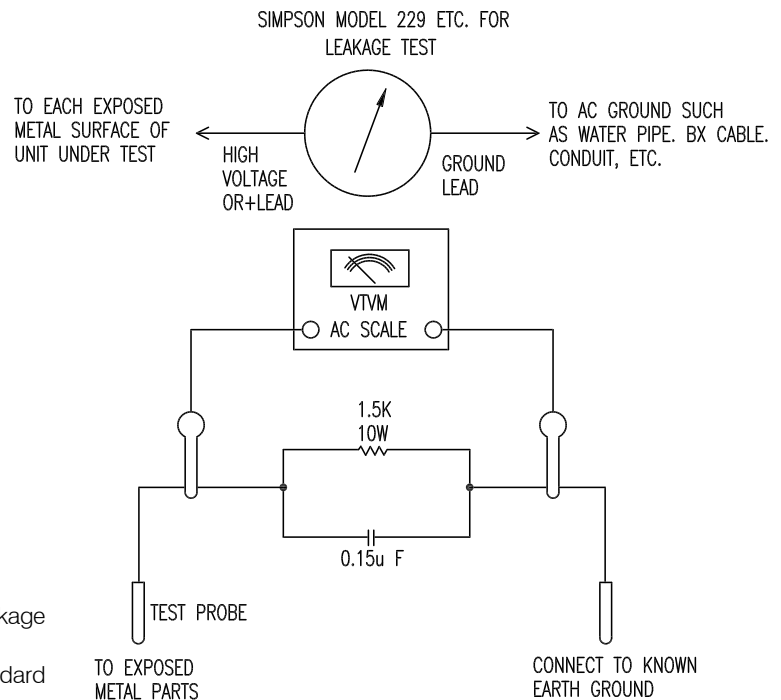

AVR 7200 TECHNICAL SPECIFICATIONS

Audio Section

Stereo Mode	
Continuous Average Power (FTC)	
115 Watts per channel, 20Hz–20kHz, @ <0.07% THD, both channels driven into 8 ohms	
Seven-Channel Surround Modes	
Power per Individual Channel	
Front L&R channels:	
100 Watts per channel	
@ <0.07% THD, 20Hz–20kHz into 8 ohms	
Center channel:	
100 Watts @ <0.07% THD, 20Hz–20kHz into 8 ohms	
Surround (L & R Side, L & R back) channels:	
100 Watts per channel	
@ <0.07% THD, 20Hz–20kHz into 8 ohms	
Input Sensitivity/Impedance	
Linear (High-Level)	200mV/47k ohms
Signal-to-Noise Ratio (IHF-A)	95dB
Surround System Adjacent Channel Separation	
Pro Logic I/II	40dB
Dolby Digital (AC-3)	55dB
DTS	55dB
Frequency Response	
@ 1W (+0dB, –3dB)	10Hz – 100kHz
High Instantaneous Current Capability (HCC)	±75 Amps
Transient Intermodulation Distortion (TIM)	Unmeasurable
Slew Rate	40V/μsec

FM Tuner Section

Frequency Range	87.5–108.0MHz
Usable Sensitivity	IHF 1.3μV/13.2dB
Signal-to-Noise Ratio	Mono/Stereo 70/68dB
Distortion	Mono/Stereo 0.2/0.3%
Stereo Separation	40dB @ 1kHz
Selectivity	±400kHz, 70dB
Image Rejection	80dB
IF Rejection	90dB

AM Tuner Section

Frequency Range	520–1710kHz
Signal-to-Noise Ratio	45dB
Usable Sensitivity	Loop 500μV
Distortion	1kHz, 50% Mod 0.8%
Selectivity	±10kHz, 30dB

Video Section

Television Format	NTSC
Input Level/Impedance	1Vp-p/75 ohms
Output Level/Impedance	1Vp-p/75 ohms
Video Frequency Response (Composite and S-Video)	10Hz–8MHz (–3dB)
Video Frequency Response (Component Video)	10Hz–50MHz (–3dB)

General

Power Requirement	AC 120V/60Hz
Power Consumption	112W idle, 1210W maximum (7 channels driven)
Dimensions	Width 17.3 inches (440mm) Height 7.6 inches (192mm) Depth 20.5 inches (520mm)
Weight	61 lb (29.9kg)

Depth measurement includes knobs, buttons and terminal connections.
Height measurement includes feet and chassis.
All features and specifications are subject to change without notice.

Harman Kardon and Power for the Digital Revolution are registered trademarks of Harman International Industries, Incorporated.

IIIIZeSet is a trademark of Harman International Industries, Incorporated (patent no. 5,386,478).

*Manufactured under license from Dolby Laboratories. "Dolby," "Pro Logic," "Pro Logic II" and the Double-D symbol are trademarks of Dolby Laboratories. Confidential Unpublished Works. ©1992–1999 Dolby Laboratories, Inc. All rights reserved.

DTS, DTS Surround, DTS-ES and DTS Neo:6 are registered trademarks of Digital Theater Systems, Inc.

UltraStereo is a trademark of UltraStereo Corp.

VMAx is a registered trademark of Harman International Industries, Incorporated, and is an implementation of Cooper Bauck Transaural Stereo under patent license.

Logic 7 is a registered trademark of Harman International Industries, Incorporated.

HDCD system manufactured under license from Pacific Microsonics, Inc. This product is covered by one or more of the following: in the USA: 5,479,168; 5,638,074; 5,640,161; 5,808,574; 5,838,274; 5,854,600; 5,864,311; 5,872,531; and in Australia: 669114. Other patents pending.

A-BUS and A-BUS Ready are registered trademarks of Leisure Tech Electronics Pty Ltd Australia.

FRONT-PANEL CONTROLS

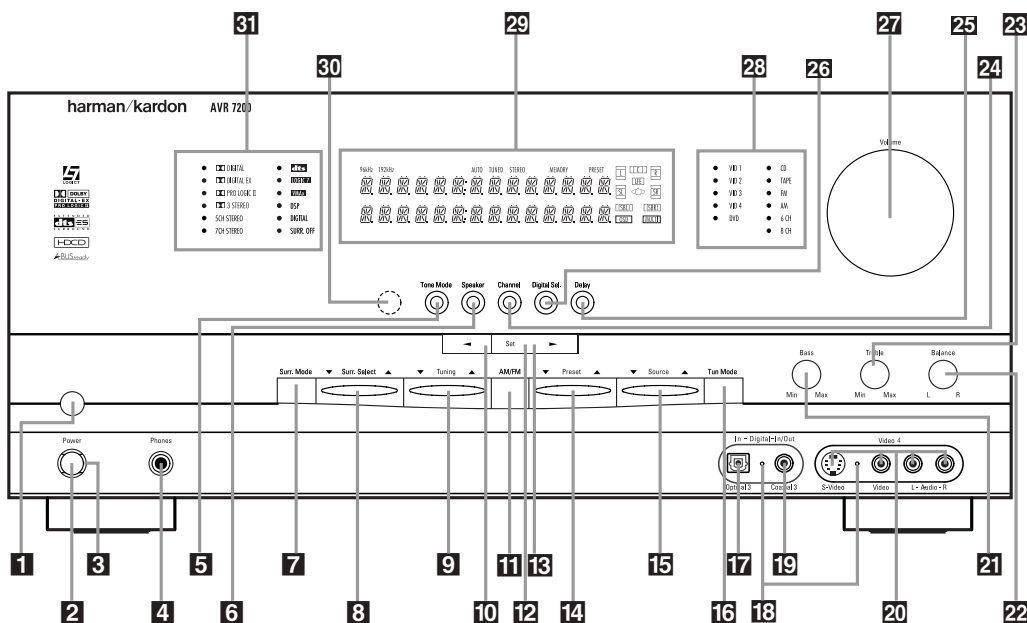

- 1** Main Power Switch
- 2** System Power Control
- 3** Power Indicator
- 4** Headphone Jack
- 5** Tone Mode
- 6** Speaker Selector
- 7** Surround Mode Group Selector
- 8** Surround Mode Selector
- 9** Tuning Selector
- 10** ◀ Button
- 11** Tuner Band Selector
- 12** Set Button
- 13** ▶ Button
- 14** Preset Station Selector
- 15** Input Source Selector
- 16** Tuner Mode Selector
- 17** Optical 3 Digital Input
- 18** Input/Output Status Indicator
- 19** Coaxial 3 Digital Input/Output
- 20** Video 4 Input/Output Jacks
- 21** Bass Control
- 22** Balance Control
- 23** Treble Control
- 24** Channel Adjust Selector
- 25** Delay Adjust Selector
- 26** Digital Input Selector
- 27** Volume Control
- 28** Input Indicators
- 29** Main Information Display
- 30** Remote Sensor Window
- 31** Surround Mode Indicators

1 Main Power Switch: Press this button to apply power to the AVR 7200. When the switch is pressed in, the unit is placed in a Standby mode, as indicated by the amber **Power Indicator 3** surrounding the **System Power Control 2**. This button **MUST** be pressed in to operate the unit. To turn the unit off and prevent the use of the remote control, this switch should be pressed until it pops out from the front panel so that the word "OFF" may be read at the top of the switch.

NOTE: This switch is normally left in the "ON" position.

2 System Power Control: When the **Main Power Switch 1** is "ON"; press this button to turn on the AVR 7200; press it again to turn the unit off. Note that the **Power Indicator 3** surrounding the switch will turn green when the unit is on.

3 Power Indicator: This LED will be lit in amber when the unit is in the Standby mode to signal that the

unit is ready to be turned on. When the unit is in operation, the indicator will turn green.

4 Headphone Jack: This jack may be used to listen to the AVR 7200's output through a pair of headphones. Be certain that the headphones have a standard 1/4" stereo phone plug. The main room speakers will automatically be turned off when the headphone jack is in use.

5 Tone Mode: This button allows you to remove the tone controls (Treble, Bass and Balance) from the signal path. The first press of the button displays a **TONE IN** message in the **Main Information Display 29**. If you wish to set the tone controls to "flat," without any treble or bass alteration, press the **◀ or ▶ Selector Buttons 10/13** so that **TONE OUT** appears in the **Lower Display Line B**.

6 Speaker Selector: Press this button to begin the process of configuring the AVR 7200 for the type of

speakers it is being used with. For complete information on configuring the speaker settings, see page 21.

7 Surround Mode Group Selector: Press this button to select the top-level group of surround modes. Each press of the button will select a major mode grouping in the following order:

- Dolby Modes → DTS Digital Modes → VMAx Modes
- DSP Modes → Stereo Modes → Logic 7 Modes

Once the button is pressed so that the name of the desired surround mode group appears in the on-screen display and in the **Lower Display Line B**, press the **Surround Mode Selector 8** to cycle through the individual modes available. For example, press this button to select Dolby modes, and then press the **Surround Mode Selector 8** to choose from the various mode options.

FRONT - PANEL CONTROLS

8 Surround Mode Selector: Press this button to select from among the available surround mode options for the major mode group selected. The specific modes will vary based on the number of speakers available, the major mode group and whether the input source is digital or analog. For example, press the **Surround Mode Group Selector 7** to select a major mode grouping such as Dolby or Logic 7, and then press this button to see the specific mode choices that are available. For more information on mode selection, see page 28.

9 Tuning Selector: Press the left side of the button to tune lower-frequency stations and the right side of the button to tune higher-frequency stations. When a station with a strong signal is reached, the **TUNED Indicator 11** will be lit in the **Main Information Display 29**.

10 ◀ Button: When making system configuration changes using the front-panel controls, press this button to scroll left through the available choices for the option being adjusted.

11 Tuner Band Selector: Pressing this button will automatically switch the AVR 7200 to the Tuner mode. Pressing it again will switch between the AM and FM frequency bands. (See page 32 for more information on the tuner.)

12 Set Button: When making system configuration changes using the front-panel controls, press this button to enter a setting into the unit's memory.

13 ▶ Button: When making system configuration changes using the front-panel controls, press this button to scroll right through the available choices for the option being adjusted.

14 Preset Station Selector: Press this button to scroll up or down through the list of stations that have been entered into the preset memory. (See page 32 for more information on tuner programming.)

15 Input Source Selector: Press this button to change the input by scrolling up or down through the list of input sources.

16 Tuner Mode Selector: Press this button to select Auto or Manual tuning. When the button is pressed so that the **AUTO Indicator J** lights, the tuner will search for the next station with an acceptable signal when the **Tuning Selector 9 23 E** is pressed. When the button is pressed so that the **AUTO Indicator J** is not lit, each press of the **Tuning Selector 9 23 E** will increase the frequency. This button may also be used to switch between Stereo and Mono modes for FM radio reception. When weak reception is encountered, press the button until the **Stereo Indicator H** goes out to switch to Mono reception. Press and hold again to switch back to Stereo mode. (See page 32 for more information on using the tuner.)

17 Optical 3 Digital Input: Connect the optical digital output of an audio or video product to this jack.

18 Input/Output Status Indicator: This LED indicator will normally light green to show that the front-panel **Coaxial 3 Digital Input/Output Jack 19** or the front-panel **Video 4 Input/Output Jacks 20** are operating as inputs. When these jacks are configured for use as an output, the indicator will turn red to show that the jack may be used for recording. (See page 32 for more information on configuring the front-panel jacks as outputs, rather than inputs.)

19 Coaxial 3 Digital Input/Output: Connect the coaxial digital input or output for a digital audio product such as a portable audio player or video game to this jack. The jack is normally an input, but may be switched to an output for recording using the menu system. See page 32 for more information.

20 Video 4 Input/Output Jacks: These audio/video jacks may be used for temporary connection to video games or portable audio/video products such as camcorders and portable audio players. These jacks are normally inputs, but may be switched to outputs for recording using the menu system. See page 32 for more information.

21 Bass Control: Use this control to boost or reduce the low-frequency output of the left/right front channels by as much as ± 10 dB. Set this control as you find suitable to adjust to your specific taste or room acoustics.

22 Balance Control: Use this control to change the relative volume for the front left/right channels.

NOTE: When multichannel surround modes are in use, this control should be at the midpoint, or "12 o'clock" position for proper operation.

23 Treble Control: Use this control to boost or reduce the high-frequency output of the left/right front channels by as much as ± 10 dB. Set this control as you find suitable to adjust to your specific taste or room acoustics.

24 Channel Adjust Selector: Press the button to begin the process of adjusting the channel level outputs using the source currently playing through your AVR. For complete information on adjusting the channel output level, see page 33.

25 Delay Adjust Selector: Press this button to begin the process of adjusting the delay settings for Dolby surround modes. See page 23 for more information on delay adjustments.

26 Digital Input Selector: Press this button to begin the process of selecting a digital source for use with the currently selected input. Once the button has been pressed, use the **◀ or ▶ Buttons 10 13** to choose the desired input and then press the **Set Button 12**

to enter the setting into the unit's memory. See page 30 for more information on digital audio.

27 Volume Control: Turn this knob clockwise to increase the volume, counterclockwise to decrease the volume. If the AVR 7200 is muted, adjusting volume control will automatically release the unit from the silenced condition.

28 Input Indicators: A green LED will light to the left of the input that is currently the input source for the AVR 7200.

29 Main Information Display: This display delivers messages and status indications to help you operate the receiver. (See page 7 for a complete explanation of the Information Display.)

30 Remote Sensor Window: The sensor behind this window receives infrared signals from the remote control. Aim the remote at this area and do not block or cover it unless an external remote sensor is installed.

31 Surround Mode Indicators: These LEDs will light to show the surround mode and digital bitstream in use. Note that depending on the specific combination of input sources and surround mode selected, more than one indicator may light. (See page 28 for more information.)

FRONT-PANEL INFORMATION DISPLAY

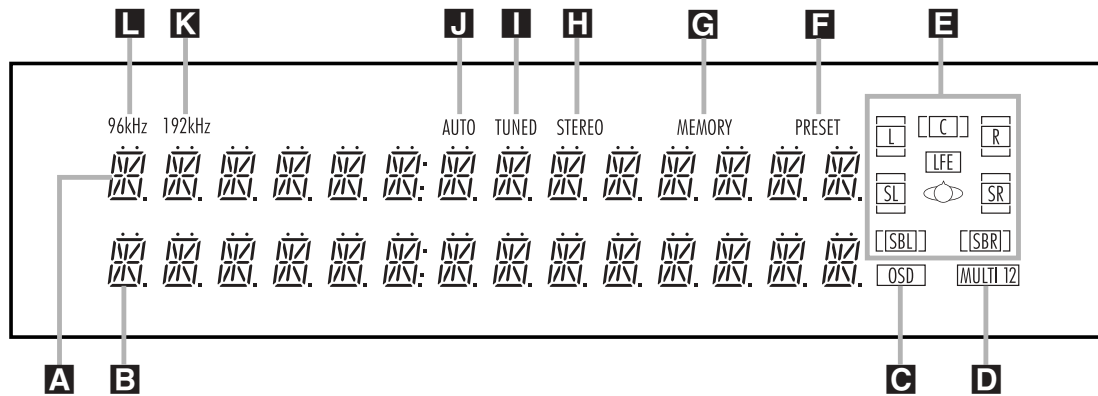

- A** Upper Display Line
- B** Lower Display Line
- C** OSD Indicator
- D** Multiroom Indicator
- E** Speaker/Channel Input Indicators

- F** PRESET Indicator
- G** MEMORY Indicator
- H** STEREO Indicator
- I** TUNED Indicator
- J** AUTO Indicator

- K** 192kHz Indicator
- L** 96kHz Indicator

A Upper Display Line: Depending on the unit's status, a variety of messages will appear here. In normal operation, the current audio and video input source information will appear on this line.

B Lower Display Line: Depending on the unit's status, a variety of messages will appear here. In normal operation, the current surround mode name will appear on this line.

C OSD Indicator: When the OSD system is in use, this indicator lights to remind you that the other indicators in this display do not function when the On-Screen Display is being used.

D Multiroom Indicator: This indicator lights when the multiroom system is active. It will remain lit when the multiroom system is in use even though the main room system is in the Standby mode and all other indicators are dark. (See page 36 for more information on the Multiroom system.)

E Speaker/Channel Input Indicators: These indicators are multipurpose, indicating either the speaker type selected for each channel or the incoming data-signal configuration. The left, center, right, right surround, left surround, right surround back and left surround back speaker indicators are composed of three boxes, while the subwoofer is a single box. The center box lights when a "Small" speaker is selected, and the two outer boxes light when "Large" speakers are selected. When none of the boxes are lit for the center, surround or subwoofer channels, no speaker has been selected for one

of those positions. (See page 21 for more information on speaker setup.) The letters inside each of the center boxes display the active input channels. For standard analog inputs, only the L and R will light, indicating a stereo input. When a digital source is playing, the indicators will light to display the channels being received at the digital input. When the letters flash, the digital input has been interrupted. (See page 31 for more information on the Channel Indicators.)

F PRESET Indicator: This indicator lights when the tuner is in use to show that the preset number for the current station being listened to appears in the Upper Display Line. (See page 32 for more information on tuner presets.)

G MEMORY Indicator: This indicator flashes when entering presets and other information into the tuner's memory.

H STEREO Indicator: This indicator lights when an FM station is being tuned in stereo.

I TUNED Indicator: This indicator lights when a station is being received with sufficient signal strength to provide acceptable listening quality.

J AUTO Indicator: This indicator lights when the tuner's Auto mode is in use.

K 192kHz Indicator: This indicator lights when the input source has a 192kHz bit rate.

L 96kHz Indicator: This indicator lights when the input source has a 96kHz bit rate.

REAR-PANEL CONNECTIONS

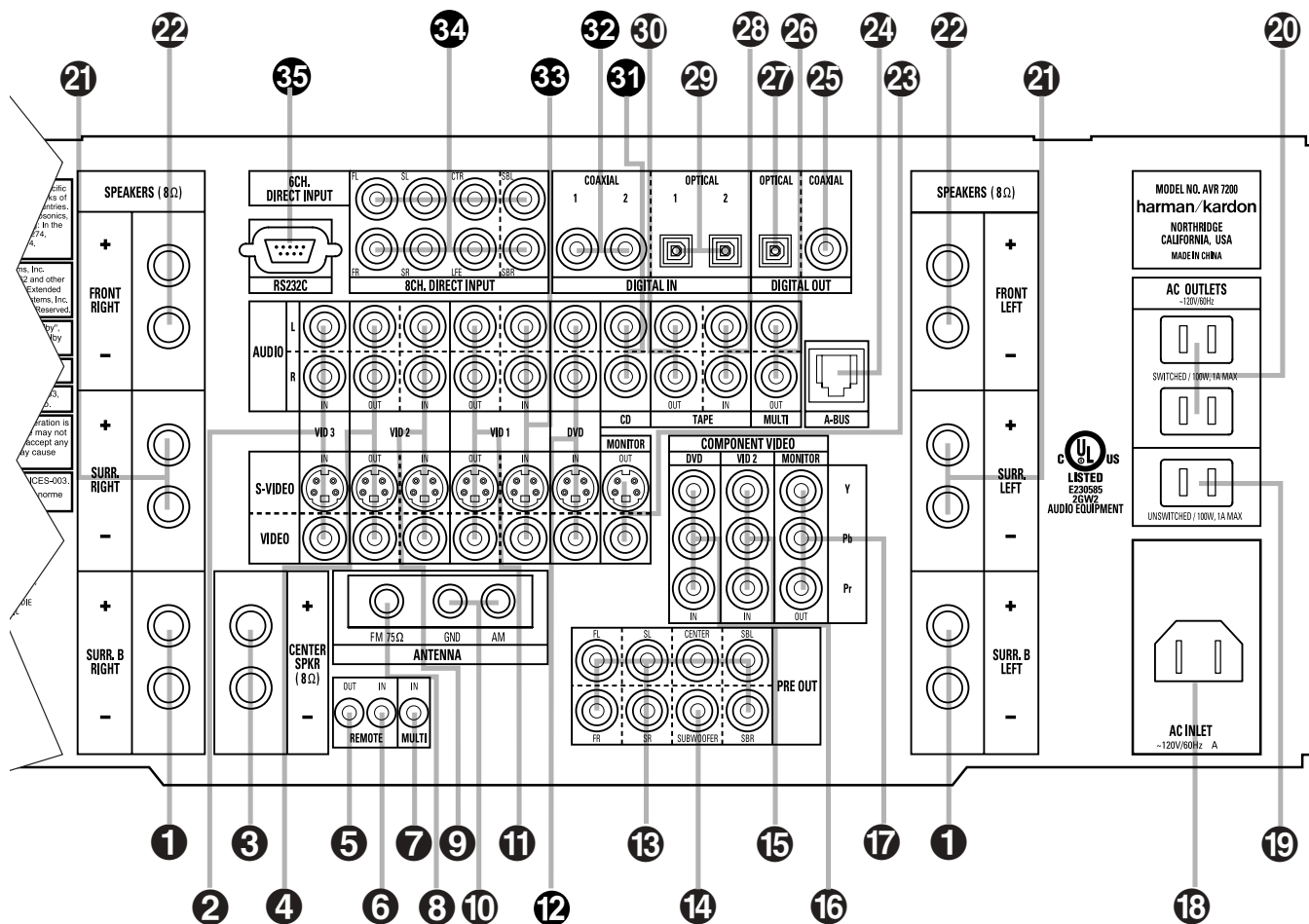

- 1 Surround Back/Multiroom Speaker Outputs
- 2 Video 3 Inputs
- 3 Center Speaker Outputs
- 4 Video 2 Outputs
- 5 Remote IR Output
- 6 Remote IR Input
- 7 Multiroom IR Input
- 8 FM Antenna Terminal
- 9 Video 2 Inputs
- 10 AM Antenna Terminals
- 11 Video 1 Outputs
- 12 DVD Inputs

- 13 Preamp Outputs
- 14 Subwoofer Output
- 15 DVD Component Video Inputs
- 16 Video 2 Component Video Inputs
- 17 Component Video Monitor Outputs
- 18 AC Power Cord Jack
- 19 Unswitched AC Accessory Outlet
- 20 Switched AC Accessory Outlets
- 21 Surround Speaker Outputs
- 22 Front Speaker Outputs
- 23 Video Monitor Outputs
- 24 A-BUS Connector

- 25 Coaxial Digital Audio Output
- 26 Multiroom Audio Outputs
- 27 Optical Digital Audio Output
- 28 Tape Inputs
- 29 Optical Digital Audio Inputs
- 30 Tape Outputs
- 31 CD Audio Inputs
- 32 Coaxial Digital Audio Inputs
- 33 Video 1 Inputs
- 34 8-Channel Direct Inputs
- 35 RS-232 Port

NOTE: To assist in making the correct connections for multichannel input, output and speaker connections, all connection jacks and terminals are color-coded in conformance with the latest CEA standards as follows:

Front Left: White
Front Right: Red

Center: Green
Surround Left: Blue
Surround Right: Gray
Surround Back Left: Brown
Surround Back Right: Tan
Subwoofer: Purple
Digital Audio: Orange

Composite Video: Yellow
Component Video "Y": Green
Component Video "Pr": Red
Component Video "Pb": Blue

REAR-PANEL CONNECTIONS

1 Surround Back/Multiroom Speaker Outputs:

These speaker terminals are normally used to power the surround back left/surround back right speakers in a 7.1 channel system. However, they may also be used to power the speakers in a second zone, which will receive the output selected for a multiroom system. To change the output fed to these terminals from the default of the Surround Back speakers to the Multiroom Output, you must change a setting in the Advanced Menu of the OSD system. See page 34 for more information on configuring this speaker output. In normal surround system use, the brown and black terminals are the surround back left channel positive (+) and negative (-) connections and the tan and black terminals are the surround back right positive (+) and negative (-) terminals. For multiroom use, connect the brown and black SBL terminals to the red and black connections on the left remote zone speaker and connect the tan and black SBR terminals to the red and black terminals on the right remote zone speaker.

2 Video 3 Inputs: Connect the analog audio and composite or S-Video PLAY/OUT jacks of a VCR or other video source to these jacks.

3 Center Speaker Outputs: Connect these outputs to the matching + and - terminals on your center channel speaker. In conformance with the new CEA color-code specification, the green terminal is the positive (+) terminal that should be connected to the red (+) terminal on speakers with the older color-coding. Connect the black (-) terminal on the AVR to the black (-) terminal on your speaker. (See page 15 for more information on speaker polarity.)

4 Video 2 Outputs: Connect the analog audio and composite or S-Video REC/IN jacks of a VCR or other video recording device such as a DVD recorder or PVR to these jacks.

5 Remote IR Output: This connection permits the IR sensor in the receiver to serve other remote controlled devices. Connect this jack to the "IR IN" jack on Harman Kardon (or other compatible) equipment.

6 Remote IR Input: If the AVR 7200's front-panel IR sensor is blocked due to cabinet doors or other obstructions, an external IR sensor may be used. Connect the output of the sensor to this jack.

7 Multiroom IR Input: Connect the output of an IR sensor in a remote room to this jack to operate the AVR 7200's multiroom control system.

8 FM Antenna Terminal: Connect the supplied indoor or an optional external FM antenna to this terminal.

9 Video 2 Inputs: Connect the analog audio and composite or S-Video PLAY/OUT jacks of a VCR or other video source to these jacks.

10 AM Antenna Terminals: Connect the AM loop antenna supplied with the receiver to these terminals. If an external AM antenna is used, make connections to the AM and GND terminals in accordance with the instructions supplied with the antenna.

11 Video 1 Outputs: Connect the analog audio and composite or S-Video REC/IN jacks of a VCR or other video recording device such as a DVD recorder or PVR to these jacks.

12 DVD Inputs: Connect the analog audio and composite or S-Video outputs of a DVD player or other video source to these jacks.

13 Preamp Outputs: Connect these jacks to an optional, external power amplifier for applications where higher power is desired.

14 Subwoofer Output: Connect this jack to the line-level input of a powered subwoofer. If an external subwoofer amplifier is used, connect this jack to the subwoofer amplifier input.

15 DVD Component Video Inputs: Connect the Y/Pr/Pb component video outputs of a DVD player to these jacks.

16 Video 2 Component Video Inputs: Connect the Y/Pr/Pb component video outputs of an HDTV set-top converter, satellite receiver or other video source device with component video outputs to these jacks.

17 Component Video Monitor Outputs: Connect these outputs to the component video inputs of a video projector or monitor. When a source connected to one of the **Component Video Inputs 15 16** is selected, the signal will be sent to these jacks.

18 AC Power Cord Jack: Connect the AC power cord to this jack when the installation is complete. To ensure safe operation, use only the power cord supplied with the unit. If a replacement is required, it must be of the same type and capacity.

19 Unswitched AC Accessory Outlet: This outlet may be used to power any AC device. The power will remain on at this outlet regardless of whether the AVR 7200 is on or off.

20 Switched AC Accessory Outlets: These outlets may be used to power any device you wish to have turned on when the AVR 7200 is turned on with the **System Power Control Button 2**.

NOTE: The total power consumption of all devices connected to the accessory outlets should not exceed 100 watts.

21 Surround Speaker Outputs: Connect these outputs to the matching + and - terminals on your surround channel speakers. In conformance with the new

CEA color-code specification, the blue terminal is the positive (+) terminal that should be connected to the red (+) terminal on the Surround Left speaker with older color-coding, while the gray terminal should be connected to the red (+) terminal on the Surround Right speaker with the older color-coding. Connect the black (-) terminal on the AVR to the matching black (-) terminals for each surround speaker. (See page 15 for more information on speaker polarity.)

22 Front Speaker Outputs: Connect these outputs to the matching + or - terminals on your left and right speakers. When making speaker connections, always make certain to maintain correct polarity by connecting the color-coded (white for front left and red for front right) (+) terminals on the AVR 7200 to the red (+) terminals on the speakers and the black (-) terminals on the AVR 7200 to the black (-) terminals on the speakers. (See page 15 for more information on speaker polarity.)

23 Video Monitor Outputs: Connect these jacks to the composite or S-Video input of a TV monitor or video projector to view the on-screen menus and the output of any standard video source selected by the receiver's video switcher.

24 A-BUS Connector: Connect this jack to an optional A-BUS-certified remote room keypad or amplifier to extend the multiroom capabilities of your AVR 7200. See pages 16 and 36 for more information on A-BUS.

25 Coaxial Digital Audio Output: Connect this jack to the coaxial digital audio input of a CD-R/RW, MiniDisc or other digital recorder.

26 Multiroom Audio Outputs: Connect these jacks to the optional external audio power amplifier and video distribution system that delivers the source selected for multizone distribution.

27 Optical Digital Audio Output: Connect this jack to the optical digital audio input connector on a CD-R/RW, MiniDisc or other digital recorder.

28 Tape Inputs: Connect these jacks to the PLAY/OUT jacks of an audio recorder.

29 Optical Digital Audio Inputs: Connect the optical digital audio output from a DVD player, HDTV receiver, the S/P-DIF output of a compatible computer sound card playing MP3 files or streams, LD player or CD player to these jacks. The signal may be a Dolby Digital signal, a DTS signal or a standard PCM digital source.

30 Tape Outputs: Connect these jacks to the RECORD/INPUT jacks of an audio recorder.

31 CD Audio Inputs: Connect these jacks to the analog audio output of a compact disc player or CD changer.

REAR-PANEL CONNECTIONS

32 Coaxial Digital Audio Inputs: Connect the coax digital audio output from a DVD player, HDTV receiver, the S/P-DIF output of a compatible computer sound card playing MP3 files or streams, LD player or CD player to these jacks. The signal may be a Dolby Digital signal, DTS signal or a standard PCM digital source. Do not connect the RF digital output of an LD player to these jacks.

33 Video 1 Inputs: Connect the analog audio and composite or S-Video PLAY/OUT jacks of a VCR or other video source to these jacks.

34 8-Channel Direct Inputs: These jacks are used for connection to source devices such as DVD-Audio or SACD players with discrete analog outputs. Depending on the source device in use, all eight jacks may be used, though in many cases only connections to the front left/right, center, surround left/right and LFE (sub-woofer input) jacks will be used for standard 5.1 audio signals.

35 RS-232 Port: This jack is used to enable the AVR 7200 to be controlled by an external computer or programmable remote system that uses RS-232 commands. Due to the complexity of RS-232 connections, we recommend that they be made only by a trained and qualified custom installer. See page 36 for more information on the RS-232 control port.

MAIN REMOTE CONTROL FUNCTIONS

- 1 Power Off Button
- 2 Power On Button
- 3 LCD Information Display
- 4 Input Selectors
- 5 AVR Selector
- 6 Test Button
- 7 DSP Surround Mode Selector
- 8 Logic 7 Mode Select Button
- 9 Direct Button
- 10 Clear Button
- 11 Numeric Keys
- 12 Tuning Mode Button
- 13 Channel Select Button
- 14 Navigation Button
- 15 Digital Select Button
- 16 Set Button
- 17 Transport Play Buttons
- 18 Volume Up/Down Buttons
- 19 Transport Fast-Play/Scan Buttons
- 20 Main Transport Controls
- 21 Track Skip Up/Down Buttons
- 22 Preset Up/Down Button
- 23 Tuning Up/Down Button
- 24 Disc Skip Button
- 25 Program Button
- 26 Light Button
- 27 Multiroom
- 28 Macro Buttons
- 29 Sleep Button
- 30 Night Mode Button
- 31 OSD Button
- 32 Mute Button
- 33 AM/FM Tuner Select
- 34 Channel Up/Down Selector
- 35 Delay Select Button
- 36 Speaker Select Button
- 37 Memory Button
- 38 Stereo Mode Select Button
- 39 DTS Neo:6 Mode Select Button
- 40 DTS Digital Mode Select Button
- 41 Dolby Mode Select Button
- 42 6/8-Channel Input Select
- 43 SPL Select Button
- 44 EzSet Microphone Sensor
- 45 Lens

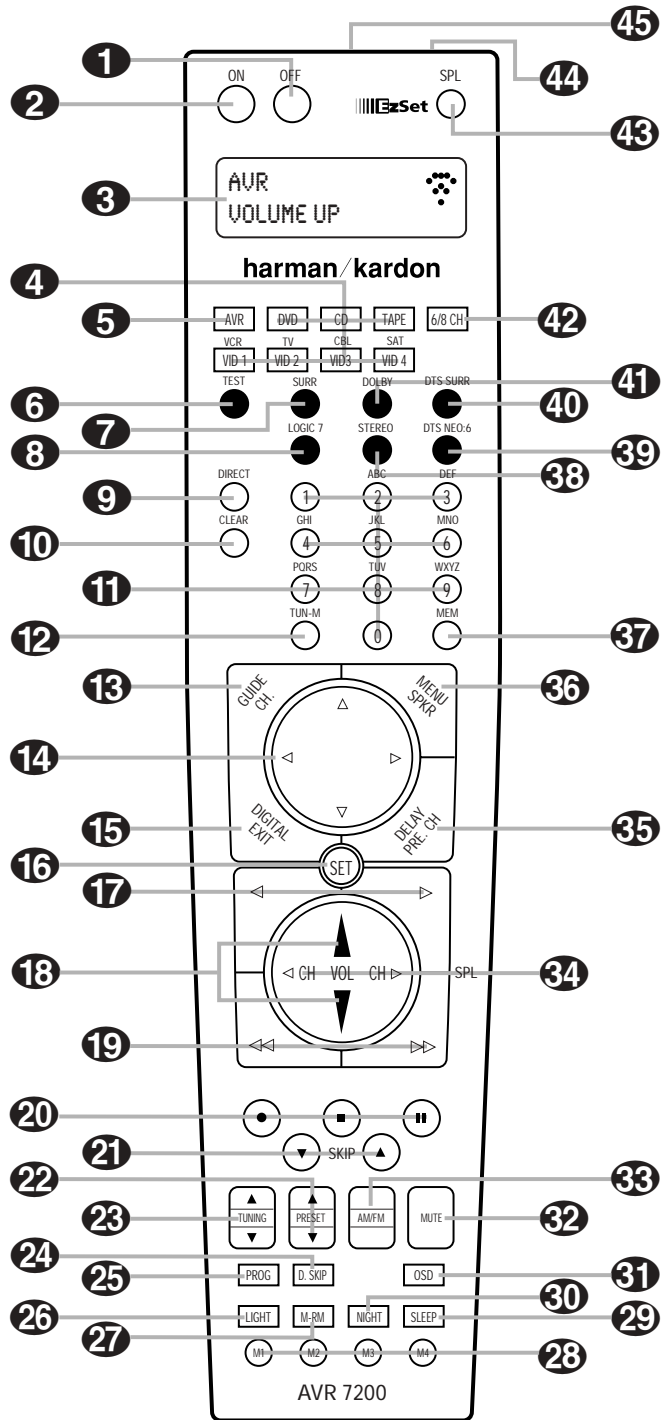

NOTES:

- The function names shown here are each button's feature when used with the AVR 7200. Most buttons have additional functions when used with other devices. When a button is pressed, the function name will appear in the bottom line of the LCD Information Display **3**.
- The jack on the upper right side of the remote is reserved for future use. Do not remove the plug provided or connect any device to the jack.

MAIN REMOTE CONTROL FUNCTIONS

IMPORTANT NOTE: The AVR 7200's remote may be programmed to control up to eight devices, including the AVR 7200. Before using the remote, it is important to remember to press the **Input Selector Button 4** that corresponds to the unit you wish to operate. In addition, the AVR 7200's remote is shipped from the factory to operate the AVR 7200 and most Harman Kardon CD or DVD players and cassette decks. The remote is also capable of operating a wide variety of other products using the control codes that are part of the remote. Before using the remote with other products, follow the instructions on pages 38 – 40 to program the proper codes for the products in your system.

It is also important to remember that many of the buttons on the remote take on different functions, depending on the product selected using the Device Control Selectors. The descriptions shown here primarily detail the functions of the remote when it is used to operate the AVR 7200.

- 1 Power Off Button:** Press this button to place the AVR 7200 or a selected device in the Standby mode. Note that this will turn off the main room functions, but if the Multiroom system is activated, it will continue to function.
- 2 Power On Button:** Press this button to turn on the power to a device selected by first pressing one of the **Input Selectors 4**.
- 3 LCD Information Display:** This two-line screen displays various information depending on the commands that have been entered into the remote.
- 4 Input Selectors:** Pressing one of these buttons will perform three actions at the same time. First, if the AVR 7200 is not turned on, this will power up the unit. Next, it will select the source shown on the button as the input to the AVR 7200. Finally, it will change the remote control so that it controls the device selected. After pressing one of these buttons you must press the **AVR Selector Button 5** again to operate the AVR 7200's functions with the remote.
- 5 AVR Selector:** Pressing this button will switch the remote so that it will operate the AVR 7200's functions. If the AVR 7200 is in the Standby mode, it will also turn the AVR 7200 on.
- 6 Test Button:** Press this button to begin the sequence used to calibrate the AVR 7200's output levels. (See page 24 for more information on calibrating the AVR 7200.)
- 7 DSP Surround Mode Selector:** Press this button to select from among the available DSP surround modes. (See page 29 for more information on the Theater, Hall and VMaX modes.)

- 8 Logic 7 Mode Select Button:** Press this button to select from among the available Logic 7 surround modes. (See page 29 for the available Logic 7 options.)
- 9 Direct Button:** Press this button when the tuner is in use to start the sequence for direct entry of a station's frequency. After pressing the button, simply press the proper **Numeric Keys 11** to select a station. (See page 32 for more information on the tuner.)
- 10 Clear Button:** When programming the remote or using the EzSet feature, press this button to cancel the current function. When using the remote to enter frequencies for direct tuner access, press this button to clear previous entries.
- 11 Numeric Keys:** These buttons serve as a ten-button numeric keypad to enter tuner preset positions. They are also used to select channel numbers when TV, Cable or SAT has been selected on the remote, or to select track numbers on a CD, DVD or LD player, depending on how the remote has been programmed. These buttons are also used to enter letters and numbers when renaming devices in the LCD Information Display. (See page 45 for more information on renaming devices and keys.)
- 12 Tuning Mode:** Press this button when the tuner is in use to select between automatic tuning and manual tuning. When the button is pressed so that **MANUAL TUNING** appears in the **Lower Display Line B**, pressing the **Tuning Selector 9 23** will move the frequency up or down in single-step increments. When the FM band is in use, pressing this button for manual tuning when a station's signal is weak will change to monaural reception. (See page 32 for more information.)
- 13 Channel Select Button:** This button is used to start the process of setting the AVR 7200's output levels to an external source. Once this button is pressed, press the **▲/▼** on the **Navigation Button 14** to select the channel being adjusted, then press the **Set Button 16**, followed by the **▲/▼** on the **Navigation Button 14** again, to change the level setting. (See page 33 for more information.)
- 14 Navigation Button:** This single disc-like button is used to navigate through the on-screen configuration menus, to scroll through the options list and to select choices for the various settings such as delay, speakers, surround modes, digital inputs, etc. To use the button, simply press it left, right, up or down in the direction indicated by the **▲▼◀▶** icons printed on the button disc. Depending on the menu being used, pressing the button will either change the video highlight that indicates a specific choice or it will change the option shown in the on-screen or front panel display. The sections in this manual describing the unit's individual features and configuration options contain specific information on how the navigation controls are used.

- 15 Digital Select Button:** Press this button to assign one of the digital inputs **29 32 17 19** to a source. (See page 30 for more information on using digital inputs.)
- 16 Set Button:** This button is used to enter settings into the AVR 7200's memory. It is also used in the setup procedures for delay time, speaker configuration and channel output level adjustment.
- 17 Transport Play Buttons:** These buttons have no direct function on the AVR 7200, but they are used when the remote is programmed for a compatible DVD, CD or tape player. Pressing these buttons will transmit a forward- or reverse-play command, according to the capabilities of the player being controlled. In the factory default setting, these buttons are programmed for Harman Kardon DVD players so that you may control a compatible player without having to switch devices.
- 18 Volume Up/Down Buttons:** These controls share the common disc in the lower third of the remote. To raise the volume, press the button marked **▲** by pressing towards the top of the remote. To lower the volume, press the button marked **▼** by pressing towards the bottom of the remote. The **◀▶** buttons on the left and right sides of this disc change channels up or down when the TV, cable box or satellite **Input Selectors 4** have been pressed.
- 19 Transport Fast-Play/Scan Buttons:** These buttons have no direct function on the AVR 7200, but they are used when the remote is programmed for a compatible DVD, CD or tape player. Pressing these buttons will transmit a fast-play forward, fast-play reverse, or fast-forward or -reverse scan command, according to the capabilities of the player being controlled. In the factory default setting, these buttons are preprogrammed with the remote codes for Harman Kardon DVD players so that you may control a compatible player without having to switch devices.
- 20 Main Transport Controls:** These buttons have no direct function on the AVR 7200, but they are used when the remote is programmed for a compatible DVD, CD or tape player. Pressing these buttons will transmit a stop (■), record (●), or pause (⏸) command, according to the capabilities of the player being controlled. In the factory default setting, these buttons are programmed with the remote codes for Harman Kardon DVD players so that you may control a compatible player without having to switch devices.
- 21 Track Skip Up/Down Buttons:** These buttons do not have a direct function with the AVR 7200, but when used with a compatibly programmed CD or DVD changer will change the track or chapter currently being played. In the factory default setting, these buttons are programmed with the remote codes for Harman Kardon DVD players so that you may control a compatible player without having to switch devices.

MAIN REMOTE CONTROL FUNCTIONS

22 Preset Up/Down Button: When the tuner is in use, press this button to scroll through the stations programmed into the AVR 7200's memory.

23 Tuning Up/Down Button: When the tuner is in use, this button will tune up or down through the selected frequency band. If the **Tuning Mode Button 12 16** has been pressed so that **AUTO** appears in the **Lower Display Line B** and the **AUTO Indicator J** lights, pressing either button will cause the tuner to seek the next station with acceptable signal strength for quality reception. When **MANUAL** appears in the **Lower Display Line B** and the **AUTO Indicator J** goes out, pressing this button will tune stations in single-step increments. (See page 32 for more information.)

24 Disc Skip Button: This button has no direct function for the AVR 7200 but may be used to change the disc in a CD or DVD changer when the remote is programmed for that type of device.

25 Program Button: This button is used to begin the process of programming the remote. Press and hold this button for three seconds to place the remote in the programming mode. Once the red LED under the **Set Button 16** lights, release the button. You may then select from the desired option. (See pages 38 – 47 for more information on configuring the remote.)

26 Light Button: Press this button to activate the remote's backlight for ease of use in darkened rooms.

27 Multiroom: Press this button to activate the multiroom system or to begin the process of changing the input or volume level for the second zone. (See page 36 for more information on the multiroom system.)

28 Macro Buttons: Press these buttons to store or recall a "Macro", which is a preprogrammed sequence of commands stored in the remote. (See page 41 for more information on macros.)

29 Sleep Button: Press this button to place the unit in the Sleep mode. After the time shown in the display, the AVR 7200 will automatically go into the Standby mode. Each press of the button changes the time until turn-off in the following order:

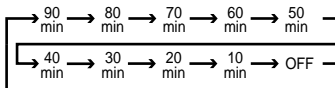

30 Night Mode Button: Press this button to activate the Night mode. This mode is available in specially encoded Dolby Digital sources, and it preserves dialogue (center channel) intelligibility at low volume levels.

31 OSD Button: Press this button to activate the On-Screen Display (OSD) system used to set up or adjust the AVR 7200's parameters.

32 Mute Button: Press this button to momentarily silence the AVR 7200 or TV set being controlled, depending on which device has been selected.

33 AM/FM Tuner Select: Press this button to select the AVR 7200's tuner as the listening choice. Pressing this button when the tuner is already in use will select between the AM and FM bands.

34 Channel Up/Down Selector: This button has no function when the AVR is being controlled, but when programmed for use with a VCR, TV, cable box, satellite receiver or other similar product it will change the channel up or down. See pages 38 – 47 for more information on programming the remote.

35 Delay Select Button: Press this button to begin the process for setting the delay times used by the AVR 7200 when processing surround sound. After pressing this button, the delay times are entered by pressing the **Set Button 16** and then the **▲/▼ Navigation Button 14** to change the setting. Press the **Set Button 16** again to complete the process. (See page 23 for more information on setting delay times.)

36 Speaker Select Button: Press this button to begin the process of configuring the AVR 7200's bass management system. Then press the **▲/▼ Navigation Button 14** to select the channel you wish to set up. Press the **Set Button 16** and then select another channel to configure. When all adjustments have been completed, press the **Set Button 16** twice to exit the settings and return to normal operation. (See page 21 for more information on speaker setup.)

37 Memory Button: Press this button to enter a radio station into the AVR 7200's preset memory. Once **PRESET MEMORY** flashes in the **Lower Display Line B** and the **Memory Indicator G** lights, you have five seconds to enter a preset memory location using the **Numeric Keys 11**. (See page 32 for more information.)

38 Stereo Mode Select Button: Press this button to select a stereo listening mode. The first press of the button places the AVR 7200 in a true, two-channel, left/right Stereo mode with no surround processing. The next press selects either five-channel Stereo or seven-channel Stereo, depending on the speaker configuration.

39 DTS Neo:6 Mode Select Button: Press this button to select a DTS Neo:6 mode. (See page 29 for the available DTS Neo:6 options.)

40 DTS Digital Mode Select Button: When a DTS-encoded digital source is playing, each press of this button will scroll through the available DTS modes. The specific choice of modes will vary according to the type of encoding on the disc and your system's

speaker configuration. When a DTS source is not in use, this button has no function. (See page 29 for the available DTS digital options.)

41 Dolby Mode Select Button: This button is used to select from the available Dolby Surround modes. Each press of this button will select one of the Dolby Pro Logic II modes or Dolby 3 Stereo. When a Dolby Digital-encoded source is in use, the Dolby Digital mode may also be selected. (See page 29 for the available Dolby surround mode options.)

42 6-Channel/8-Channel Input Select: Press this button to select the device connected to the **6- or 8-Channel Direct Inputs 34**. (See page 28 for more information.)

43 SPL Select Button: This button activates the EzSet function to quickly and accurately calibrate the AVR 7200's output levels. When the button is pressed you will then need to select between automatic EzSet operation or using the remote as a manual SPL meter by pressing the **▲/▼ Navigation Button 14** until your choice appears in the remote's LCD display. Press the **Set Button 16** to enter the setting, and then follow the instructions as displayed in the LCD display. (For complete information, see page 24.)

44 EzSet Microphone Sensor: The microphone sensor that is used by the EzSet system is behind the three slots at the top of the remote control. When using EzSet to calibrate the AVR 7200 be certain that the slots are not covered. (See page 24 for more information on using EzSet.)

45 Lens: The infrared emitters behind the plastic lens at the top of the remote communicate the remote codes to the AVR 7200. Be certain that the lens is not covered when using the remote, and point the lens toward the AVR for best results. In learning mode, the remote receives IR codes to be learned through a sensor behind the lens.

NOTE: DO NOT remove the rubber plug that is supplied to cover the jack on the upper right side of the remote. The jack is not active and is reserved for future use.

INSTALLATION AND CONNECTIONS

System Installation

After unpacking the unit, locating it in a place with adequate ventilation and placing it on a solid surface capable of supporting its weight, you will need to make the connections to your audio and video equipment.

IMPORTANT NOTE: For your personal safety and to avoid possible damage to your equipment and speakers, it is always good practice to turn off and unplug the AVR and ALL source equipment from the AC output before making any audio or video system connections.

Audio Equipment Connections

We recommend that you use high-quality interconnect cables when making connections to source equipment and recorders to preserve the integrity of the signals.

1. Connect the analog output of a CD player to the **CD Audio Inputs 31**.

NOTE: When the CD player has both fixed and variable audio outputs, it is best to use the fixed output unless you find that the input to the receiver is so low that the sound is noisy, or so high that it is distorted.

2. Connect the analog Play/Out jacks of a cassette deck, MD, CD-R or other audio recorder to the **Tape Input Jacks 28**. Connect the analog Record/In jacks on the recorder to the **Tape Output Jacks 30** on the AVR 7200.
3. Connect the output of any digital sources such as such as a CD or DVD changer or player, advanced video game, a digital satellite receiver, HDTV tuner or digital cable set-top box or the output of a compatible computer sound card to the **Optical and Coaxial Digital Audio Inputs 29/32 17/19**.
4. Connect the coaxial or optical **Digital Audio Outputs 25/27** on the rear panel of the AVR to the matching digital input connections on a CD-R or MiniDisc recorder.
5. Assemble the AM loop antenna supplied with the unit so that the tabs at the bottom of the antenna loop snap into the holes in the base. Connect it to the **AM and GND Screw Terminals 10**.

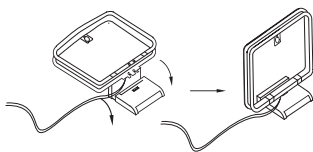

6. Connect the supplied FM antenna to the **FM (75-ohm) Connection 8**. The FM antenna may be an external roof antenna, an inside powered or wire-lead antenna or a connection from a cable TV system. If the antenna or connection uses 300-ohm

twin-lead cable, you must use an optional 300- to 75-ohm adapter to make the connection.

7. Connect the front, center, surround and surround back speaker outputs **1 3 2 2** to the respective speakers. If only one speaker is used for the surround back channel, it may be connected to either the **SBL** or **SBR Terminal 1**.

To ensure that all the audio signals are carried to your speakers without loss of clarity or resolution, we suggest that you use high-quality speaker cable. Many brands of cable are available and the choice of cable may be influenced by the distance between your speakers and the receiver, the type of speakers you use, personal preferences and other factors.

Regardless of the brand of cable selected, we recommend that you use a cable constructed of multistrand copper with a gauge of 14 or smaller. Remember that in specifying cable, the lower the number, the thicker the cable.

Cable with a gauge of 16 may be used for runs of less than ten feet. We do not recommend that you use cables with an AWG of 18 or higher, due to the power loss and degradation in performance that may occur.

Cables that are run inside walls should be marked to indicate listing with UL, CSA or other appropriate testing agency standards. Questions about running cables inside walls should be referred to an installer or a licensed electrician who is familiar with the NEC and/or the applicable local building codes in your area.

When connecting wires to the speakers, be certain to observe proper polarity. Note that the positive (+) terminal of each speaker connection has a specific color code as noted on page 8. However, most speakers still use a red terminal for the positive (+) connection. Connect the "negative" wire to the black terminal on both the receiver and the speaker.

NOTE: While most speaker manufacturers adhere to an industry convention of using black terminals for negative and red ones for positive, some may vary from this configuration. To ensure proper phase and optimal performance, consult the identification plate on your speaker or the speaker's manual to verify polarity. If you do not know the polarity of your speaker, ask your dealer for advice before proceeding, or consult the speaker's manufacturer.

We also recommend that the length of cable used to connect speaker pairs be identical. For example, use the same length piece of cable to connect the front-left and front-right or surround-left and surround-right speakers, even if the speakers are a different distance from the AVR 7200.

8. Connections to a subwoofer are normally made via a line-level audio connection from the **Subwoofer Output 14** to the line-level input of a powered subwoofer. When a passive subwoofer is used, the connection first goes to a power amplifier, which will be connected to one or more subwoofer speakers. If you are using a powered subwoofer that does not have line-level input connections, follow the instructions furnished with the speaker for connection information.

9. If an external multichannel audio source with 5.1 outputs such as an external digital processor/decoder, DVD-Audio or SACD player is used, connect the outputs of that device to the **8-Channel Direct Inputs 34**.

Video Equipment Connections

Video equipment is connected in the same manner as audio components. Again, the use of high-quality interconnect cables is recommended to preserve signal quality.

Although the outputs from any compatible video device may be connected to any video input, to simplify programming device codes into the remote control, we recommend that a hard-drive recorder product such as a TiVo® or ReplayTV® be connected to the **Video 1 Connectors 11 33**. If there is no hard-drive recorder in your system, connect the VCR to those connectors; otherwise connect it to the **Video 2 Connectors 4 9**. The audio outputs of your TV should be connected to the **Video 2 Inputs 9**, and the outputs of a cable box or satellite receiver to the **Video 3 Inputs 2**.

Note that the AVR 7200 will not convert signals from composite to S-Video, or vice versa. S-Video inputs may only be viewed when the AVR 7200 is connected to a TV set or video display with S-Video capability. If you use both standard composite video and S-Video sources in your system, it is important that you connect both an S-Video cable and a standard composite video cable (a coax cable with an RCA plug on both ends) between the AVR 7200 and your TV or projector. Consult the instructions for your TV set or projector for more information on connecting both types of signals.

1. Connect a VCR's or other video source's audio and video Play/Out jacks to the **Video 1/Video 2 Input Jacks 9 33** on the rear panel. The Audio and Video Record/In jacks on the VCR should be connected to the **Video 1/Video 2 Output Jacks 4 11** on the AVR 7200.
2. Connect the analog audio and video outputs of a satellite receiver, cable TV converter or television set or any other video source to the **Video 3 Input Jacks 2**.

INSTALLATION AND CONNECTIONS

3. Connect the analog audio and video outputs of a DVD or laser disc player to the **DVD Inputs 12**.
4. Connect the digital audio outputs of a DVD player, satellite receiver, cable box or HDTV converter to the appropriate **Optical or Coaxial Digital Inputs 29 32 17 19**.
5. Connect the **Video Monitor Output 23** jacks on the receiver to the composite or S-Video input of your television monitor or video projector.
6. If your DVD player and monitor both have component video connections, connect the component outputs of the DVD player to the **DVD Component Video Inputs 15**. Even when component video connections are used, the audio connections should still be made to either the analog **DVD Audio Inputs 1** or any of the **Optical or Coaxial Digital Input Jacks 29 32**.
7. If another device with component video outputs is available, connect it to the **Video 2 Component Video Inputs 16**. The audio connections for this device should be made to either the **Video 2 Inputs 9** or any of the **Optical or Coaxial Digital Input Jacks 17 19 29 32**.
8. If the component video inputs are used, connect the **Component Video Monitor Outputs 17** to the component video inputs of your TV, projector or display device.
9. If you have a camcorder, video game or other audio/video device that is connected to the AVR on a temporary, rather than permanent, basis, connect the audio, video and digital audio outputs of that device to the **Front-Panel Inputs 17 19 20**. A device connected here is selected as the Video 4 input, and the digital inputs must be assigned to the Video 4 input. (See page 19 for more information on input configuration.)

Video Connection Notes:

- When the component video jacks are used, the on-screen menus are not visible and you must switch to the standard composite or S-Video input on your TV to view them.
- The AVR 7200 will accept either standard composite, S-Video or Y/Pr/Pb component video signals. However, it will not convert composite or S signals to component video.
- Component or composite video signals may only be viewed in their native formats.

System and Power Connections

The AVR 7200 is designed for flexible use with multi-room systems, external control components and power amplifiers.

Main Room Remote Control Extension

If the receiver is placed behind a solid or smoked glass cabinet door, the obstruction may prevent the remote sensor from receiving commands. In this event, an optional remote sensor may be used. Connect the output of the remote sensor to the **Remote IR Input 6** jack.

If other components are also prevented from receiving remote commands, only one sensor is needed. Simply use this unit's sensor or a remote eye by running a connection from the **Remote IR Output 5** jack to the Remote IR Input jack on Harman Kardon or other compatible equipment.

Multiroom IR Link

The remote room IR receiver should be connected to the AVR 7200 via standard coaxial cable. Plug the IR connection cable into the **Multiroom IR Input 7** jack on the AVR 7200's rear panel.

If other Harman Kardon compatible source equipment is part of the main room installation, the **Remote IR Output 5** jack on the rear panel should be connected to the IR IN jack on source equipment. This will enable the remote room location to control source equipment functions.

NOTE: All remotely controlled components must be linked together in a "daisy chain": Connect the **IR OUT** jack of one unit to the **IR IN** of the next to establish this chain.

Multiroom Connections

The AVR 7200 is equipped with multizone capabilities that allow it to send a separate audio source to the remote zone from the one selected for use in the main room.

Depending on your system's requirement, three options are available for audio connection:

Option 1: Use high-quality, shielded audio interconnect cable from the AVR 7200's location to the remote room. In the remote room, connect the interconnect cable to a stereo power amplifier. The amplifier will be connected to the room's speakers. At the AVR 7200, plug the audio interconnect cables into the **Multiroom Audio Output 25** jacks on the AVR 7200's rear panel.

Option 2: Connect the **Multiroom Audio Output 25** jacks on the AVR 7200 to the inputs of an optional stereo power amplifier. Run high-quality speaker wire from the amplifier to the speakers in the remote room.

Option 3: Taking advantage of the AVR 7200's built-in seven-channel amplifier, it is possible to use two of the amplifier channels to power speakers in the remote room. When using this option you will not be able to use the full 7.1-channel capabilities of the AVR 7200

in the main listening room, but you will be able to add another listening room without additional external power amplifiers. To use the internal amplifiers to power a remote zone, connect the speakers for the remote room location to the **Surround Back/Multiroom Speaker Outputs 1**. Before using the remote room, you will need to configure the amplifiers for surround operation by changing a setting in the Advanced Select menu, following the instructions shown on page 34.

NOTE: For all options, you may connect an optional IR sensor in the remote room to the AVR 7200 via an appropriate cable. Connect the sensor's cable to the **Multiroom IR Input 7** on the AVR 7200 and use the Zone II remote to control the room volume. Alternatively, you may install an optional volume control between the output of the amplifiers and the speakers.

A-BUS Installation Connections

The AVR 7200 is among the very few receivers available today that offers built-in A-BUS Ready® operation. When used with an optional A-BUS keypad or control module, you have all the benefits of remote zone operation without the need for an external power amplifier.

To use the AVR 7200 with an approved A-BUS product, simply connect the keypad or module that is in the remote room to the AVR 7200 using standard "Category 5" wiring that is properly rated for the in-wall use specific to the installation. Terminate the wiring at the receiver end to a standard RJ-45 jack in compliance with the instructions furnished with the A-BUS module.

No further installation or adjustment is needed, as the A-BUS connector on the AVR 7200 routes the signals in and out of the keypad to their proper destination for power, signal source and control. The output fed to the A-BUS jack is determined by the AVR 7200's multi-room system, and the menus may be used as is.

RS-232 Connections

The AVR 7200 features an RS-232 serial port connection that may be used to control the unit via optional compatible, external keypads or control systems. The physical connection to the AVR 7200 from the control device is a standard D-9 connection, but to ensure compatible and proper operation, specific software commands and pin wiring schemes are required. Due to the complexity of RS-232 connections, they must be made only by trained installers familiar with their use. To obtain additional information on the use of the AVR 7200 with RS-232 control, please contact Harman Kardon's customer service department or consult our Web site at www.harmankardon.com.

INSTALLATION AND CONNECTIONS

AC Power Connections

This unit is equipped with three accessory AC outlets. They may be used to power accessory devices, but they should not be used with high-current draw equipment such as power amplifiers. The total power draw to each outlet may not exceed 100 watts.

The **Switched AC Accessory Outlets 20** will receive power only when the unit is on. This is recommended for devices that have no power switch or a mechanical power switch that may be left in the "ON" position.

NOTE: Many audio and video products go into a Standby mode when they are used with switched outlets, and cannot be fully turned on using the outlet alone without a remote control command.

The **Unswitched AC Accessory Outlet 19** will receive power as long as the unit is plugged into a powered AC outlet.

The AVR 7200 features a removable power cord that allows wires to be run to a complex installation so that the unit itself need not be installed until it is ready for connection. When all connections described above have been made, connect the AC Power cord to the **AC Power Cord Jack 18**.

The AVR 7200 draws significantly more current than other household devices such as computers that use removable power cords. For that reason, it is important that only the cord supplied with the unit (or a direct replacement of identical capacity) be used.

Once the power cord is connected, you are almost ready to enjoy the AVR 7200's incredible power and fidelity!

TROUBLESHOOTING GUIDE

SYMPTOM	CAUSE	SOLUTION
Unit does not function when Main Power Switch is pushed	<ul style="list-style-type: none"> No AC Power 	<ul style="list-style-type: none"> Make certain AC power cord is plugged into a live outlet Check to see whether outlet is switch-controlled
Display lights, but no sound or picture	<ul style="list-style-type: none"> Intermittent input connections Mute is on Volume control is down 	<ul style="list-style-type: none"> Make certain that all input and speaker connections are secure Press Mute Button 32 Turn up volume control
Unit turns on, but front panel display does not light up	<ul style="list-style-type: none"> Display brightness is turned off 	<ul style="list-style-type: none"> Follow the instructions in the Display Brightness section on page 34 so that the display is set to VFD FULL
No sound from any speaker; light around power switch is red	<ul style="list-style-type: none"> Amplifier is in protection mode due to possible short Amplifier is in protection mode due to internal problems 	<ul style="list-style-type: none"> Check speaker wire connections for shorts at receiver and speaker ends Contact your local Harman Kardon service center
No sound from surround or center speakers	<ul style="list-style-type: none"> Incorrect surround mode Input is monaural Incorrect configuration Stereo or Mono program material 	<ul style="list-style-type: none"> Select a mode other than Stereo There is no surround information from mono sources Check speaker mode configuration The surround decoder may not create center- or rear-channel information from nonencoded programs
Unit does not respond to remote commands	<ul style="list-style-type: none"> Weak batteries in remote Wrong device selected Remote sensor is obscured 	<ul style="list-style-type: none"> Change remote batteries Press the AVR selector Make certain front panel sensor is visible to remote or connect remote sensor
Intermittent buzzing in tuner	<ul style="list-style-type: none"> Local interference 	<ul style="list-style-type: none"> Move unit or antenna away from computers, fluorescent lights, motors or other electrical appliances
Letters flash in the channel indicator display and digital audio stops	<ul style="list-style-type: none"> Digital audio feed paused 	<ul style="list-style-type: none"> Resume play for DVD Check that Digital Input is selected

Processor Reset

In the rare case where the unit's operation or the displays seem abnormal, the cause may involve the erratic operation of the system's memory or microprocessor.

To correct this problem, first unplug the unit from the AC wall outlet and wait at least three minutes. After the pause, reconnect the AC power cord and check the unit's operation. If the system still malfunctions, a system reset may clear the problem.

To clear the AVR 7200's entire system memory including tuner presets, output level settings, delay times and speaker configuration data, first put the unit in Standby by pressing the **System Power Control**

Button 2. Next, press and hold the **Surround Mode Group Selector 7** and the **Tuner Mode Selector 16** buttons for three seconds.

The unit will turn on automatically and display the **RESET** message in the **Main Information Display 29**.

NOTE: Resetting the processor will erase any configuration settings you have made for speakers, output levels, surround modes, digital input assignments as well as the tuner presets. After a reset the unit will be returned to the factory presets, and all settings for these items must be reentered.

If the system is still operating incorrectly, there may have been an electronic discharge or severe AC line interference that has corrupted the memory or microprocessor.

If these steps do not solve the problem, consult an authorized Harman Kardon service center.

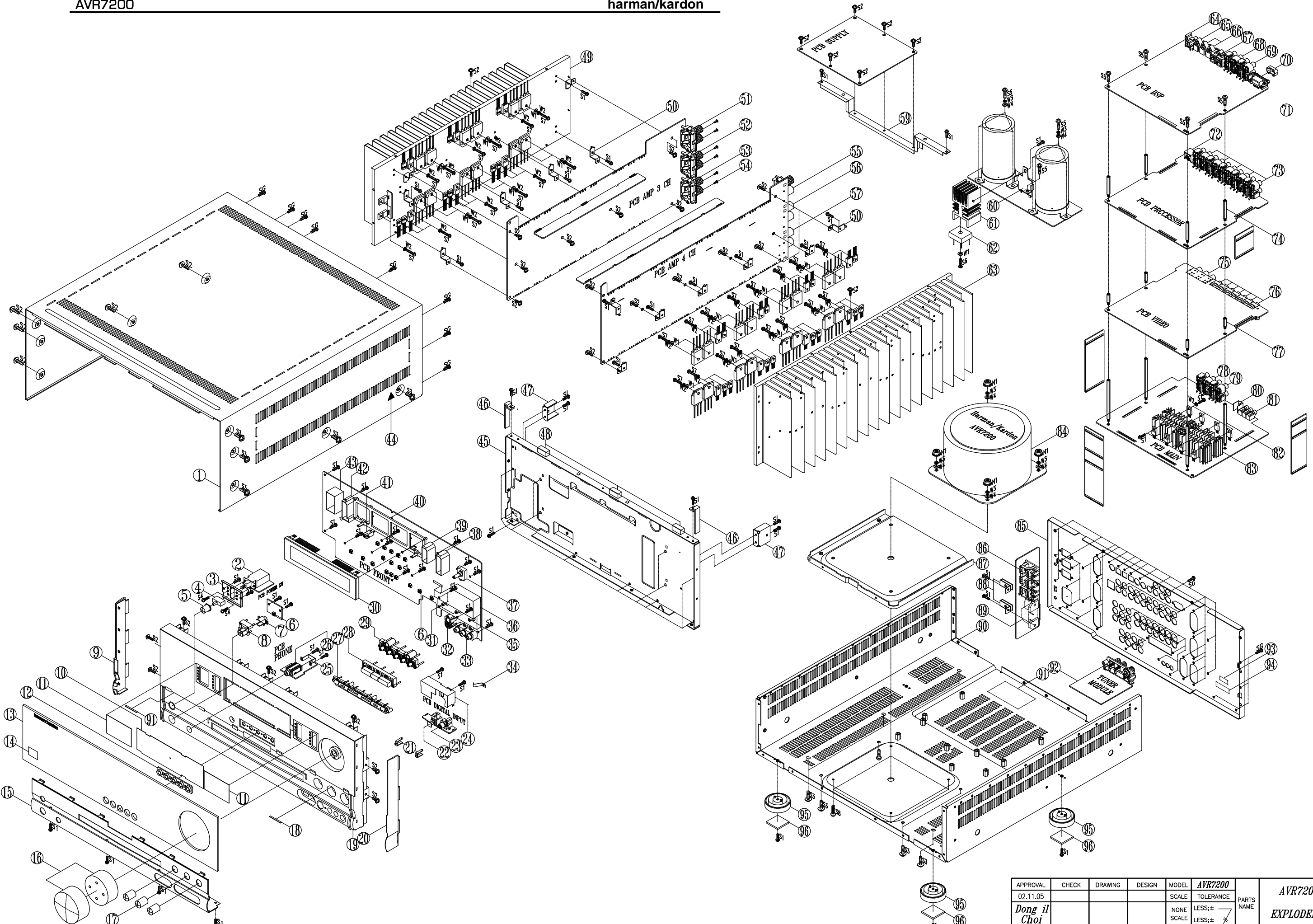

APPROVAL	CHECK	DRAWING	DESIGN	MODEL	AVR7200	PARTS NAME	AVR7200 US
02.11.05				SCALE	NONE		EXPLODED VIEW
				TOLERANCE	LESS;±		
				UNIT	LESS;±		
				m/m	LESS;±	TOCOM NO.	55706120

Dong Il Choi

AVR7200 EXPLODED VIEW PART LIST

Ref#	Part#	Qty		Description
1	55230660	1	PC	AC PUN COVER TOP AVR8000 METAL --
2	55231290	1	PC	SWIPUSH POWER SWITCH J46208000004 8.0A 250.0V 100MIOHM 1T 2P
3	55230510	1	PC	AC PUN BRACKET SW POWER AVR8000 --
4	55230340	1	PC	AC MLD HOLDER GUIDE POWER SW AVR800
5	55177810	1	PC	AC DEC BUTTON POWER HIPS DVD10 --
6	55145270	1	PC	SWITACT VERTICAL TACTILE F/B 50MIOA 12.0V 500MIOHM 1T 1P
7	55178020	1	PC	AC MLD BUTTON INDICATOR STAND-BY AVR520 --
8	55177820	1	PC	AC DEC BUTTON STANDBY --
9	55230280	1	PC	AC DEC ENDCAP LEFT HIPS AVR8000
10	55177800	1	PC	AC DEC CRYSTAL FILTER DISPLAY
11	55177990	2	PC	AC DIFFUSER 0.2T 59.6*41 WH NON-METAL
12	55273160	1	PC	AC DEC GUIDE BUTTON 5KEY --
13	55577220	1	PC	AC DEC CRYSTAL WINDOW DISPLAY AVR7200
14	55178620	1	PC	AC PRI LABEL "PLEASE" AVR520
15	55577160	1	PC	AC CPL CABINET AL PANEL AVR7200
16	55230470	1	PC	AC DEC KNOB MAIN HIPS AVR8000
17	55177750	3	PC	AC DEC KNOB TONE HIPS
18	55597950	2	PC	AC PUN PLATE SPACE AVR7500
19	55262200	1	PC	AC DEC CABINET PANEL FRONT AVR7500
20	55230320	1	PC	AC DEC ENDCAP RIGHT HIPS AVR8000
21	55178030	2	PC	AC MLD BUTTON INDICATOR VIDEO 4 AVR520 --
22	55125430	1	PC	D-LEM TORX178B RD RND CL
23	55175950	1	PC	CON PHONO SCKT RCA 1P W/GND JE010003MN
24	55182550	1	PC	AC PUN SHIELD DIGITAL ET
25	55124350	1	PC	AC PUN BRACKET HEADPHONE RT2280/RT2250(PAV5007/5005) --
26	55050690	1	PC	CONN-PHJAC 6.35 ST HORZ CKX3-6.35-04 BK 0 0
27	55498780	1	PC	AC DEC BUTTON 7 KEY AVR7200/8200 --
28	55577360	1	PC	AC DEC BUTTON 3 KEY SET AVR7200 --
29	55577380	1	PC	AC DEC BUTTON 5 KEY SET AVR7200/8200 --
30	55142780	1	PC	DISPLAY HNA-15LL01
31	55179920	2	PC	PR-ROT 100K0 OHM NON-LINEAR RK14K12400BR 0 0
32	55113960	1	PC	CON DIN SCKT SOCKET CONNECTOR SVHS EST-S408J
33	55171510	1	PC	CON PHONO SCKT RCA-313P 3 PINS
34	55178960	1	PC	AC SPRING PLATE SPRING GND C5212 0.2T AVR520
35	55179910	1	PC	PR-ROT 100K0 OHM NON-LINEAR RK14K12400BQ 0 0
36	55177570	1	PC	AC PUN SHIELD FENCE TONE
37	55134900	1	PC	SWIROT EC16B24204A5 5V 500U0A 10T 3P 0 0
38	55178940	1	PC	AC MOLD REFRACTOR E WH PL
39	55191530	1	PC	AC PLASTIC MOLD REFRACTOR B WH
40	55178440	1	PC	AC MLD HOLDER FL-GUIDE HIPS 94HB AVR520
41	55155930	1	PC	IC-REMOTE RPM6938-RSIP-A3 RECEIVER 38KHZ
42	55177960	1	PC	AC DIFFUSER REFLECTOR C WH NON-METAL
43	55178930	1	PC	AC MOLD REFRACTOR F WH PL
44	55149150	1	PC	AC PRI LABEL RISK CDRW1211
45	55629550	1	PC	AC CPL CABINET CHASSIS FRONT AVR7200
46	55230560	2	PC	AC PUN BRACKET TOP AVR8000 --
47	55230570	2	PC	AC PUN BRACKET SIDE SECC1.0T AVR8000 --
48	55275930	3	PC	AC RAW SHIELD FORM GASKET 71TSN 10-8-33-00
49	55629460	1	PC	AC HEATSINK POWER 3CH AVR7200 -- METAL
50	55168710	15	PC	AC PUN BRACKET HEATSINK
51	55637170	1	PC	CONN-SPE SPEAKER TER'BOARD(2P) BK/WH D/N B30290117N FE 19MM
52	55637180	1	PC	CONN-SPE SPEAKER TER'BOARD(2P) BK/BU D/N B30290118N FE 19MM
53	55637190	1	PC	CONN-SPE SPEAKER TER'BOARD(2P) BK/BN D/N B30290119N FE 19MM
54				no need(only europe version)

55	55637150	1	PC	CONN-SPE SPEAKER TER'BOARD(2P) RD/BK D/N B30290111N FE 19MM
56	55637160	1	PC	CONN-SPE SPEAKER TER'BOARD(2P) GY/BK D/N B30290115N FE 19MM
57	55637210	1	PC	CONN-SPE SPEAKER TER'BOARD(4P) GN/BK/TAN/BK B30490163N FE 19MM
59	55577420	1	PC	AC PUN BRACKET SUPPLY --
60	55577410	1	PC	AC PUN BRACKET H/SINK BRIDGE --
61	55304050	1	PC	AC METAL HEATSINK BRIDGE 34.4*28.5*64H --
62	55170630	1	PC	D-BRDHC BP3504WF 35.0A
63	55577440	1	PC	AC HEATSINK POWER 4CH AVR8200
64	55246370	1	PC	CON PHONO SCKT RCA 1P W/GND JE010003LN OG
65	55125440	1	PC	D-LEM TOTX178B RD RND CL
66	55125430	2	PC	D-LEM TORX178B RD RND CL
67	55191600	1	PC	CON PHONO SCKT RCA 2P W/GNDCAP JW-1502SN OO
68	55191420	1	PC	CON PHONO SCKT RCA 4P JW-4104RSA
69	55191450	1	PC	CON PHONO SCKT RCA 4P JW-4104RSC
70	55554510	1	PC	CONN-SPE 87204-6063 WITH DUST COVER FE 2.77MM 9 -- 0 0
72	55426050	1	PC	JACK-TELE SNAP-IN GOLDEN TELECOM GDL1-8P8C
73	55176330	5	PC	CON PHONO SCKT RCA 4P JW4104RS GND
74	55231260	4	PC	SCREW-SPEC 6MM 34MM -- 53 0 0
75	55436080	1	PC	CON PHONO SCKT RCA 9P JW-4109RS RD,RD,RD,BU,BU,BU,GN,GN,GN
76	55149520	7	PC	CON DIN SCKT MIX SOCKET RCA-118JP1S
77	55577340	4	PC	SCREW-SPEC 6MM 15MM -- 53 0 0
78	55317140	1	PC	CON PHONO SCKT RCA 4P JW-4104RA GN,BN,PP,TA
79	55317130	1	PC	CON PHONO SCKT RCA 4P JW-4104RC WH,BU,RD,GA
80	55176420	1	PC	AC PUN BRACKET BKT GROUND ET 0.5T AVR520
81	55176390	3	PC	CON PHONO SCKT STEREO JACK JW350S
82	55577350	4	PC	SCREW-SPEC 6MM 75.1MM -- 53 0 0
83	55194550	4	PC	AC HEATSINK 60*20*50H AL6063S-T5 -- ME
84	55703440	1	PC	MAIN POWER X FORMER
85	55576870	1	PC	AC CPL REAR PANEL AVR7200
86	55231540	1	PC	CONN-SPE A206D0054P AC OUTLET US NA 15.25MM 3 BK 0 A0
87	55645660	1	PC	AC PUN BRACKET TRANS BOTTOM AVR7200/8200 --
88	55222020	2	PC	AC PUN BRACKET AC INLET
89	55222010	1	PC	CON MAINS INLET A/C INLET 7014-NGP
90	55177740	1	PC	AC DEC KNOB MAIN HIPS AVR8000
91	55576940	1	PC	AC PRI LABEL BARCODE AVR7200
92	55615050	1	PC	EPR TUNER MODULE
93	55174780	1	PC	AC PRI LABEL DATE
94	55576920	1	PC	AC PRI LABEL SERIAL AVR7200
95	55445360	4	PC	AC FOOT HIPS 94HB ROUND 15.8MM 50MM NOT DEFINED Y DIA
96	55174760	4	PC	AC FOOT RUBBER ROUND 3.0MM 25.0MM JIS 60 Y DIA

S1	55127070	65	PC	SCREW-ST 3MM 10MM JIS B 1122 19 0 0
S2	55127120	45	PC	SCREW-ST 3MM 8MM JIS B 1122 53 0 0
S3	55127090	20	PC	SCREW-ST 4MM 8MM JIS B 1122 25 0 0
S4	55164800	2	PC	SCREW 3MM 8MM DIN963 62 2182 B7
S5	55231250	11	PC	SCREW-ST 4MM 8MM D020400800 53 0 0
S6	55127290	1	PC	SCREW-ST 3MM 18MM
S7	55178320	63	PC	SCREW-ST 3MM 12MM JIS B 1122 53 0 A4
S8	55684180	4	PC	SCREW-SAM 4MM 12MM
SG	55135460	66	PC	SCREW-SPEC 3MM 10MM JIS 27 0 0
W1	55127300	63	PC	WASHER-SPR 3.1MM 6.2MM 0.8MM Y 53 0 I4
W2	55127310	28	PC	WASHER 3.3MM 8.0MM 0.5MM Y 53 0 A4
W3	55131550	4	PC	WASHER-SPR 4.2MM 7.2MM 1.0MM N/A 53 0 0
W4	55131730	4	PC	WASHER 4.8MM 12MM 1.0MM -- 53 0 I5

EXACT SCREW LOCATIONS

S1	55127070	3X10 B	AL PANEL	4	4
			FRONT PCB	16	20
			PHONE JACK	2	22
			STANDBY PCB	2	24
			BKT SHIELD DIGITAL	2	26
			POWER SW	2	28
			F/CH+MAIN CH	8	36
			F/CH+TRANS BTM	2	38
			F/CH+H/SINK	4	42
			BKT SIDE+F/CH	4	46
			BKT TOP+F/CH	2	48
			M/CH+FOOT	4	52
			BKT BRIDGE	1	53
			3CH BKT H/SINK	7	60
			4CH BKT H/SINK	8	68
			H/SINK TR (MAIN PCB)	8	8
			BKT AC INLET(SUPPLYPCB)	2	10
S2	55127120	W3X8 Y	F/PANEL+F/CH	7	7
			3CH AMP PCB	7	14
			4CH AMP PCB	8	22
			SUPPLY PCB	6	28
			POSISTER(3 CH 1, 4 CH 1)	2	30
S3	55127090	W4X8 B	TOP COVER	10	10
			M/CH+H/SINK	6	16
			M/CH+T/BTM	4	20
S4	55164800	BM3X8	POWER SW+BKT	2	2
S5	55231250	BM4X8	MAIN CONDENSOR	6	6
			BKT BRIDGE H/SINK	1	7
			DSP PCB	4	11
S6	55127290	3X18	BRIDGE DIODE+ H/SINK	1	1
S7	55178320	3X12	3CH H/SINK	27	27
			4CH H/SINK	36	63
			3CH H/SINK TR	2	65
S8	55684180	4X12	TRANS+NUT	4	4
SG	55135460	GROUND	3CH H/SINK	2	2
			4CH H/SINK	2	4
			MAIN	10	14
			AMP	14	28
			DSP	7	35
			PROCESSOR	5	40
			VIDEO	9	49
			TUNER	2	51
			MAIN	3	54
			OUTLET	2	56
			INLET	2	58
			TOP COVER	8	66
W1	55127300	SPRING 3	3CH AMP TR IC	27	27
			4CH AMP TR IC	36	63
			3 CH H/SINK TR	2	65
			MAIN PCB H/SINK	8	73
W2	55127310	WASHER 3	3CH AMP TR IC	12	12
			4CH AMP TR IC	16	28
			BRIDGE	1	29
W3	55131550	SPRING 4	TRANS	4	4
W4	55131730	WASHER 4	TRANS	4	4
N1	55309350	NUT		4	4

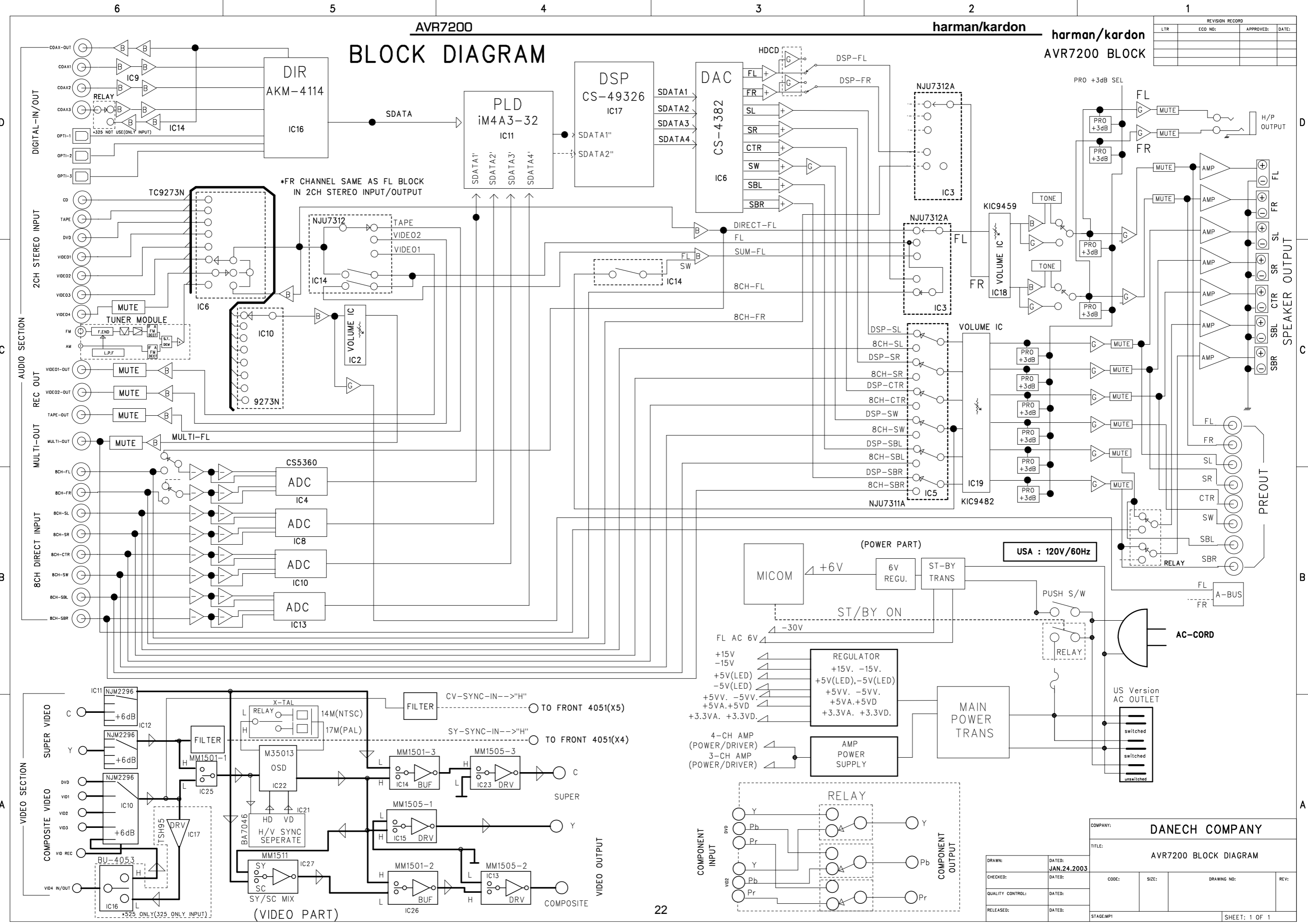

REVISION RECORD			
LTR	ECO NO:	APPROVED:	DATE:

DRAWN:		DATED: JAN.24.2003	
CHECKED:		DATED:	
QUALITY CONTROL:		DATED:	
RELEASED:		DATED:	
COMPANY: DANECH COMPANY			
TITLE: AVR7200 BLOCK DIAGRAM			
CODE:	SIZE:	DRAWING NO:	REV:
STAGE:MP1		SHEET: 1 OF 1	

AVR7200 OFFSET ADJUSTMENT & IDLE CURRENT ADJUSTMENT

DC Offset - Adjustment

Function : 8CH DIRECT INPUT

Volume level: minimum

Test position: Speaker out terminal (between "+" and "-") speaker jack

No Load

- a. Turn ON power
- b. Align to about $0\pm 5\text{mV}$

Channel	Check point	Adjustment location	Adjustment value
FRONT L CH	FL SPEAKER	VR11(3channel AMP)	$0\pm 10\text{mV}$
REAR L CH	SL SPEAKER	VR21(3channel AMP)	$0\pm 10\text{mV}$
SURRBACK L CH	SL SPEAKER	VR31(3channel AMP)	$0\pm 10\text{mV}$
REAR R CH	SR SPEAKER	VR41(4channel AMP)	$0\pm 10\text{mV}$
SURRBACK R CH	SBR SPEAKER	VR51(4channel AMP)	$0\pm 10\text{mV}$
FRONT R CH	FR SPEAKER	VR61(4channel AMP)	$0\pm 10\text{mV}$
CENTER CH	CTR SPEAKER	VR71(4channel AMP)	$0\pm 10\text{mV}$

- c. After 5 Min. Repeat at $0\pm 20\text{mV}$

Idle - adjustment

Function : 8 CH DIRECT INPUT

Volume level: minimum

- a. Turn ON power
- b. Align to about $12.0\sim 13.0\text{mV}$.

Channel	Check point	Adjustment location	Adjustment value
FRONT L CH	P101(R172)	VR12 (3channel AMP)	$12.0\text{mV}\sim 13.0\text{mV}$
REAR L CH	P201(R272)	VR22 (3channel AMP)	$12.0\text{mV}\sim 13.0\text{mV}$
SURRBACK L CH	P301(R372)	VR32 (3channel AMP)	$12.0\text{mV}\sim 13.0\text{mV}$
REAR R CH	P401(R472)	VR42 (4channel AMP)	$12.0\text{mV}\sim 13.0\text{mV}$
SURRBACK R CH	P501(R572)	VR52 (4channel AMP)	$12.0\text{mV}\sim 13.0\text{mV}$
FRONT R CH	P601(R672)	VR62 (4channel AMP)	$12.0\text{mV}\sim 13.0\text{mV}$
CENTER CH	P701(R772)	VR72 (4channel AMP)	$12.0\text{mV}\sim 13.0\text{mV}$

- c. After 5 Min. Repeat at **$12.0\text{mV}\sim 13.0\text{mV}$** .

harman/kardon

Service Bulletin

Service bulletin # H/K2003-04 June 2003

Warranty labor rate: MINOR repair

To: All harman/kardon Service Centers

Model: AVR7200

Subject: Noise

In the event you receive an AVR7200 with the complaint: “there is a “static”, snapping, or ticking sound periodically coming from one or more of the speakers”, follow the instructions below:

The amplifiers inside Harman/Kardon AVRs are capable of extremely high power. With seven channels of on-board amplification, there is potential for significant heat generation. Suggestions for the most efficient and reliable AVR operation include:

- 1) Cabinets: Keep an open space of at least of 2-3" to the sides and top of the receiver.
- 2) Do not block the ventilation holes in the top cover, as these are crucial.
- 3) Whenever possible, the AVR7200 should be the top component in the stack, or put on its own shelf.
- 4) If used in cabinet with a closed door, be sure to provide adequate ventilation between other components and the AVR7200 rear panel. In extreme cases an external fan may be required.

If the problem persists even with adequate ventilation, change resistors R162, R223, R252, R295 on the DSP board from 10.0Ω to 2.2Ω.

Procedure:

- 5) Remove the top cover (18 Phillips screws).
- 6) Locate 10.0Ω SMD resistors R162, R223, R252, R295 in the center of the DSP board at the top of the unit. Unsolder and replace each with 2.2Ω SMD resistor, h/k part# P2.2GCT-ND.
- 7) Replace the top cover and test the unit.

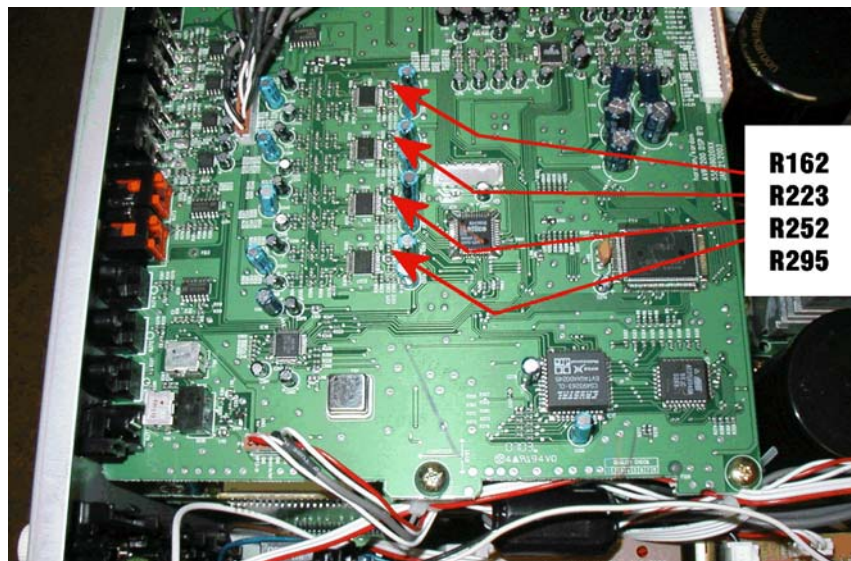

MODELS	SERIAL NUMBER	STATUS	ACTION
AVR7200	All Serial Numbers Affected	May Need Modification If Noise Present	Change R162, R223, R252, R295 from 10.0Ω to 2.2Ω

harman/kardon**TECH TIPS****Troubleshooting tips and solutions to common service problems**

For models:

TIP# HKTT2003-01 Rev5

AVR7000/7200/7300/8000	AVR10
AVR100/200/300/500	DPR1001
AVR110/210/310/510	DPR1005
AVR120/220/320/520	DPR2005
AVR125/225/325/525	HK3370/3470/3375/3475
AVR130/230/330/430/630	HK3250
AVR135/235/335/435/635	

Subject: Backup Memory on AVR/DPR/HK series receivers

In the event of the complaint: “the receiver is losing its memory (any programmed system settings) when the unit is turned off, or after the unit is unplugged (briefly*)”:

Check and replace:

Model	Designator	Location	Description	Part number
AVR10	C712 D709	Front PCB	0.047 Farad 5.5v capacitor and 1N4148 diode	#3439247315 #2058322101
AVR7000	C730	Front PCB	0.047 Farad 5.5v capacitor	# P10790-ND or # J3432147324X
AVR7200	C106	Front PCB	0.047 Farad 5.5v capacitor	# P10790-ND
AVR7300	C657	DSP PCB	0.047 Farad 5.5v capacitor	# H01-CEZXA0479MN-5
AVR8000	C726	Front PCB	0.047 Farad 5.5v capacitor	# 55230310NR or # P10790-ND
AVR100/200	C412	Front PCB	0.047 Farad 5.5v capacitor	# CEGT-B473J-0J0
AVR300	C906	Front PCB	0.1Farad 5.5v capacitor	# J4433210421X or # P10791-ND
AVR500	C906	Front PCB	0.1Farad 5.5v capacitor	# J4433210421X or # P10791-ND
AVR110/210/310/510 AVR120/220/320/520	C216	Front PCB	0.047 Farad 5.5v capacitor	# P10790-ND
AVR125/225	C734,C885	Front PCB	two 0.1F capacitors in parallel	# BCESOHD104
AVR325/525	C106	Front PCB	0.047 Farad 5.5v capacitor	# P10790-ND
AVR130/230/330	BAT1	Front PCB	3.6v Battery	# HABGP40BVH3A3H
AVR135/235/335	BAT1	Front PCB	3.6v Battery	# HGP15BNH3A3H
AVR430/630	C657	DSP PCB	0.047 Farad 5.5v capacitor	# CEZXA0479MN-5
AVR435/635	C557	DSP PCB	0.047 Farad 5.5v capacitor	# H03-CEZXA0479MN-0
DPR1001	BC601	Main PCB	0.1Farad 5.5v capacitor	# CEGT-B104J-0J0
DPR1005/2005	C437	Processor PCB	0.047 Farad 5.5v capacitor	# CEZXA0479MN-5
HK3370/3470	C301	Front PCB	0.1Farad 5.5v capacitor	# CEGT-B104J-0J0
HK3375/3475	C301	Front PCB	0.1Farad 5.5v capacitor	# CEGT-B104J-0J0
HK3250	C712 D709	Front PCB	0.047 Farad 5.5v capacitor and 1N4148 diode	#3439247315 #2058322101

* After approximately two weeks of being disconnected from AC supply, even a normally functioning receiver may lose any programmed settings and switch to default settings. (Four weeks for the DPR1005 & 2005)

AVR7200 Electrical Parts List

Ref Designator	Part Number	Qty		Description
Main PCB				
<i>Capacitors</i>				
C210	2041669071	1	PC	CPM 100N0F +20% 250.0V
C211	2041669071	1	PC	CPM 100N0F +20% 250.0V
C212	2041669071	1	PC	CPM 100N0F +20% 250.0V
C223	208519800	1	PC	CE 3MI3F +20% 50.0V 85C
C242	55126160NR	1	PC	CE 6MI8F +20% 16.0V 85C
C243	13039870AM	1	PC	CE 2MI2F +20% 16.0V 85C
C244	553153000	1	PC	CE 4MI7F +20% 35.0V 85C
C245	553153000	1	PC	CE 4MI7F +20% 35.0V 85C
C252	55232360NR	1	PC	CE 2MI2F +20% 100.0V 85C
C253	55232360NR	1	PC	CE 2MI2F +20% 100.0V 85C
C226	2028804091	1	PC	CCCFMIC 100N0F +80% -20% 16.0V Y5V
C229	2028804091	1	PC	CCCFMIC 100N0F +80% -20% 16.0V Y5V
C232	2028804091	1	PC	CCCFMIC 100N0F +80% -20% 16.0V Y5V
C235	2028804091	1	PC	CCCFMIC 100N0F +80% -20% 16.0V Y5V
C238	2028804091	1	PC	CCCFMIC 100N0F +80% -20% 16.0V Y5V
C241	2028804091	1	PC	CCCFMIC 100N0F +80% -20% 16.0V Y5V
C248	2028804091	1	PC	CCCFMIC 100N0F +80% -20% 16.0V Y5V
C251	2028804091	1	PC	CCCFMIC 100N0F +80% -20% 16.0V Y5V
C261	2050659091	1	PC	CCCFMIC 100P0F +5% -5% 50.0V NP0
C262	2050659091	1	PC	CCCFMIC 100P0F +5% -5% 50.0V NP0
C263	2050659091	1	PC	CCCFMIC 100P0F +5% -5% 50.0V NP0
C264	2050659091	1	PC	CCCFMIC 100P0F +5% -5% 50.0V NP0
C265	2050659091	1	PC	CCCFMIC 100P0F +5% -5% 50.0V NP0
C266	2050659091	1	PC	CCCFMIC 100P0F +5% -5% 50.0V NP0
C267	2050659091	1	PC	CCCFMIC 100P0F +5% -5% 50.0V NP0
C268	2050659091	1	PC	CCCFMIC 100P0F +5% -5% 50.0V NP0
C269	2050659091	1	PC	CCCFMIC 100P0F +5% -5% 50.0V NP0
C270	2050659091	1	PC	CCCFMIC 100P0F +5% -5% 50.0V NP0
C271	2050659091	1	PC	CCCFMIC 100P0F +5% -5% 50.0V NP0
C272	2050659091	1	PC	CCCFMIC 100P0F +5% -5% 50.0V NP0
C273	2050659091	1	PC	CCCFMIC 100P0F +5% -5% 50.0V NP0
C274	2050659091	1	PC	CCCFMIC 100P0F +5% -5% 50.0V NP0
C275	2050659091	1	PC	CCCFMIC 100P0F +5% -5% 50.0V NP0
C276	2050659091	1	PC	CCCFMIC 100P0F +5% -5% 50.0V NP0
C201	1036482071	1	PC	CPF 47N0F +10% 100.0V
C202	1036482071	1	PC	CPF 47N0F +10% 100.0V
C203	1036482071	1	PC	CPF 47N0F +10% 100.0V
C204	1036482071	1	PC	CPF 47N0F +10% 100.0V
C205	1036482071	1	PC	CPF 47N0F +10% 100.0V
C206	1036482071	1	PC	CPF 47N0F +10% 100.0V
C207	1036482071	1	PC	CPF 47N0F +10% 100.0V
C208	1036482071	1	PC	CPF 47N0F +10% 100.0V
C209	1036482071	1	PC	CPF 47N0F +10% 100.0V
C224	2026884030	1	PC	CE 1U0F +20% 50.0V 85C
C225	2026888030	1	PC	CE 10U0F +20% 50.0V 85C
C227	2026884030	1	PC	CE 1U0F +20% 50.0V 85C
C228	2026888030	1	PC	CE 10U0F +20% 50.0V 85C
C230	2026884030	1	PC	CE 1U0F +20% 50.0V 85C
C231	20269180AM	1	PC	CE 1MI0F +20% 6.3V 85C
C233	2026884030	1	PC	CE 1U0F +20% 50.0V 85C
C234	2026888030	1	PC	CE 10U0F +20% 50.0V 85C
C236	2026884030	1	PC	CE 1U0F +20% 50.0V 85C
C237	2026888030	1	PC	CE 10U0F +20% 50.0V 85C
C239	2026884030	1	PC	CE 1U0F +20% 50.0V 85C
C240	2026888030	1	PC	CE 10U0F +20% 50.0V 85C
C246	2026884030	1	PC	CE 1U0F +20% 50.0V 85C
C247	5521357030	1	PC	CE 220U0F +20% 25.0V 85C
C249	2026884030	1	PC	CE 1U0F +20% 50.0V 85C
C250	5521357030	1	PC	CE 220U0F +20% 25.0V 85C
C254	2026818030	1	PC	CE 330U0F +20% 16.0V 85C

Ref Designator	Part Number	Qty		Description
Main PCB				
<i>Semiconductors</i>				
D201	55125540NR	1	PC	D-BRDLC BU6-04F
D202	55179300NR	1	PC	D-BRDLC BRIDGE W2-04F FRONTIER
D203	55248910NR	1	PC	D-BRDLC BU4-04F
D204	55248910NR	1	PC	D-BRDLC BU4-04F
IC01	55505780MU	1	PC	IC-REGPOSFXD KIA7824API TO-220IS NORMAL
IC02	55505780MU	1	PC	IC-REGPOSFXD KIA7824API TO-220IS NORMAL
IC03	55123960MU	1	PC	IC-REGPOSFXD KIA7805API NORMAL
IC04	55125450MU	1	PC	IC-REGPOSFXD BA033T NORMAL
IC05	55123960MU	1	PC	IC-REGPOSFXD KIA7805API NORMAL
IC06	55123990MU	1	PC	IC-REGNEGFXD KIA7905PI NORMAL
IC07	20832440MU	1	PC	IC-REGPOSFXD KIA7815API NORMAL
IC08	55124020MU	1	PC	IC-REGNEGFXD KIA7915PI NORMAL
IC09	55207930KV	1	PC	PHOTCOUP PC-17T1
IC10	55207930KV	1	PC	PHOTCOUP PC-17T1
D205	2049651085	1	PC	D-SLP 1SS355 35.0V 225MI0A
D206	2049651085	1	PC	D-SLP 1SS355 35.0V 225MI0A
D207	2049651085	1	PC	D-SLP 1SS355 35.0V 225MI0A
D208	2049651085	1	PC	D-SLP 1SS355 35.0V 225MI0A
D209	2049651085	1	PC	D-SLP 1SS355 35.0V 225MI0A
D211	2049651085	1	PC	D-SLP 1SS355 35.0V 225MI0A
D212	2049651085	1	PC	D-SLP 1SS355 35.0V 225MI0A
D213	2049651085	1	PC	D-SLP 1SS355 35.0V 225MI0A
D214	2049651085	1	PC	D-SLP 1SS355 35.0V 225MI0A
Q201	5517922056	1	PC	TR-SLPSWA KRA107M P
Q202	5517922056	1	PC	TR-SLPSWA KRA107M P
<i>Resistors</i>				
R201	80442780NR	1	PC	RMOF 4R7 OHM +5% 2.0W
R202	80442780NR	1	PC	RMOF 4R7 OHM +5% 2.0W
R203	80442780NR	1	PC	RMOF 4R7 OHM +5% 2.0W
R204	80442780NR	1	PC	RMOF 4R7 OHM +5% 2.0W
R206	80442780NR	1	PC	RMOF 4R7 OHM +5% 2.0W
R207	80442780NR	1	PC	RMOF 4R7 OHM +5% 2.0W
R208	552288400	1	PC	RW 5R6 OHM +5% 3.0W 100PPM/C -100PPM/C
R209	552288400	1	PC	RW 5R6 OHM +5% 3.0W 100PPM/C -100PPM/C
R220	1013600091	1	PC	RMGCFMIC 8K2 OHM +5% 62MI5W
R221	1013512091	1	PC	RMGCFMIC 22K0 OHM +5% 62MI5W
R222	1013512091	1	PC	RMGCFMIC 22K0 OHM +5% 62MI5W
R231	1013474091	1	PC	RMGCFMIC 100R0 OHM +5% 62MI5W
R232	1013474091	1	PC	RMGCFMIC 100R0 OHM +5% 62MI5W
R233	1013474091	1	PC	RMGCFMIC 100R0 OHM +5% 62MI5W
R234	1013474091	1	PC	RMGCFMIC 100R0 OHM +5% 62MI5W
R235	1013474091	1	PC	RMGCFMIC 100R0 OHM +5% 62MI5W
R236	1013474091	1	PC	RMGCFMIC 100R0 OHM +5% 62MI5W
R237	1013474091	1	PC	RMGCFMIC 100R0 OHM +5% 62MI5W
R238	1013474091	1	PC	RMGCFMIC 100R0 OHM +5% 62MI5W
R240	1013592091	1	PC	RMGCFMIC 3K9 OHM +5% 62MI5W
R241	1013501091	1	PC	RMGCFMIC 10K0 OHM +5% 62MI5W
R242	1013522091	1	PC	RMGCFMIC 47K0 OHM +5% 62MI5W
R243	1013522091	1	PC	RMGCFMIC 47K0 OHM +5% 62MI5W
R244	1013465091	1	PC	RMGCFMIC 47R0 OHM +5% 62MI5W
R246	1013491091	1	PC	RMGCFMIC 470R0 OHM +5% 62MI5W
R247	1013485091	1	PC	RMGCFMIC 270R0 OHM +5% 62MI5W
R248	1013465091	1	PC	RMGCFMIC 47R0 OHM +5% 62MI5W
<i>Miscellaneous</i>				
	55127070	8	PC	SCREW-ST 3MM 10MM JIS B 1122 J5636140010X 19 0 0
	55127300	8	PC	WASHER-SPR 3.1MM 6.2MM 0.8MM Y 53 0 I4
F200	555052000	1	PC	FUSE 2.0 A 250.0 V 0 A1
F201	555052000	1	PC	FUSE 2.0 A 250.0 V 0 A1
F202	555052000	1	PC	FUSE 2.0 A 250.0 V 0 A1
F203	555052000	1	PC	FUSE 2.0 A 250.0 V 0 A1
F204	555052000	1	PC	FUSE 2.0 A 250.0 V 0 A1

Ref Designator	Part Number	Qty		Description
Main PCB				
F205	555052000	1	PC	FUSE 2.0 A 250.0 V 0 A1
F206	555052000	1	PC	FUSE 2.0 A 250.0 V 0 A1
F207	555052000	1	PC	FUSE 2.0 A 250.0 V 0 A1
G101	55135980NR	1	PC	TERMLUG GND
G202	55176300	1	PC	AC PUN BRACKET GROUND MECHA RTDVD1 --
HS51	55194550	1	PC	AC HEATSINK 60*20*50H AL6063S-T5 -- ME
HS52	55194550	1	PC	AC HEATSINK 60*20*50H AL6063S-T5 -- ME
HS53	55194550	1	PC	AC HEATSINK 60*20*50H AL6063S-T5 -- ME
HS54	55194550	1	PC	AC HEATSINK 60*20*50H AL6063S-T5 -- ME
N203	556868200	1	PC	WIRECONASY UNIQUE 3P 250MM UL1007 RIBBON 22 1
N204	556868200	1	PC	WIRECONASY UNIQUE 3P 250MM UL1007 RIBBON 22 1
N205	551641500	1	PC	WIRECONASY UNIQUE 4P 160MM UL1007 PVC 26 1
N209	551835800	1	PC	WIRECONASY UNIQUE 9P 150MM UL1007 PVC 26 1
NJ01	55317130	1	PC	CON PHONO SCKT RCA 4P JW-4104RC WH,BU,RD,GA
NJ02	55317140	1	PC	CON PHONO SCKT RCA 4P JW-4104RA GN,BN,PP,TA
NJ03	55176390	1	PC	CON PHONO SCKT STEREO JACK JW350S
NJ04	55176390	1	PC	CON PHONO SCKT STEREO JACK JW350S
NJ05	55176390	1	PC	CON PHONO SCKT STEREO JACK JW350S
P201	55146620	1	PC	CONN 2.5MM 7 MA ST NAT 0 0
P202	55146610	1	PC	CONN 2.5MM 6 MA ST NAT 0 0
P205	55174630	1	PC	CONN 2.0MM 19 MA ST NAT MOLEX 35336-1910 0 0
P208	55174630	1	PC	CONN 2.0MM 19 MA ST NAT MOLEX 35336-1910 0 0
P210	55124800	1	PC	CONN 1.25MM 15 FE ST BK 00-8370-151-000-800 2794 A6
P211	55124960	1	PC	CONN 2.0MM 11 MA ST NAT MOLEX 35336-1110 0 0
FRONT PCB				
<i>Capacitors</i>				
C106	551343600	1	PC	CM 47MIOF +80% -20% 5.5V 70C
C136	1036482071	1	PC	CPF 47N0F +10% 100.0V
C141	1500213030	1	PC	CE 10U0F +20% 16.0V 85C
C314	55179410NR	1	PC	CPM 82N0F +5% 100.0V
C315	55179410NR	1	PC	CPM 82N0F +5% 100.0V
C100	1013842091	1	PC	CCCFMIC 820P0F +10% -10% 50.0V X7R
C101	1013842091	1	PC	CCCFMIC 820P0F +10% -10% 50.0V X7R
C102	2028804091	1	PC	CCCFMIC 100N0F +80% -20% 16.0V Y5V
C105	2028804091	1	PC	CCCFMIC 100N0F +80% -20% 16.0V Y5V
C109	2028804091	1	PC	CCCFMIC 100N0F +80% -20% 16.0V Y5V
C111	2050659091	1	PC	CCCFMIC 100P0F +5% -5% 50.0V NP0
C112	2050659091	1	PC	CCCFMIC 100P0F +5% -5% 50.0V NP0
C113	2050659091	1	PC	CCCFMIC 100P0F +5% -5% 50.0V NP0
C115	2050659091	1	PC	CCCFMIC 100P0F +5% -5% 50.0V NP0
C116	2050659091	1	PC	CCCFMIC 100P0F +5% -5% 50.0V NP0
C117	2028804091	1	PC	CCCFMIC 100N0F +80% -20% 16.0V Y5V
C118	2028804091	1	PC	CCCFMIC 100N0F +80% -20% 16.0V Y5V
C120	2050659091	1	PC	CCCFMIC 100P0F +5% -5% 50.0V NP0
C121	2050659091	1	PC	CCCFMIC 100P0F +5% -5% 50.0V NP0
C122	2050659091	1	PC	CCCFMIC 100P0F +5% -5% 50.0V NP0
C123	2050659091	1	PC	CCCFMIC 100P0F +5% -5% 50.0V NP0
C124	2050659091	1	PC	CCCFMIC 100P0F +5% -5% 50.0V NP0
C125	2050659091	1	PC	CCCFMIC 100P0F +5% -5% 50.0V NP0
C126	2050659091	1	PC	CCCFMIC 100P0F +5% -5% 50.0V NP0
C127	2050659091	1	PC	CCCFMIC 100P0F +5% -5% 50.0V NP0
C128	2050659091	1	PC	CCCFMIC 100P0F +5% -5% 50.0V NP0
C129	2028804091	1	PC	CCCFMIC 100N0F +80% -20% 16.0V Y5V
C130	2028804091	1	PC	CCCFMIC 100N0F +80% -20% 16.0V Y5V
C139	2028804091	1	PC	CCCFMIC 100N0F +80% -20% 16.0V Y5V
C140	2028804091	1	PC	CCCFMIC 100N0F +80% -20% 16.0V Y5V
C144	2028804091	1	PC	CCCFMIC 100N0F +80% -20% 16.0V Y5V
C220	1013879091	1	PC	CCCFMIC 22N0F +80% -20% 50.0V Y5V
C221	1013879091	1	PC	CCCFMIC 22N0F +80% -20% 50.0V Y5V
C103	2026783030	1	PC	CE 47U0F +20% 16.0V 85C 20251640
C104	2026901030	1	PC	CE 47U0F +20% 50.0V 85C
C107	2026888030	1	PC	CE 10U0F +20% 50.0V 85C
C108	2026895030	1	PC	CE 100N0F +20% 50.0V 85C
C110	2026901030	1	PC	CE 47U0F +20% 50.0V 85C

Ref Designator	Part Number	Qty		Description
FRONT PCB				
C119	2026888030	1	PC	CE 10U0F +20% 50.0V 85C
C131	2026783030	1	PC	CE 47U0F +20% 16.0V 85C 20251640
C132	2026783030	1	PC	CE 47U0F +20% 16.0V 85C 20251640
C133	2026783030	1	PC	CE 47U0F +20% 16.0V 85C 20251640
C134	2026783030	1	PC	CE 47U0F +20% 16.0V 85C 20251640
C135	1036482071	1	PC	CPF 47N0F +10% 100.0V
C137	2026783030	1	PC	CE 47U0F +20% 16.0V 85C 20251640
C138	2026783030	1	PC	CE 47U0F +20% 16.0V 85C 20251640
C142	1500213030	1	PC	CE 10U0F +20% 16.0V 85C
C143	2026888030	1	PC	CE 10U0F +20% 50.0V 85C
C300	1500213030	1	PC	CE 10U0F +20% 16.0V 85C
C301	1500213030	1	PC	CE 10U0F +20% 16.0V 85C
C302	3093623071	1	PC	CC 100P0F +5% -5% 50.0V NP0
C303	3093623071	1	PC	CC 100P0F +5% -5% 50.0V NP0
C304	8043459071	1	PC	CC 22P0F +5% -5% 50.0V NP0
C305	8043459071	1	PC	CC 22P0F +5% -5% 50.0V NP0
C306	1500213030	1	PC	CE 10U0F +20% 16.0V 85C
C307	1500213030	1	PC	CE 10U0F +20% 16.0V 85C
C308	2026783030	1	PC	CE 47U0F +20% 16.0V 85C 20251640
C309	2026783030	1	PC	CE 47U0F +20% 16.0V 85C 20251640
C310	1500213030	1	PC	CE 10U0F +20% 16.0V 85C
C311	1500213030	1	PC	CE 10U0F +20% 16.0V 85C
C312	5517937071	1	PC	CPM 18N0F +5% 100.0V
C313	5517937071	1	PC	CPM 18N0F +5% 100.0V
C316	5517939071	1	PC	CPM 3N3F +5% 100.0V
C317	5517939071	1	PC	CPM 3N3F +5% 100.0V
C318	5517937071	1	PC	CPM 18N0F +5% 100.0V
C319	5517937071	1	PC	CPM 18N0F +5% 100.0V
<i>Semiconductors</i>				
D107	55179310NR	1	PC	D-LEM RED/GREEN 3PIE RD RND CL
D108	20525530NR	1	PC	D-SR 1N4003 200.0V 1A
D109	55179310NR	1	PC	D-LEM RED/GREEN 3PIE RD RND CL
D120	20525530NR	1	PC	D-SR 1N4003 200.0V 1A
D700	55199400NR	1	PC	D-LEM CT-3SGTA GN RND 3.0 CL 60M0CD
D701	55199400NR	1	PC	D-LEM CT-3SGTA GN RND 3.0 CL 60M0CD
D702	55199400NR	1	PC	D-LEM CT-3SGTA GN RND 3.0 CL 60M0CD
D703	55199400NR	1	PC	D-LEM CT-3SGTA GN RND 3.0 CL 60M0CD
D704	55199400NR	1	PC	D-LEM CT-3SGTA GN RND 3.0 CL 60M0CD
D705	55199400NR	1	PC	D-LEM CT-3SGTA GN RND 3.0 CL 60M0CD
D706	55199400NR	1	PC	D-LEM CT-3SGTA GN RND 3.0 CL 60M0CD
D707	55199400NR	1	PC	D-LEM CT-3SGTA GN RND 3.0 CL 60M0CD
D708	55199400NR	1	PC	D-LEM CT-3SGTA GN RND 3.0 CL 60M0CD
D709	55199400NR	1	PC	D-LEM CT-3SGTA GN RND 3.0 CL 60M0CD
D710	55199400NR	1	PC	D-LEM CT-3SGTA GN RND 3.0 CL 60M0CD
D711	55199400NR	1	PC	D-LEM CT-3SGTA GN RND 3.0 CL 60M0CD
D712	55199400NR	1	PC	D-LEM CT-3SGTA GN RND 3.0 CL 60M0CD
D713	55199400NR	1	PC	D-LEM CT-3SGTA GN RND 3.0 CL 60M0CD
D714	55199400NR	1	PC	D-LEM CT-3SGTA GN RND 3.0 CL 60M0CD
D715	55199400NR	1	PC	D-LEM CT-3SGTA GN RND 3.0 CL 60M0CD
D716	55199400NR	1	PC	D-LEM CT-3SGTA GN RND 3.0 CL 60M0CD
D717	55199400NR	1	PC	D-LEM CT-3SGTA GN RND 3.0 CL 60M0CD
D718	55199400NR	1	PC	D-LEM CT-3SGTA GN RND 3.0 CL 60M0CD
D719	55199400NR	1	PC	D-LEM CT-3SGTA GN RND 3.0 CL 60M0CD
D720	55199400NR	1	PC	D-LEM CT-3SGTA GN RND 3.0 CL 60M0CD
D721	55199400NR	1	PC	D-LEM CT-3SGTA GN RND 3.0 CL 60M0CD
D722	55199400NR	1	PC	D-LEM CT-3SGTA GN RND 3.0 CL 60M0CD
D723	55199400NR	1	PC	D-LEM CT-3SGTA GN RND 3.0 CL 60M0CD
D724	55199400NR	1	PC	D-LEM CT-3SGTA GN RND 3.0 CL 60M0CD
D725	55199400NR	1	PC	D-LEM CT-3SGTA GN RND 3.0 CL 60M0CD
D726	55199400NR	1	PC	D-LEM CT-3SGTA GN RND 3.0 CL 60M0CD
D727	55199400NR	1	PC	D-LEM CT-3SGTA GN RND 3.0 CL 60M0CD
D728	55199400NR	1	PC	D-LEM CT-3SGTA GN RND 3.0 CL 60M0CD
D730	55199400NR	1	PC	D-LEM CT-3SGTA GN RND 3.0 CL 60M0CD
D731	55199400NR	1	PC	D-LEM CT-3SGTA GN RND 3.0 CL 60M0CD
D732	55199400NR	1	PC	D-LEM CT-3SGTA GN RND 3.0 CL 60M0CD

Ref Designator	Part Number	Qty		Description
FRONT PCB				
D733	55199400NR	1	PC	D-LEM CT-3SGTA GN RND 3.0 CL 60M0CD
D734	55199400NR	1	PC	D-LEM CT-3SGTA GN RND 3.0 CL 60M0CD
D735	55199400NR	1	PC	D-LEM CT-3SGTA GN RND 3.0 CL 60M0CD
D736	55199400NR	1	PC	D-LEM CT-3SGTA GN RND 3.0 CL 60M0CD
D737	55199400NR	1	PC	D-LEM CT-3SGTA GN RND 3.0 CL 60M0CD
D738	55199400NR	1	PC	D-LEM CT-3SGTA GN RND 3.0 CL 60M0CD
D739	55199400NR	1	PC	D-LEM CT-3SGTA GN RND 3.0 CL 60M0CD
D740	55199400NR	1	PC	D-LEM CT-3SGTA GN RND 3.0 CL 60M0CD
D741	55199400NR	1	PC	D-LEM CT-3SGTA GN RND 3.0 CL 60M0CD
D742	55199400NR	1	PC	D-LEM CT-3SGTA GN RND 3.0 CL 60M0CD
D743	55199400NR	1	PC	D-LEM CT-3SGTA GN RND 3.0 CL 60M0CD
D744	55199400NR	1	PC	D-LEM CT-3SGTA GN RND 3.0 CL 60M0CD
D745	55199400NR	1	PC	D-LEM CT-3SGTA GN RND 3.0 CL 60M0CD
D746	55199400NR	1	PC	D-LEM CT-3SGTA GN RND 3.0 CL 60M0CD
D747	55199400NR	1	PC	D-LEM CT-3SGTA GN RND 3.0 CL 60M0CD
D748	55199400NR	1	PC	D-LEM CT-3SGTA GN RND 3.0 CL 60M0CD
D749	55199400NR	1	PC	D-LEM CT-3SGTA GN RND 3.0 CL 60M0CD
D750	55199400NR	1	PC	D-LEM CT-3SGTA GN RND 3.0 CL 60M0CD
D751	55199400NR	1	PC	D-LEM CT-3SGTA GN RND 3.0 CL 60M0CD
D752	55199400NR	1	PC	D-LEM CT-3SGTA GN RND 3.0 CL 60M0CD
D753	55199400NR	1	PC	D-LEM CT-3SGTA GN RND 3.0 CL 60M0CD
D800	55179330NR	1	PC	D-LEM RED/GREEN 5 RD RND CL
D100	2049651085	1	PC	D-SLP 1SS355 35.0V 225MI0A
D101	2049651085	1	PC	D-SLP 1SS355 35.0V 225MI0A
D102	2049651085	1	PC	D-SLP 1SS355 35.0V 225MI0A
D103	2049651085	1	PC	D-SLP 1SS355 35.0V 225MI0A
D104	2049651085	1	PC	D-SLP 1SS355 35.0V 225MI0A
D105	2049651085	1	PC	D-SLP 1SS355 35.0V 225MI0A
D106	2049651085	1	PC	D-SLP 1SS355 35.0V 225MI0A
D112	2049651085	1	PC	D-SLP 1SS355 35.0V 225MI0A
D113	2049651085	1	PC	D-SLP 1SS355 35.0V 225MI0A
D114	2049651085	1	PC	D-SLP 1SS355 35.0V 225MI0A
D115	2049651085	1	PC	D-SLP 1SS355 35.0V 225MI0A
D116	2049651085	1	PC	D-SLP 1SS355 35.0V 225MI0A
D117	2049651085	1	PC	D-SLP 1SS355 35.0V 225MI0A
D119	2049651085	1	PC	D-SLP 1SS355 35.0V 225MI0A
IC10	55690010MS	1	PC	IC-MICROCONT CXP82860-386Q MAIN AVR7200
IC11	20718660MT	1	PC	IC-LOGIC BU4094BF SHIFT REGISTER CMOS
IC12	20718660MT	1	PC	IC-LOGIC BU4094BF SHIFT REGISTER CMOS
IC13	20718660MT	1	PC	IC-LOGIC BU4094BF SHIFT REGISTER CMOS
IC14	20718660MT	1	PC	IC-LOGIC BU4094BF SHIFT REGISTER CMOS
IC15	55087180MT	1	PC	IC-LOGIC BU4051BCF MULTIPLEXER HCT
IC30	55142610MT	1	PC	IC-OPERAMP NJM2068M DUAL OP
IC16	55179630NR	1	PC	PHOTCOUP PC-17T1 PHOTOCOUPLER DIP4
Q102	5513318092	1	PC	TR-SSD DTC114YKA N 10K0 OHM 47K0 OHM
Q103	5513318092	1	PC	TR-SSD DTC114YKA N 10K0 OHM 47K0 OHM
Q104	5513318092	1	PC	TR-SSD DTC114YKA N 10K0 OHM 47K0 OHM
Q105	5513318092	1	PC	TR-SSD DTC114YKA N 10K0 OHM 47K0 OHM
Q106	5513318092	1	PC	TR-SSD DTC114YKA N 10K0 OHM 47K0 OHM
Q107	5513318092	1	PC	TR-SSD DTC114YKA N 10K0 OHM 47K0 OHM
Q108	5513318092	1	PC	TR-SSD DTC114YKA N 10K0 OHM 47K0 OHM
Q109	5513318092	1	PC	TR-SSD DTC114YKA N 10K0 OHM 47K0 OHM
Q110	5513318092	1	PC	TR-SSD DTC114YKA N 10K0 OHM 47K0 OHM
Q111	5513318092	1	PC	TR-SSD DTC114YKA N 10K0 OHM 47K0 OHM
Q112	5513318092	1	PC	TR-SSD DTC114YKA N 10K0 OHM 47K0 OHM
Q113	5513318092	1	PC	TR-SSD DTC114YKA N 10K0 OHM 47K0 OHM
Q114	5513318092	1	PC	TR-SSD DTC114YKA N 10K0 OHM 47K0 OHM
Q115	5513318092	1	PC	TR-SSD DTC114YKA N 10K0 OHM 47K0 OHM
Q700	5513333092	1	PC	TR-SSD DTC114TKA N 10K0 OHM
Q701	5513333092	1	PC	TR-SSD DTC114TKA N 10K0 OHM
Q702	5513333092	1	PC	TR-SSD DTC114TKA N 10K0 OHM
Q703	5513333092	1	PC	TR-SSD DTC114TKA N 10K0 OHM
Q704	5513333092	1	PC	TR-SSD DTC114TKA N 10K0 OHM
Q705	5513333092	1	PC	TR-SSD DTC114TKA N 10K0 OHM
Q706	5513333092	1	PC	TR-SSD DTC114TKA N 10K0 OHM
Q707	5513333092	1	PC	TR-SSD DTC114TKA N 10K0 OHM
Q708	5513333092	1	PC	TR-SSD DTC114TKA N 10K0 OHM

Ref Designator	Part Number	Qty		Description
FRONT PCB				
Q709	5513333092	1	PC	TR-SSD DTC114TKA N 10K0 OHM
Q710	5513333092	1	PC	TR-SSD DTC114TKA N 10K0 OHM
Q711	5513333092	1	PC	TR-SSD DTC114TKA N 10K0 OHM
Q712	5513333092	1	PC	TR-SSD DTC114TKA N 10K0 OHM
Q713	5513333092	1	PC	TR-SSD DTC114TKA N 10K0 OHM
Q714	5513333092	1	PC	TR-SSD DTC114TKA N 10K0 OHM
Q715	5513333092	1	PC	TR-SSD DTC114TKA N 10K0 OHM
Q716	5513333092	1	PC	TR-SSD DTC114TKA N 10K0 OHM
Q717	5513333092	1	PC	TR-SSD DTC114TKA N 10K0 OHM
Q718	5513333092	1	PC	TR-SSD DTC114TKA N 10K0 OHM
Q719	5513333092	1	PC	TR-SSD DTC114TKA N 10K0 OHM
Q720	5513333092	1	PC	TR-SSD DTC114TKA N 10K0 OHM
Q721	5513333092	1	PC	TR-SSD DTC114TKA N 10K0 OHM
Q722	5513333092	1	PC	TR-SSD DTC114TKA N 10K0 OHM
Q800	5513318092	1	PC	TR-SSD DTC114YKA N 10K0 OHM 47K0 OHM
Q100	5514267056	1	PC	TR-SLPLF MPSA06 N 500MIOA
Q101	5513335056	1	PC	TR-SLPLF MPSA56 Y P -500MIOA -300V
Q116	5517922056	1	PC	TR-SLPSWA KRA107M P
RM10	55155930MU	1	PC	IC-REMOTE RPM6938-RSIP-A3 RECEIVER 38KHZ
<i>Resistors</i>				
R100	1013529091	1	PC	RMGCFMIC 68K0 OHM +5% 62MI5W
R101	1013529091	1	PC	RMGCFMIC 68K0 OHM +5% 62MI5W
R102	1013594091	1	PC	RMGCFMIC 4K7 OHM +5% 62MI5W
R103	1013441091	1	PC	RMGCFMIC 10R0 OHM +5% 62MI5W
R104	1013522091	1	PC	RMGCFMIC 47K0 OHM +5% 62MI5W
R105	1013534091	1	PC	RMGCFMIC 100K0 OHM +5% 62MI5W
R106	1013600091	1	PC	RMGCFMIC 8K2 OHM +5% 62MI5W
R108	1013501091	1	PC	RMGCFMIC 10K0 OHM +5% 62MI5W
R109	1013483091	1	PC	RMGCFMIC 220R0 OHM +5% 62MI5W
R110	1013577091	1	PC	RMGCFMIC 1K0 OHM +5% 62MI5W
R111	1013491091	1	PC	RMGCFMIC 470R0 OHM +5% 62MI5W
R112	1013491091	1	PC	RMGCFMIC 470R0 OHM +5% 62MI5W
R113	1013489091	1	PC	RMGCFMIC 390R0 OHM +5% 62MI5W
R114	1013489091	1	PC	RMGCFMIC 390R0 OHM +5% 62MI5W
R115	1013491091	1	PC	RMGCFMIC 470R0 OHM +5% 62MI5W
R116	1013491091	1	PC	RMGCFMIC 470R0 OHM +5% 62MI5W
R117	1013489091	1	PC	RMGCFMIC 390R0 OHM +5% 62MI5W
R118	1013489091	1	PC	RMGCFMIC 390R0 OHM +5% 62MI5W
R119	1013501091	1	PC	RMGCFMIC 10K0 OHM +5% 62MI5W
R120	1013501091	1	PC	RMGCFMIC 10K0 OHM +5% 62MI5W
R121	1013501091	1	PC	RMGCFMIC 10K0 OHM +5% 62MI5W
R122	1013501091	1	PC	RMGCFMIC 10K0 OHM +5% 62MI5W
R123	1013594091	1	PC	RMGCFMIC 4K7 OHM +5% 62MI5W
R124	1013594091	1	PC	RMGCFMIC 4K7 OHM +5% 62MI5W
R126	1013577091	1	PC	RMGCFMIC 1K0 OHM +5% 62MI5W
R127	1013577091	1	PC	RMGCFMIC 1K0 OHM +5% 62MI5W
R128	1013577091	1	PC	RMGCFMIC 1K0 OHM +5% 62MI5W
R129	1013577091	1	PC	RMGCFMIC 1K0 OHM +5% 62MI5W
R130	1013577091	1	PC	RMGCFMIC 1K0 OHM +5% 62MI5W
R131	1013594091	1	PC	RMGCFMIC 4K7 OHM +5% 62MI5W
R132	1013594091	1	PC	RMGCFMIC 4K7 OHM +5% 62MI5W
R133	1013577091	1	PC	RMGCFMIC 1K0 OHM +5% 62MI5W
R134	1013577091	1	PC	RMGCFMIC 1K0 OHM +5% 62MI5W
R135	1013594091	1	PC	RMGCFMIC 4K7 OHM +5% 62MI5W
R136	1013501091	1	PC	RMGCFMIC 10K0 OHM +5% 62MI5W
R137	1013594091	1	PC	RMGCFMIC 4K7 OHM +5% 62MI5W
R140	1013577091	1	PC	RMGCFMIC 1K0 OHM +5% 62MI5W
R141	1013577091	1	PC	RMGCFMIC 1K0 OHM +5% 62MI5W
R142	1013577091	1	PC	RMGCFMIC 1K0 OHM +5% 62MI5W
R145	1013577091	1	PC	RMGCFMIC 1K0 OHM +5% 62MI5W
R146	1013474091	1	PC	RMGCFMIC 100R0 OHM +5% 62MI5W
R147	1013577091	1	PC	RMGCFMIC 1K0 OHM +5% 62MI5W
R148	1013577091	1	PC	RMGCFMIC 1K0 OHM +5% 62MI5W
R149	1013577091	1	PC	RMGCFMIC 1K0 OHM +5% 62MI5W
R150	1013577091	1	PC	RMGCFMIC 1K0 OHM +5% 62MI5W

Ref Designator	Part Number	Qty		Description
FRONT PCB				
R151	1013474091	1	PC	RMGCFMIC 100R0 OHM +5% 62MI5W
R152	1013577091	1	PC	RMGCFMIC 1K0 OHM +5% 62MI5W
R153	1013577091	1	PC	RMGCFMIC 1K0 OHM +5% 62MI5W
R154	1013577091	1	PC	RMGCFMIC 1K0 OHM +5% 62MI5W
R155	1013577091	1	PC	RMGCFMIC 1K0 OHM +5% 62MI5W
R156	1013474091	1	PC	RMGCFMIC 100R0 OHM +5% 62MI5W
R157	1013577091	1	PC	RMGCFMIC 1K0 OHM +5% 62MI5W
R158	1013577091	1	PC	RMGCFMIC 1K0 OHM +5% 62MI5W
R159	1013577091	1	PC	RMGCFMIC 1K0 OHM +5% 62MI5W
R160	1013577091	1	PC	RMGCFMIC 1K0 OHM +5% 62MI5W
R161	1013474091	1	PC	RMGCFMIC 100R0 OHM +5% 62MI5W
R162	1013577091	1	PC	RMGCFMIC 1K0 OHM +5% 62MI5W
R163	1013577091	1	PC	RMGCFMIC 1K0 OHM +5% 62MI5W
R164	1013577091	1	PC	RMGCFMIC 1K0 OHM +5% 62MI5W
R165	1013501091	1	PC	RMGCFMIC 10K0 OHM +5% 62MI5W
R166	1013501091	1	PC	RMGCFMIC 10K0 OHM +5% 62MI5W
R167	1013501091	1	PC	RMGCFMIC 10K0 OHM +5% 62MI5W
R168	1013501091	1	PC	RMGCFMIC 10K0 OHM +5% 62MI5W
R169	1013474091	1	PC	RMGCFMIC 100R0 OHM +5% 62MI5W
R170	1032875091	1	PC	RMGCFMIC 0 OHM +0% 62MI5W
R171	1032875091	1	PC	RMGCFMIC 0 OHM +0% 62MI5W
R173	1013501091	1	PC	RMGCFMIC 10K0 OHM +5% 62MI5W
R174	1013501091	1	PC	RMGCFMIC 10K0 OHM +5% 62MI5W
R175	1013491091	1	PC	RMGCFMIC 470R0 OHM +5% 62MI5W
R176	1013522091	1	PC	RMGCFMIC 47K0 OHM +5% 62MI5W
R177	1013592091	1	PC	RMGCFMIC 3K9 OHM +5% 62MI5W
R178	1013522091	1	PC	RMGCFMIC 47K0 OHM +5% 62MI5W
R201	1013577091	1	PC	RMGCFMIC 1K0 OHM +5% 62MI5W
R202	1013579091	1	PC	RMGCFMIC 1K2 OHM +5% 62MI5W
R203	1013582091	1	PC	RMGCFMIC 1K5 OHM +5% 62MI5W
R204	1013586091	1	PC	RMGCFMIC 2K2 OHM +5% 62MI5W
R205	1013588091	1	PC	RMGCFMIC 2K7 OHM +5% 62MI5W
R206	1013590091	1	PC	RMGCFMIC 3K3 OHM +5% 62MI5W
R207	1013596091	1	PC	RMGCFMIC 5K6 OHM +5% 62MI5W
R208	1013600091	1	PC	RMGCFMIC 8K2 OHM +5% 62MI5W
R209	1013508091	1	PC	RMGCFMIC 18K0 OHM +5% 62MI5W
R211	1013577091	1	PC	RMGCFMIC 1K0 OHM +5% 62MI5W
R212	1013579091	1	PC	RMGCFMIC 1K2 OHM +5% 62MI5W
R213	1013582091	1	PC	RMGCFMIC 1K5 OHM +5% 62MI5W
R214	1013586091	1	PC	RMGCFMIC 2K2 OHM +5% 62MI5W
R215	1013588091	1	PC	RMGCFMIC 2K7 OHM +5% 62MI5W
R216	1013590091	1	PC	RMGCFMIC 3K3 OHM +5% 62MI5W
R217	1013596091	1	PC	RMGCFMIC 5K6 OHM +5% 62MI5W
R218	1013600091	1	PC	RMGCFMIC 8K2 OHM +5% 62MI5W
R219	1013508091	1	PC	RMGCFMIC 18K0 OHM +5% 62MI5W
R220	1013501091	1	PC	RMGCFMIC 10K0 OHM +5% 62MI5W
R221	1013501091	1	PC	RMGCFMIC 10K0 OHM +5% 62MI5W
R302	1013577091	1	PC	RMGCFMIC 1K0 OHM +5% 62MI5W
R303	1013577091	1	PC	RMGCFMIC 1K0 OHM +5% 62MI5W
R304	1013534091	1	PC	RMGCFMIC 100K0 OHM +5% 62MI5W
R305	1013534091	1	PC	RMGCFMIC 100K0 OHM +5% 62MI5W
R306	1013562091	1	PC	RMGCFMIC 1M0 OHM +10% 62MI5W
R307	1013562091	1	PC	RMGCFMIC 1M0 OHM +10% 62MI5W
R308	1013522091	1	PC	RMGCFMIC 47K0 OHM +5% 62MI5W
R309	1013522091	1	PC	RMGCFMIC 47K0 OHM +5% 62MI5W
R310	1013483091	1	PC	RMGCFMIC 220R0 OHM +5% 62MI5W
R311	1013483091	1	PC	RMGCFMIC 220R0 OHM +5% 62MI5W
R312	1013491091	1	PC	RMGCFMIC 470R0 OHM +5% 62MI5W
R313	1013491091	1	PC	RMGCFMIC 470R0 OHM +5% 62MI5W
R314	1013534091	1	PC	RMGCFMIC 100K0 OHM +5% 62MI5W
R315	1013534091	1	PC	RMGCFMIC 100K0 OHM +5% 62MI5W
R316	1013512091	1	PC	RMGCFMIC 22K0 OHM +5% 62MI5W
R317	1013512091	1	PC	RMGCFMIC 22K0 OHM +5% 62MI5W
R318	1013592091	1	PC	RMGCFMIC 3K9 OHM +5% 62MI5W
R319	1013592091	1	PC	RMGCFMIC 3K9 OHM +5% 62MI5W
R320	1013586091	1	PC	RMGCFMIC 2K2 OHM +5% 62MI5W
R321	1013586091	1	PC	RMGCFMIC 2K2 OHM +5% 62MI5W

Ref Designator	Part Number	Qty		Description
FRONT PCB				
R322	1013495091	1	PC	RMGCFMIC 680R0 OHM +5% 62MI5W
R323	1013495091	1	PC	RMGCFMIC 680R0 OHM +5% 62MI5W
R700	1013465091	1	PC	RMGCFMIC 47R0 OHM +5% 62MI5W
R701	1013465091	1	PC	RMGCFMIC 47R0 OHM +5% 62MI5W
R702	1013465091	1	PC	RMGCFMIC 47R0 OHM +5% 62MI5W
R703	1013465091	1	PC	RMGCFMIC 47R0 OHM +5% 62MI5W
R704	1013465091	1	PC	RMGCFMIC 47R0 OHM +5% 62MI5W
R705	1013465091	1	PC	RMGCFMIC 47R0 OHM +5% 62MI5W
R706	1013478091	1	PC	RMGCFMIC 150R0 OHM +5% 62MI5W
R707	1013465091	1	PC	RMGCFMIC 47R0 OHM +5% 62MI5W
R709	1013465091	1	PC	RMGCFMIC 47R0 OHM +5% 62MI5W
R711	1013465091	1	PC	RMGCFMIC 47R0 OHM +5% 62MI5W
R713	1013465091	1	PC	RMGCFMIC 47R0 OHM +5% 62MI5W
R715	1013465091	1	PC	RMGCFMIC 47R0 OHM +5% 62MI5W
R717	1013465091	1	PC	RMGCFMIC 47R0 OHM +5% 62MI5W
R718	1013478091	1	PC	RMGCFMIC 150R0 OHM +5% 62MI5W
R720	1013465091	1	PC	RMGCFMIC 47R0 OHM +5% 62MI5W
R722	1013465091	1	PC	RMGCFMIC 47R0 OHM +5% 62MI5W
R724	1013478091	1	PC	RMGCFMIC 150R0 OHM +5% 62MI5W
R725	1013478091	1	PC	RMGCFMIC 150R0 OHM +5% 62MI5W
R726	1013478091	1	PC	RMGCFMIC 150R0 OHM +5% 62MI5W
R727	1013478091	1	PC	RMGCFMIC 150R0 OHM +5% 62MI5W
R728	1013478091	1	PC	RMGCFMIC 150R0 OHM +5% 62MI5W
R729	1013478091	1	PC	RMGCFMIC 150R0 OHM +5% 62MI5W
R730	1013478091	1	PC	RMGCFMIC 150R0 OHM +5% 62MI5W
R731	1013478091	1	PC	RMGCFMIC 150R0 OHM +5% 62MI5W
R732	1013478091	1	PC	RMGCFMIC 150R0 OHM +5% 62MI5W
R733	1013478091	1	PC	RMGCFMIC 150R0 OHM +5% 62MI5W
R734	1013478091	1	PC	RMGCFMIC 150R0 OHM +5% 62MI5W
R735	1013478091	1	PC	RMGCFMIC 150R0 OHM +5% 62MI5W
R736	1013478091	1	PC	RMGCFMIC 150R0 OHM +5% 62MI5W
R737	1013478091	1	PC	RMGCFMIC 150R0 OHM +5% 62MI5W
R738	1013478091	1	PC	RMGCFMIC 150R0 OHM +5% 62MI5W
R739	1013478091	1	PC	RMGCFMIC 150R0 OHM +5% 62MI5W
R740	1013478091	1	PC	RMGCFMIC 150R0 OHM +5% 62MI5W
R741	1013478091	1	PC	RMGCFMIC 150R0 OHM +5% 62MI5W
R742	1013478091	1	PC	RMGCFMIC 150R0 OHM +5% 62MI5W
R743	1013478091	1	PC	RMGCFMIC 150R0 OHM +5% 62MI5W
R744	1013478091	1	PC	RMGCFMIC 150R0 OHM +5% 62MI5W
R745	1013478091	1	PC	RMGCFMIC 150R0 OHM +5% 62MI5W
R746	1013478091	1	PC	RMGCFMIC 150R0 OHM +5% 62MI5W
R800	1013495091	1	PC	RMGCFMIC 680R0 OHM +5% 62MI5W
R801	1013495091	1	PC	RMGCFMIC 680R0 OHM +5% 62MI5W
R802	10134810	1	PC	RMGCFMIC 180R0 OHM +5% 62MI5W
R803	10134810	1	PC	RMGCFMIC 180R0 OHM +5% 62MI5W
RV10	55134900NR	1	PC	SWIROT EC16B24204A5 5V 500U0A 10T 3P 0 0
RV30	551799200	1	PC	PR-ROT 100K0 OHM NON-LINEAR RK14K12400BR 0 0
RV31	551799200	1	PC	PR-ROT 100K0 OHM NON-LINEAR RK14K12400BR 0 0
RV32	551799100	1	PC	PR-ROT 100K0 OHM NON-LINEAR RK14K12400BQ 0 0
J400	1032875091	1	PC	RMGCFMIC 0 OHM +0% 62MI5W
J401	1032875091	1	PC	RMGCFMIC 0 OHM +0% 62MI5W
J402	1032875091	1	PC	RMGCFMIC 0 OHM +0% 62MI5W
J404	1032875091	1	PC	RMGCFMIC 0 OHM +0% 62MI5W
<i>Miscellaneous</i>				
DP10	55142780NR	1	PC	DISPLAY HNA-15LL01
FN10	55177570	1	PC	AC PUN SHIELD FENCE TONE
L100	5517938016	1	PC	LF 4U7H +10% 1.7 OHM 190.0A
L101	5517938016	1	PC	LF 4U7H +10% 1.7 OHM 190.0A
L102	5516884016	1	PC	LF 47U0H +10% 5.8 OHM 70MI0A
N704	556864000	1	PC	WIRECONASY UNIQUE 10P 600MM UL1533 SHIELD 26 1
N706	551757900	1	PC	WIRECONASY UNIQUE 4P 100MM UL1007 PVC DISCRETE 26 1
N708	552128100	1	PC	WIRECONASY UNIQUE 9P 300MM UL1007 PVC DISCRETE 24
N709	557244600	1	PC	WIRECONASY UNIQUE 2P 150MM UL1007 PVC DISCRETE 26 1
N712	556862000	1	PC	WIRECONASY DL 2.0MM 10P 450MM UL1533 SHIELD 26 1
NJ80	55171510	1	PC	CON PHONO SCKT RCA-313P 3 PINS

Ref Designator	Part Number	Qty		Description
FRONT PCB				
NJ81	55113960	1	PC	CON DIN SCKT SOCKET CONNECTOR SVHS EST-S408J
P705	55090030	1	PC	CONN 2.0MM 4 MA R NAT LW2003P04 0 0
P710	55230490	1	PC	CONN 1.25MM 31 FE R BK 00-6216-031-120-808 0 0
P711	55124740	1	PC	CONN 1.25MM 15 FE R BK 00-8370-157-000-800 2794 A6
Y100	55126140NR	1	PC	CRESONATOR 10M0 HZ 25.0 OHM 0F
S200	55145270KX	1	PC	SWITACT VERTICAL TACTILE F/B 50MI0A 12.0V 500MIOOHM 1T 1P
S201	55145270KX	1	PC	SWITACT VERTICAL TACTILE F/B 50MI0A 12.0V 500MIOOHM 1T 1P
S202	55145270KX	1	PC	SWITACT VERTICAL TACTILE F/B 50MI0A 12.0V 500MIOOHM 1T 1P
S203	55145270KX	1	PC	SWITACT VERTICAL TACTILE F/B 50MI0A 12.0V 500MIOOHM 1T 1P
S204	55145270KX	1	PC	SWITACT VERTICAL TACTILE F/B 50MI0A 12.0V 500MIOOHM 1T 1P
S205	55145270KX	1	PC	SWITACT VERTICAL TACTILE F/B 50MI0A 12.0V 500MIOOHM 1T 1P
S206	55145270KX	1	PC	SWITACT VERTICAL TACTILE F/B 50MI0A 12.0V 500MIOOHM 1T 1P
S207	55145270KX	1	PC	SWITACT VERTICAL TACTILE F/B 50MI0A 12.0V 500MIOOHM 1T 1P
S208	55145270KX	1	PC	SWITACT VERTICAL TACTILE F/B 50MI0A 12.0V 500MIOOHM 1T 1P
S209	55145270KX	1	PC	SWITACT VERTICAL TACTILE F/B 50MI0A 12.0V 500MIOOHM 1T 1P
S211	55145270KX	1	PC	SWITACT VERTICAL TACTILE F/B 50MI0A 12.0V 500MIOOHM 1T 1P
S212	55145270KX	1	PC	SWITACT VERTICAL TACTILE F/B 50MI0A 12.0V 500MIOOHM 1T 1P
S213	55145270KX	1	PC	SWITACT VERTICAL TACTILE F/B 50MI0A 12.0V 500MIOOHM 1T 1P
S214	55145270KX	1	PC	SWITACT VERTICAL TACTILE F/B 50MI0A 12.0V 500MIOOHM 1T 1P
S215	55145270KX	1	PC	SWITACT VERTICAL TACTILE F/B 50MI0A 12.0V 500MIOOHM 1T 1P
S216	55145270KX	1	PC	SWITACT VERTICAL TACTILE F/B 50MI0A 12.0V 500MIOOHM 1T 1P
S217	55145270KX	1	PC	SWITACT VERTICAL TACTILE F/B 50MI0A 12.0V 500MIOOHM 1T 1P
S218	55145270KX	1	PC	SWITACT VERTICAL TACTILE F/B 50MI0A 12.0V 500MIOOHM 1T 1P
S219	55145270KX	1	PC	SWITACT VERTICAL TACTILE F/B 50MI0A 12.0V 500MIOOHM 1T 1P
S220	55145270KX	1	PC	SWITACT VERTICAL TACTILE F/B 50MI0A 12.0V 500MIOOHM 1T 1P
3 CHANNEL AMP				
<i>Capacitors</i>				
C109	552327300	1	PC	CE 120U0F +20% 100.0V 85C
C110	552327300	1	PC	CE 120U0F +20% 100.0V 85C
C111	552327300	1	PC	CE 120U0F +20% 100.0V 85C
C112	552327300	1	PC	CE 120U0F +20% 100.0V 85C
C209	552327300	1	PC	CE 120U0F +20% 100.0V 85C
C210	552327300	1	PC	CE 120U0F +20% 100.0V 85C
C211	552327300	1	PC	CE 120U0F +20% 100.0V 85C
C212	552327300	1	PC	CE 120U0F +20% 100.0V 85C
C309	552327300	1	PC	CE 120U0F +20% 100.0V 85C
C310	552327300	1	PC	CE 120U0F +20% 100.0V 85C
C311	552327300	1	PC	CE 120U0F +20% 100.0V 85C
C312	552327300	1	PC	CE 120U0F +20% 100.0V 85C
C101	1012100039	1	PC	CE 10U0F +20% 16.0V 85C
C102	3093623071	1	PC	CC 100P0F +5% -5% 50.0V NP0
C103	4043358071	1	PC	CC 680P0F +10% -10% 50.0V Y5P
C104	5524629039	1	PC	CE 100U0F +20% 25.0V 85C
C105	3093607071	1	PC	CC 12P0F +5% -5% 50.0V NP0
C106	7042837071	1	PC	CC 220P0F +10% -10% 50.0V Y5P
C107	2041669070	1	PC	CPM 100N0F +20% 250.0V
C108	2041669070	1	PC	CPM 100N0F +20% 250.0V
C113	2026901030	1	PC	CE 47U0F +20% 50.0V 85C
C114	2026901030	1	PC	CE 47U0F +20% 50.0V 85C
C115	1307794071	1	PC	CPF 10N0F +10% 100.0V
C116	1307794071	1	PC	CPF 10N0F +10% 100.0V
C117	5517940071	1	PC	CPM 68N0F +5% 63.0V
C118	2025267030	1	PC	CE 470U0F +20% 10.0V 85C
C161	1036482071	1	PC	CPF 47N0F +10% 100.0V
C162	1307201071	1	PC	CPF 4N7F +10% 100.0V
C164	1307201071	1	PC	CPF 4N7F +10% 100.0V
C201	1012100039	1	PC	CE 10U0F +20% 16.0V 85C
C202	3093623071	1	PC	CC 100P0F +5% -5% 50.0V NP0
C203	4043358071	1	PC	CC 680P0F +10% -10% 50.0V Y5P
C204	5524629039	1	PC	CE 100U0F +20% 25.0V 85C
C205	3093607071	1	PC	CC 12P0F +5% -5% 50.0V NP0
C206	7042837071	1	PC	CC 220P0F +10% -10% 50.0V Y5P
C207	2041669070	1	PC	CPM 100N0F +20% 250.0V
C208	2041669070	1	PC	CPM 100N0F +20% 250.0V
C213	2026901030	1	PC	CE 47U0F +20% 50.0V 85C

Ref Designator	Part Number	Qty		Description
3 CHANNEL AMP				
C214	2026901030	1	PC	CE 47U0F +20% 50.0V 85C
C215	1307794071	1	PC	CPF 10N0F +10% 100.0V
C216	1307794071	1	PC	CPF 10N0F +10% 100.0V
C217	5517940071	1	PC	CPM 68N0F +5% 63.0V
C218	2025267030	1	PC	CE 470U0F +20% 10.0V 85C
C261	1036482071	1	PC	CPF 47N0F +10% 100.0V
C262	1307201071	1	PC	CPF 4N7F +10% 100.0V
C264	1307201071	1	PC	CPF 4N7F +10% 100.0V
C301	1012100039	1	PC	CE 10U0F +20% 16.0V 85C
C302	3093623071	1	PC	CC 100P0F +5% -5% 50.0V NP0
C303	4043358071	1	PC	CC 680P0F +10% -10% 50.0V Y5P
C304	5524629039	1	PC	CE 100U0F +20% 25.0V 85C
C305	3093607071	1	PC	CC 12P0F +5% -5% 50.0V NP0
C306	7042837071	1	PC	CC 220P0F +10% -10% 50.0V Y5P
C307	2041669070	1	PC	CPM 100N0F +20% 250.0V
C308	2041669070	1	PC	CPM 100N0F +20% 250.0V
C313	2026901030	1	PC	CE 47U0F +20% 50.0V 85C
C314	2026901030	1	PC	CE 47U0F +20% 50.0V 85C
C315	1307794071	1	PC	CPF 10N0F +10% 100.0V
C316	1307794071	1	PC	CPF 10N0F +10% 100.0V
C317	5517940071	1	PC	CPM 68N0F +5% 63.0V
C318	2025267030	1	PC	CE 470U0F +20% 10.0V 85C
C361	1036482071	1	PC	CPF 47N0F +10% 100.0V
C362	1307201071	1	PC	CPF 4N7F +10% 100.0V
C364	1307201071	1	PC	CPF 4N7F +10% 100.0V
C901	2025267030	1	PC	CE 470U0F +20% 10.0V 85C
C902	2026884030	1	PC	CE 1U0F +20% 50.0V 85C
C903	2041669070	1	PC	CPM 100N0F +20% 250.0V
C904	2041669070	1	PC	CPM 100N0F +20% 250.0V
C917	2026898030	1	PC	CE 22U0F +20% 50.0V 85C
C918	2025267030	1	PC	CE 470U0F +20% 10.0V 85C
<i>Semiconductors</i>				
D107	20525530NR	1	PC	D-SR 1N4003 200.0V 1A
D207	20525530NR	1	PC	D-SR 1N4003 200.0V 1A
D307	20525530NR	1	PC	D-SR 1N4003 200.0V 1A
Q108	55231240NR	1	PC	TR-SLPLF 2SA1360Y P -50MI0A -150V
Q109	55231240NR	1	PC	TR-SLPLF 2SA1360Y P -50MI0A -150V
Q110	55231350NR	1	PC	TR-SLPLF 2SC3423Y N 50MI0A 150V
Q111	55231350NR	1	PC	TR-SLPLF 2SC3423Y N 50MI0A 150V
Q112	55133270NR	1	PC	TR-SHPLF 2SC4137 N 100MI0A 20V
Q114	55231350NR	1	PC	TR-SLPLF 2SC3423Y N 50MI0A 150V
Q115	55179190NR	1	PC	TR-SHPLF 2SA1859A P -2.0A
Q116	55231240NR	1	PC	TR-SLPLF 2SA1360Y P -50MI0A -150V
Q117	55179200NR	1	PC	TR-SHPLF 2SC4883A N 2.0A
Q118	551837900	1	PC	TR-SHPLF C5200-O(AC) N 15.0A
Q119	551837900	1	PC	TR-SHPLF C5200-O(AC) N 15.0A
Q120	551839300	1	PC	TR-SHPLF A1943-O(AC) P -15.0A
Q121	551839300	1	PC	TR-SHPLF A1943-O(AC) P -15.0A
Q208	55231240NR	1	PC	TR-SLPLF 2SA1360Y P -50MI0A -150V
Q209	55231240NR	1	PC	TR-SLPLF 2SA1360Y P -50MI0A -150V
Q210	55231350NR	1	PC	TR-SLPLF 2SC3423Y N 50MI0A 150V
Q211	55231350NR	1	PC	TR-SLPLF 2SC3423Y N 50MI0A 150V
Q212	55133270NR	1	PC	TR-SHPLF 2SC4137 N 100MI0A 20V
Q214	55231350NR	1	PC	TR-SLPLF 2SC3423Y N 50MI0A 150V
Q215	55179190NR	1	PC	TR-SHPLF 2SA1859A P -2.0A
Q216	55231240NR	1	PC	TR-SLPLF 2SA1360Y P -50MI0A -150V
Q217	55179200NR	1	PC	TR-SHPLF 2SC4883A N 2.0A
Q218	551837900	1	PC	TR-SHPLF C5200-O(AC) N 15.0A
Q219	551837900	1	PC	TR-SHPLF C5200-O(AC) N 15.0A
Q220	551839300	1	PC	TR-SHPLF A1943-O(AC) P -15.0A
Q221	551839300	1	PC	TR-SHPLF A1943-O(AC) P -15.0A
Q308	55231240NR	1	PC	TR-SLPLF 2SA1360Y P -50MI0A -150V
Q309	55231240NR	1	PC	TR-SLPLF 2SA1360Y P -50MI0A -150V
Q310	55231350NR	1	PC	TR-SLPLF 2SC3423Y N 50MI0A 150V
Q311	55231350NR	1	PC	TR-SLPLF 2SC3423Y N 50MI0A 150V

Ref Designator	Part Number	Qty		Description
3 CHANNEL AMP				
Q312	55133270NR	1	PC	TR-SHPLF 2SC4137 N 100MIOA 20V
Q314	55231350NR	1	PC	TR-SLPLF 2SC3423Y N 50MIOA 150V
Q315	55179190NR	1	PC	TR-SHPLF 2SA1859A P -2.0A
Q316	55231240NR	1	PC	TR-SLPLF 2SA1360Y P -50MIOA -150V
Q317	55179200NR	1	PC	TR-SHPLF 2SC4883A N 2.0A
Q318	551837900	1	PC	TR-SHPLF C5200-O(AC) N 15.0A
Q319	551837900	1	PC	TR-SHPLF C5200-O(AC) N 15.0A
Q320	551839300	1	PC	TR-SHPLF A1943-O(AC) P -15.0A
Q321	551839300	1	PC	TR-SHPLF A1943-O(AC) P -15.0A
Q101	2055660056	1	PC	TR-SHPLF KTC3200BL N 100MIOA 120V
Q102	2055660056	1	PC	TR-SHPLF KTC3200BL N 100MIOA 120V
Q103	2055660056	1	PC	TR-SHPLF KTC3200BL N 100MIOA 120V
Q104	2055660056	1	PC	TR-SHPLF KTC3200BL N 100MIOA 120V
Q105	2050808056	1	PC	TR-SLPLF KTC3198BL N 150MIOA
Q106	5531585056	1	PC	TR-SLPHF 2SA1370-E P 100MIOA 40 320
Q107	2064785056	1	PC	TR-SHPLF KTA1268BL P 100MIOA 120V
Q122	2055660056	1	PC	TR-SHPLF KTC3200BL N 100MIOA 120V
Q123	2050808056	1	PC	TR-SLPLF KTC3198BL N 150MIOA
Q201	2055660056	1	PC	TR-SHPLF KTC3200BL N 100MIOA 120V
Q202	2055660056	1	PC	TR-SHPLF KTC3200BL N 100MIOA 120V
Q203	2055660056	1	PC	TR-SHPLF KTC3200BL N 100MIOA 120V
Q204	2055660056	1	PC	TR-SHPLF KTC3200BL N 100MIOA 120V
Q205	2050808056	1	PC	TR-SLPLF KTC3198BL N 150MIOA
Q206	5531585056	1	PC	TR-SLPHF 2SA1370-E P 100MIOA 40 320
Q207	2064785056	1	PC	TR-SHPLF KTA1268BL P 100MIOA 120V
Q222	2055660056	1	PC	TR-SHPLF KTC3200BL N 100MIOA 120V
Q223	2050808056	1	PC	TR-SLPLF KTC3198BL N 150MIOA
Q301	2055660056	1	PC	TR-SHPLF KTC3200BL N 100MIOA 120V
Q302	2055660056	1	PC	TR-SHPLF KTC3200BL N 100MIOA 120V
Q303	2055660056	1	PC	TR-SHPLF KTC3200BL N 100MIOA 120V
Q304	2055660056	1	PC	TR-SHPLF KTC3200BL N 100MIOA 120V
Q305	2050808056	1	PC	TR-SLPLF KTC3198BL N 150MIOA
Q306	5531585056	1	PC	TR-SLPHF 2SA1370-E P 100MIOA 40 320
Q307	2064785056	1	PC	TR-SHPLF KTA1268BL P 100MIOA 120V
Q322	2055660056	1	PC	TR-SHPLF KTC3200BL N 100MIOA 120V
Q323	2050808056	1	PC	TR-SLPLF KTC3198BL N 150MIOA
Q901	5513326056	1	PC	TR-SLPLF KTA1024 Y P 50MIOA -150V
Q902	5513321056	1	PC	TR-SLPLF DTC114YSA N 100MIOA
Q925	2050821056	1	PC	TR-SLPLF KTA1266 Y P 150MIOA
Q926	5513325056	1	PC	TR-SLPLF 2SC1740S R N 150MIOA 50V
Q927	5513325056	1	PC	TR-SLPLF 2SC1740S R N 150MIOA 50V
Q928	5513325056	1	PC	TR-SLPLF 2SC1740S R N 150MIOA 50V
D101	7043654016	1	PC	D-SLP 1N4148 100.0V 150E-3A
D102	5523140016	1	PC	D-SLP 1SS244 220.0V 200MIOA
D103	5523140016	1	PC	D-SLP 1SS244 220.0V 200MIOA
D104	7043654016	1	PC	D-SLP 1N4148 100.0V 150E-3A
D105	7043654016	1	PC	D-SLP 1N4148 100.0V 150E-3A
D108	7043654016	1	PC	D-SLP 1N4148 100.0V 150E-3A
D201	7043654016	1	PC	D-SLP 1N4148 100.0V 150E-3A
D202	5523140016	1	PC	D-SLP 1SS244 220.0V 200MIOA
D203	5523140016	1	PC	D-SLP 1SS244 220.0V 200MIOA
D204	7043654016	1	PC	D-SLP 1N4148 100.0V 150E-3A
D205	7043654016	1	PC	D-SLP 1N4148 100.0V 150E-3A
D208	7043654016	1	PC	D-SLP 1N4148 100.0V 150E-3A
D301	7043654016	1	PC	D-SLP 1N4148 100.0V 150E-3A
D302	5523140016	1	PC	D-SLP 1SS244 220.0V 200MIOA
D303	5523140016	1	PC	D-SLP 1SS244 220.0V 200MIOA
D304	7043654016	1	PC	D-SLP 1N4148 100.0V 150E-3A
D305	7043654016	1	PC	D-SLP 1N4148 100.0V 150E-3A
D308	7043654016	1	PC	D-SLP 1N4148 100.0V 150E-3A
D901	7043654016	1	PC	D-SLP 1N4148 100.0V 150E-3A
D902	7043654016	1	PC	D-SLP 1N4148 100.0V 150E-3A
D907	20526960	1	PC	D-ZENER 1N5231B 5.1V 500MIOW
D908	7043654016	1	PC	D-SLP 1N4148 100.0V 150E-3A
D909	7043654016	1	PC	D-SLP 1N4148 100.0V 150E-3A
D910	7043654016	1	PC	D-SLP 1N4148 100.0V 150E-3A

Ref Designator	Part Number	Qty		Description
3 CHANNEL AMP				
<i>Resistors</i>				
R130	55232760NR	1	PC	RMF 56R0 OHM +5% 1.0W
R131	55232760NR	1	PC	RMF 56R0 OHM +5% 1.0W
R138	55232750NR	1	PC	RMF 2R2 OHM +5% 1.0W
R139	55232750NR	1	PC	RMF 2R2 OHM +5% 1.0W
R161	1502271016	1	PC	RMOF 10R0 OHM +5% 2.0W
R171	55307540NR	1	PC	RW 270MIO OHM +5% 5.0W 100PPM/C -100PPM/C
R172	55307540NR	1	PC	RW 270MIO OHM +5% 5.0W 100PPM/C -100PPM/C
R230	55232760NR	1	PC	RMF 56R0 OHM +5% 1.0W
R231	55232760NR	1	PC	RMF 56R0 OHM +5% 1.0W
R238	55232750NR	1	PC	RMF 2R2 OHM +5% 1.0W
R239	55232750NR	1	PC	RMF 2R2 OHM +5% 1.0W
R261	1502271016	1	PC	RMOF 10R0 OHM +5% 2.0W
R271	55307540NR	1	PC	RW 270MIO OHM +5% 5.0W 100PPM/C -100PPM/C
R272	55307540NR	1	PC	RW 270MIO OHM +5% 5.0W 100PPM/C -100PPM/C
R330	55232760NR	1	PC	RMF 56R0 OHM +5% 1.0W
R331	55232760NR	1	PC	RMF 56R0 OHM +5% 1.0W
R338	55232750NR	1	PC	RMF 2R2 OHM +5% 1.0W
R339	55232750NR	1	PC	RMF 2R2 OHM +5% 1.0W
R361	1502271016	1	PC	RMOF 10R0 OHM +5% 2.0W
R371	55307540NR	1	PC	RW 270MIO OHM +5% 5.0W 100PPM/C -100PPM/C
R372	55307540NR	1	PC	RW 270MIO OHM +5% 5.0W 100PPM/C -100PPM/C
R101	1105964016	1	PC	RCF 1K0 OHM +5% 250MIOW
R102	5523153016	1	PC	RMF 33K0 OHM +1% 125MIOW +100PPM/C
R103	4043563016	1	PC	RCF 1K5 OHM +5% 250MIOW
R104	4043563016	1	PC	RCF 1K5 OHM +5% 250MIOW
R105	5088297016	1	PC	RCF 470R0 OHM +5% 250MIOW
R106	5088295016	1	PC	RCF 100R0 OHM +5% 250MIOW
R107	5088295016	1	PC	RCF 100R0 OHM +5% 250MIOW
R108	5088295016	1	PC	RCF 100R0 OHM +5% 250MIOW
R109	2046945016	1	PC	RCF 220R0 OHM +5% 250MIOW
R110	5523280016	1	PC	RMF 82R0 OHM +5% 500MIOW
R111	5523153016	1	PC	RMF 33K0 OHM +1% 125MIOW +100PPM/C
R112	1106089016	1	PC	RMF 2K43 OHM +1% 250MIOW
R113	1501565016	1	PC	RMF 2K67 OHM +1% 250MIOW
R114	6044156016	1	PC	RCF 560R0 OHM +5% 250MIOW
R115	6044156016	1	PC	RCF 560R0 OHM +5% 250MIOW
R116	6044156016	1	PC	RCF 560R0 OHM +5% 250MIOW
R117	6044156016	1	PC	RCF 560R0 OHM +5% 250MIOW
R118	6044156016	1	PC	RCF 560R0 OHM +5% 250MIOW
R119	6044156016	1	PC	RCF 560R0 OHM +5% 250MIOW
R120	5088296016	1	PC	RCF 150R0 OHM +5% 250MIOW
R121	5088296016	1	PC	RCF 150R0 OHM +5% 250MIOW
R122	5088296016	1	PC	RCF 150R0 OHM +5% 250MIOW
R123	5088296016	1	PC	RCF 150R0 OHM +5% 250MIOW
R124	5088301016	1	PC	RCF 15K0 OHM +5% 250MIOW
R125	5088301016	1	PC	RCF 15K0 OHM +5% 250MIOW
R126	2046946016	1	PC	RCF 2K2 OHM +5% 250MIOW
R129	8043698016	1	PC	RCF 620R0 OHM +5% 250MIOW
R132	5523277016	1	PC	RMF 2R2 OHM +5% 500MIOW
R133	5523277016	1	PC	RMF 2R2 OHM +5% 500MIOW
R134	5523278016	1	PC	RMF 100R0 OHM +5% 500MIOW
R135	5523278016	1	PC	RMF 100R0 OHM +5% 500MIOW
R136	5523279016	1	PC	RMF 15R0 OHM +5% 500MIOW
R137	5523279016	1	PC	RMF 15R0 OHM +5% 500MIOW
R140	5523281016	1	PC	RMF 10R0 OHM +5% 500MIOW
R141	5523281016	1	PC	RMF 10R0 OHM +5% 500MIOW
R142	5523281016	1	PC	RMF 10R0 OHM +5% 500MIOW
R143	5523281016	1	PC	RMF 10R0 OHM +5% 500MIOW
R144	8043700016	1	PC	RCF 1K2 OHM +5% 250MIOW
R145	8043700016	1	PC	RCF 1K2 OHM +5% 250MIOW
R146	5088301016	1	PC	RCF 15K0 OHM +5% 250MIOW
R147	2046949016	1	PC	RCF 6K8 OHM +5% 250MIOW
R148	3093938016	1	PC	RCF 22R0 OHM +5% 250MIOW
R149	3093938016	1	PC	RCF 22R0 OHM +5% 250MIOW
R150	3093949016	1	PC	RCF 33K0 OHM +5% 250MIOW

Ref Designator	Part Number	Qty		Description
3 CHANNEL AMP				
R155	4043567016	1	PC	RCF 47K0 OHM +5% 250MI0W
R156	2046946016	1	PC	RCF 2K2 OHM +5% 250MI0W
R157	1105958016	1	PC	RCF 56R0 OHM +5% 250MI0W
R170	4043567016	1	PC	RCF 47K0 OHM +5% 250MI0W
R201	1105964016	1	PC	RCF 1K0 OHM +5% 250MI0W
R202	5523153016	1	PC	RMF 33K0 OHM +1% 125MI0W +100PPM/C
R203	4043563016	1	PC	RCF 1K5 OHM +5% 250MI0W
R204	4043563016	1	PC	RCF 1K5 OHM +5% 250MI0W
R205	5088297016	1	PC	RCF 470R0 OHM +5% 250MI0W
R206	5088295016	1	PC	RCF 100R0 OHM +5% 250MI0W
R207	5088295016	1	PC	RCF 100R0 OHM +5% 250MI0W
R208	5088295016	1	PC	RCF 100R0 OHM +5% 250MI0W
R209	2046945016	1	PC	RCF 220R0 OHM +5% 250MI0W
R210	5523280016	1	PC	RMF 82R0 OHM +5% 500MI0W
R211	5523153016	1	PC	RMF 33K0 OHM +1% 125MI0W +100PPM/C
R212	1106089016	1	PC	RMF 2K43 OHM +1% 250MI0W
R213	1501565016	1	PC	RMF 2K67 OHM +1% 250MI0W
R214	6044156016	1	PC	RCF 560R0 OHM +5% 250MI0W
R215	6044156016	1	PC	RCF 560R0 OHM +5% 250MI0W
R216	6044156016	1	PC	RCF 560R0 OHM +5% 250MI0W
R217	6044156016	1	PC	RCF 560R0 OHM +5% 250MI0W
R218	6044156016	1	PC	RCF 560R0 OHM +5% 250MI0W
R219	6044156016	1	PC	RCF 560R0 OHM +5% 250MI0W
R220	5088296016	1	PC	RCF 150R0 OHM +5% 250MI0W
R221	5088296016	1	PC	RCF 150R0 OHM +5% 250MI0W
R222	5088296016	1	PC	RCF 150R0 OHM +5% 250MI0W
R223	5088296016	1	PC	RCF 150R0 OHM +5% 250MI0W
R224	5088301016	1	PC	RCF 15K0 OHM +5% 250MI0W
R225	5088301016	1	PC	RCF 15K0 OHM +5% 250MI0W
R226	2046946016	1	PC	RCF 2K2 OHM +5% 250MI0W
R229	8043698016	1	PC	RCF 620R0 OHM +5% 250MI0W
R232	5523277016	1	PC	RMF 2R2 OHM +5% 500MI0W
R233	5523277016	1	PC	RMF 2R2 OHM +5% 500MI0W
R234	5523278016	1	PC	RMF 100R0 OHM +5% 500MI0W
R235	5523278016	1	PC	RMF 100R0 OHM +5% 500MI0W
R236	5523279016	1	PC	RMF 15R0 OHM +5% 500MI0W
R237	5523279016	1	PC	RMF 15R0 OHM +5% 500MI0W
R240	5523281016	1	PC	RMF 10R0 OHM +5% 500MI0W
R241	5523281016	1	PC	RMF 10R0 OHM +5% 500MI0W
R242	5523281016	1	PC	RMF 10R0 OHM +5% 500MI0W
R243	5523281016	1	PC	RMF 10R0 OHM +5% 500MI0W
R244	8043700016	1	PC	RCF 1K2 OHM +5% 250MI0W
R245	8043700016	1	PC	RCF 1K2 OHM +5% 250MI0W
R246	5088301016	1	PC	RCF 15K0 OHM +5% 250MI0W
R247	2046949016	1	PC	RCF 6K8 OHM +5% 250MI0W
R248	3093938016	1	PC	RCF 22R0 OHM +5% 250MI0W
R249	3093938016	1	PC	RCF 22R0 OHM +5% 250MI0W
R250	3093949016	1	PC	RCF 33K0 OHM +5% 250MI0W
R255	4043567016	1	PC	RCF 47K0 OHM +5% 250MI0W
R256	2046946016	1	PC	RCF 2K2 OHM +5% 250MI0W
R257	1105958016	1	PC	RCF 56R0 OHM +5% 250MI0W
R270	4043567016	1	PC	RCF 47K0 OHM +5% 250MI0W
R301	1105964016	1	PC	RCF 1K0 OHM +5% 250MI0W
R302	5523153016	1	PC	RMF 33K0 OHM +1% 125MI0W +100PPM/C
R303	4043563016	1	PC	RCF 1K5 OHM +5% 250MI0W
R304	4043563016	1	PC	RCF 1K5 OHM +5% 250MI0W
R305	5088297016	1	PC	RCF 470R0 OHM +5% 250MI0W
R306	5088295016	1	PC	RCF 100R0 OHM +5% 250MI0W
R307	5088295016	1	PC	RCF 100R0 OHM +5% 250MI0W
R308	5088295016	1	PC	RCF 100R0 OHM +5% 250MI0W
R309	2046945016	1	PC	RCF 220R0 OHM +5% 250MI0W
R310	5523280016	1	PC	RMF 82R0 OHM +5% 500MI0W
R311	5523153016	1	PC	RMF 33K0 OHM +1% 125MI0W +100PPM/C
R312	1106089016	1	PC	RMF 2K43 OHM +1% 250MI0W
R313	1501565016	1	PC	RMF 2K67 OHM +1% 250MI0W
R314	6044156016	1	PC	RCF 560R0 OHM +5% 250MI0W
R315	6044156016	1	PC	RCF 560R0 OHM +5% 250MI0W

Ref Designator	Part Number	Qty		Description
3 CHANNEL AMP				
R316	6044156016	1	PC	RCF 560R0 OHM +5% 250MIOW
R317	6044156016	1	PC	RCF 560R0 OHM +5% 250MIOW
R318	6044156016	1	PC	RCF 560R0 OHM +5% 250MIOW
R319	6044156016	1	PC	RCF 560R0 OHM +5% 250MIOW
R320	5088296016	1	PC	RCF 150R0 OHM +5% 250MIOW
R321	5088296016	1	PC	RCF 150R0 OHM +5% 250MIOW
R322	5088296016	1	PC	RCF 150R0 OHM +5% 250MIOW
R323	5088296016	1	PC	RCF 150R0 OHM +5% 250MIOW
R324	5088301016	1	PC	RCF 15K0 OHM +5% 250MIOW
R325	5088301016	1	PC	RCF 15K0 OHM +5% 250MIOW
R326	2046946016	1	PC	RCF 2K2 OHM +5% 250MIOW
R329	8043698016	1	PC	RCF 620R0 OHM +5% 250MIOW
R332	5523277016	1	PC	RMF 2R2 OHM +5% 500MIOW
R333	5523277016	1	PC	RMF 2R2 OHM +5% 500MIOW
R334	5523278016	1	PC	RMF 100R0 OHM +5% 500MIOW
R335	5523278016	1	PC	RMF 100R0 OHM +5% 500MIOW
R336	5523279016	1	PC	RMF 15R0 OHM +5% 500MIOW
R337	5523279016	1	PC	RMF 15R0 OHM +5% 500MIOW
R340	5523281016	1	PC	RMF 10R0 OHM +5% 500MIOW
R341	5523281016	1	PC	RMF 10R0 OHM +5% 500MIOW
R342	5523281016	1	PC	RMF 10R0 OHM +5% 500MIOW
R343	5523281016	1	PC	RMF 10R0 OHM +5% 500MIOW
R344	8043700016	1	PC	RCF 1K2 OHM +5% 250MIOW
R345	8043700016	1	PC	RCF 1K2 OHM +5% 250MIOW
R346	5088301016	1	PC	RCF 15K0 OHM +5% 250MIOW
R347	2046949016	1	PC	RCF 6K8 OHM +5% 250MIOW
R348	3093938016	1	PC	RCF 22R0 OHM +5% 250MIOW
R349	3093938016	1	PC	RCF 22R0 OHM +5% 250MIOW
R350	3093949016	1	PC	RCF 33K0 OHM +5% 250MIOW
R355	4043567016	1	PC	RCF 47K0 OHM +5% 250MIOW
R356	2046946016	1	PC	RCF 2K2 OHM +5% 250MIOW
R357	1105958016	1	PC	RCF 56R0 OHM +5% 250MIOW
R370	4043567016	1	PC	RCF 47K0 OHM +5% 250MIOW
R901	6044154016	1	PC	RCF 180R0 OHM +5% 250MIOW
R902	4043567016	1	PC	RCF 47K0 OHM +5% 250MIOW
R961	3093951016	1	PC	RCF 100K0 OHM +5% 250MIOW
R962	6044160016	1	PC	RCF 68K0 OHM +5% 250MIOW
R963	3093948016	1	PC	RCF 10K0 OHM +5% 250MIOW
R964	7043056016	1	PC	RCF 5K6 OHM +5% 250MIOW
R965	1105964016	1	PC	RCF 1K0 OHM +5% 250MIOW
R966	3093951016	1	PC	RCF 100K0 OHM +5% 250MIOW
R967	8043701016	1	PC	RCF 1K8 OHM +5% 250MIOW
R968	8043701016	1	PC	RCF 1K8 OHM +5% 250MIOW
R969	5088300016	1	PC	RCF 3K3 OHM +5% 250MIOW
R971	3093951016	1	PC	RCF 100K0 OHM +5% 250MIOW
R972	3093951016	1	PC	RCF 100K0 OHM +5% 250MIOW
R973	3093949016	1	PC	RCF 33K0 OHM +5% 250MIOW
VR11	55250310NR	1	PC	PR 50R0 OHM +20% 500MIOW
VR12	55250320NR	1	PC	PR 200R0 OHM +20% 500MIOW
VR21	55250310NR	1	PC	PR 50R0 OHM +20% 500MIOW
VR22	55250320NR	1	PC	PR 200R0 OHM +20% 500MIOW
VR31	55250310NR	1	PC	PR 50R0 OHM +20% 500MIOW
VR32	55250320NR	1	PC	PR 200R0 OHM +20% 500MIOW
<i>Miscellaneous</i>				
G101	55135980NR	1	PC	TERMLUG GND
G201	55135980NR	1	PC	TERMLUG GND
G301	55135980NR	1	PC	TERMLUG GND
G302	55135980NR	1	PC	TERMLUG GND
G303	55135980NR	1	PC	TERMLUG GND
L101	55179560NR	1	PC	LFA 1MM 10MM 5 LEFT 0.0MM NONE
L201	55179560NR	1	PC	LFA 1MM 10MM 5 LEFT 0.0MM NONE
L301	55179560NR	1	PC	LFA 1MM 10MM 5 LEFT 0.0MM NONE
N101	557207100	1	PC	WIRECONASY UNIQUE 7 180MM UL1007 RIBBON 24 1
N201	556868100	1	PC	WIRECONASY UNIQUE 5P 150MM UL1007 RIBBON 24 1
N301	556868300	1	PC	WIRECONASY UNIQUE 4P 250MM UL1007 RIBBON 24 1
N901	556869500	1	PC	WIRECONASY UNIQUE 3P 230MM UL1007 PVC DISCRETE 18 12

Ref Designator	Part Number	Qty		Description
3 CHANNEL AMP				
N902	556869600	1	PC	WIRECONASY UNIQUE 2P 250MM UL1007 PVC DISCRETE 18 12
N903	556867400	1	PC	WIRECONASY UNIQUE 3P 150MM UL1007 PVC DISCRETE 16 1
N904	556866000	1	PC	WIRECONASY UNIQUE 2P 150MM UL1007 PVC DISCRETE 16 1
N906	555873900	1	PC	POS 100R0 OHM 16.0V
NJ11	55637170NR	1	PC	CONN-SPE SPEAKER TER'BOARD(2P) BK/WH D/N B30290117N
NJ21	55637180NR	1	PC	CONN-SPE SPEAKER TER'BOARD(2P) BK/BU D/N B30290118N
NJ31	55637190NR	1	PC	CONN-SPE SPEAKER TER'BOARD(2P) BK/BN D/N B30290119N E1474
P101	55146560	1	PC	CONN 2.5MM 2 MA ST NAT 0 0
P106	55171540	1	PC	CONN 2.0MM 7 MA ST NAT MOLEX 35336-0710 0 0
P201	55146560	1	PC	CONN 2.5MM 2 MA ST NAT 0 0
P202	55146570	1	PC	CONN 2.5MM 3 MA ST NAT 0 0
P206	55171540	1	PC	CONN 2.0MM 7 MA ST NAT MOLEX 35336-0710 0 0
P301	55146560	1	PC	CONN 2.5MM 2 MA ST NAT 0 0
P306	55171540	1	PC	CONN 2.0MM 7 MA ST NAT MOLEX 35336-0710 0 0
P413	55171570	1	PC	CONN 2.0MM 7 MA R NAT BD'BD SOCKET MOLEX 35237-0710 0 0
P414	55171570	1	PC	CONN 2.0MM 7 MA R NAT BD'BD SOCKET MOLEX 35237-0710 0 0
P415	55171570	1	PC	CONN 2.0MM 7 MA R NAT BD'BD SOCKET MOLEX 35237-0710 0 0
P802	55169140	1	PC	CON 3.96MM PITCH MOREX 35313-0210
P906	55146560	1	PC	CONN 2.5MM 2 MA ST NAT 0 0
W101	556871200	1	PC	WIRESSTRINS 4.0 CU WIRE 78MM BK 80C Y
W102	556871200	1	PC	WIRESSTRINS 4.0 CU WIRE 78MM BK 80C Y
W103	556871200	1	PC	WIRESSTRINS 4.0 CU WIRE 78MM BK 80C Y
W104	556871200	1	PC	WIRESSTRINS 4.0 CU WIRE 78MM BK 80C Y
B101	5517951018	1	PC	LFBEAD 44.1653OHM 100M0HZ FB-30 HC-3550
B102	5517951018	1	PC	LFBEAD 44.1653OHM 100M0HZ FB-30 HC-3550
B103	5517951018	1	PC	LFBEAD 44.1653OHM 100M0HZ FB-30 HC-3550
B104	5517951018	1	PC	LFBEAD 44.1653OHM 100M0HZ FB-30 HC-3550
B201	5517951018	1	PC	LFBEAD 44.1653OHM 100M0HZ FB-30 HC-3550
B202	5517951018	1	PC	LFBEAD 44.1653OHM 100M0HZ FB-30 HC-3550
B203	5517951018	1	PC	LFBEAD 44.1653OHM 100M0HZ FB-30 HC-3550
B204	5517951018	1	PC	LFBEAD 44.1653OHM 100M0HZ FB-30 HC-3550
B301	5517951018	1	PC	LFBEAD 44.1653OHM 100M0HZ FB-30 HC-3550
B302	5517951018	1	PC	LFBEAD 44.1653OHM 100M0HZ FB-30 HC-3550
B303	5517951018	1	PC	LFBEAD 44.1653OHM 100M0HZ FB-30 HC-3550
B304	5517951018	1	PC	LFBEAD 44.1653OHM 100M0HZ FB-30 HC-3550
SK11	55568280NR	1	PC	RELAYSGNL 24.0V 1K1OHM 5.0A
SK21	55568280NR	1	PC	RELAYSGNL 24.0V 1K1OHM 5.0A
SK31	55568280NR	1	PC	RELAYSGNL 24.0V 1K1OHM 5.0A
4 CHANNEL AMP				
<i>Capacitors</i>				
C409	552327300	1	PC	CE 120U0F +20% 100.0V 85C
C410	552327300	1	PC	CE 120U0F +20% 100.0V 85C
C411	552327300	1	PC	CE 120U0F +20% 100.0V 85C
C412	552327300	1	PC	CE 120U0F +20% 100.0V 85C
C509	552327300	1	PC	CE 120U0F +20% 100.0V 85C
C510	552327300	1	PC	CE 120U0F +20% 100.0V 85C
C511	552327300	1	PC	CE 120U0F +20% 100.0V 85C
C512	552327300	1	PC	CE 120U0F +20% 100.0V 85C
C609	552327300	1	PC	CE 120U0F +20% 100.0V 85C
C610	552327300	1	PC	CE 120U0F +20% 100.0V 85C
C611	552327300	1	PC	CE 120U0F +20% 100.0V 85C
C612	552327300	1	PC	CE 120U0F +20% 100.0V 85C
C709	552327300	1	PC	CE 120U0F +20% 100.0V 85C
C710	552327300	1	PC	CE 120U0F +20% 100.0V 85C
C711	552327300	1	PC	CE 120U0F +20% 100.0V 85C
C712	552327300	1	PC	CE 120U0F +20% 100.0V 85C
C401	1012100039	1	PC	CE 10U0F +20% 16.0V 85C
C402	3093623071	1	PC	CC 100P0F +5% -5% 50.0V NP0
C403	4043358071	1	PC	CC 680P0F +10% -10% 50.0V Y5P
C404	5524629039	1	PC	CE 100U0F +20% 25.0V 85C
C405	3093607071	1	PC	CC 12P0F +5% -5% 50.0V NP0
C406	7042837071	1	PC	CC 220P0F +10% -10% 50.0V Y5P
C407	2041669070	1	PC	CPM 100N0F +20% 250.0V
C408	2041669070	1	PC	CPM 100N0F +20% 250.0V

Ref Designator	Part Number	Qty		Description
4 CHANNEL AMP				
C413	2026901030	1	PC	CE 47U0F +20% 50.0V 85C
C414	2026901030	1	PC	CE 47U0F +20% 50.0V 85C
C415	1307794071	1	PC	CPF 10N0F +10% 100.0V
C416	1307794071	1	PC	CPF 10N0F +10% 100.0V
C417	5517940071	1	PC	CPM 68N0F +5% 63.0V
C418	2025267030	1	PC	CE 470U0F +20% 10.0V 85C
C461	1036482071	1	PC	CPF 47N0F +10% 100.0V
C462	1307201071	1	PC	CPF 4N7F +10% 100.0V
C464	1307201071	1	PC	CPF 4N7F +10% 100.0V
C501	1012100039	1	PC	CE 10U0F +20% 16.0V 85C
C502	3093623071	1	PC	CC 100P0F +5% -5% 50.0V NP0
C503	4043358071	1	PC	CC 680P0F +10% -10% 50.0V Y5P
C504	5524629039	1	PC	CE 100U0F +20% 25.0V 85C
C505	3093607071	1	PC	CC 12P0F +5% -5% 50.0V NP0
C506	7042837071	1	PC	CC 220P0F +10% -10% 50.0V Y5P
C507	2041669070	1	PC	CPM 100N0F +20% 250.0V
C508	2041669070	1	PC	CPM 100N0F +20% 250.0V
C513	2026901030	1	PC	CE 47U0F +20% 50.0V 85C
C514	2026901030	1	PC	CE 47U0F +20% 50.0V 85C
C515	1307794071	1	PC	CPF 10N0F +10% 100.0V
C516	1307794071	1	PC	CPF 10N0F +10% 100.0V
C517	5517940071	1	PC	CPM 68N0F +5% 63.0V
C518	2025267030	1	PC	CE 470U0F +20% 10.0V 85C
C561	1036482071	1	PC	CPF 47N0F +10% 100.0V
C562	1307201071	1	PC	CPF 4N7F +10% 100.0V
C564	1307201071	1	PC	CPF 4N7F +10% 100.0V
C601	1012100039	1	PC	CE 10U0F +20% 16.0V 85C
C602	3093623071	1	PC	CC 100P0F +5% -5% 50.0V NP0
C603	4043358071	1	PC	CC 680P0F +10% -10% 50.0V Y5P
C604	5524629039	1	PC	CE 100U0F +20% 25.0V 85C
C605	3093607071	1	PC	CC 12P0F +5% -5% 50.0V NP0
C606	7042837071	1	PC	CC 220P0F +10% -10% 50.0V Y5P
C607	2041669070	1	PC	CPM 100N0F +20% 250.0V
C608	2041669070	1	PC	CPM 100N0F +20% 250.0V
C613	2026901030	1	PC	CE 47U0F +20% 50.0V 85C
C614	2026901030	1	PC	CE 47U0F +20% 50.0V 85C
C615	1307794071	1	PC	CPF 10N0F +10% 100.0V
C616	1307794071	1	PC	CPF 10N0F +10% 100.0V
C617	5517940071	1	PC	CPM 68N0F +5% 63.0V
C618	2025267030	1	PC	CE 470U0F +20% 10.0V 85C
C661	1036482071	1	PC	CPF 47N0F +10% 100.0V
C662	1307201071	1	PC	CPF 4N7F +10% 100.0V
C664	1307201071	1	PC	CPF 4N7F +10% 100.0V
C701	1012100039	1	PC	CE 10U0F +20% 16.0V 85C
C702	3093623071	1	PC	CC 100P0F +5% -5% 50.0V NP0
C703	4043358071	1	PC	CC 680P0F +10% -10% 50.0V Y5P
C704	5524629039	1	PC	CE 100U0F +20% 25.0V 85C
C705	3093607071	1	PC	CC 12P0F +5% -5% 50.0V NP0
C706	7042837071	1	PC	CC 220P0F +10% -10% 50.0V Y5P
C707	2041669070	1	PC	CPM 100N0F +20% 250.0V
C708	2041669070	1	PC	CPM 100N0F +20% 250.0V
C713	2026901030	1	PC	CE 47U0F +20% 50.0V 85C
C714	2026901030	1	PC	CE 47U0F +20% 50.0V 85C
C715	1307794071	1	PC	CPF 10N0F +10% 100.0V
C716	1307794071	1	PC	CPF 10N0F +10% 100.0V
C717	5517940071	1	PC	CPM 68N0F +5% 63.0V
C718	2025267030	1	PC	CE 470U0F +20% 10.0V 85C
C761	1036482071	1	PC	CPF 47N0F +10% 100.0V
C762	1307201071	1	PC	CPF 4N7F +10% 100.0V
C764	1307201071	1	PC	CPF 4N7F +10% 100.0V
C801	2025267030	1	PC	CE 470U0F +20% 10.0V 85C
C802	2026884030	1	PC	CE 1U0F +20% 50.0V 85C
C803	2041669070	1	PC	CPM 100N0F +20% 250.0V
C804	2041669070	1	PC	CPM 100N0F +20% 250.0V

Ref Designator	Part Number	Qty		Description
4 CHANNEL AMP				
<i>Semiconductors</i>				
D407	20525530NR	1	PC	D-SR 1N4003 200.0V 1A
D507	20525530NR	1	PC	D-SR 1N4003 200.0V 1A
D607	20525530NR	1	PC	D-SR 1N4003 200.0V 1A
D707	20525530NR	1	PC	D-SR 1N4003 200.0V 1A
Q408	55231240NR	1	PC	TR-SLPLF 2SA1360Y P -50MIOA -150V
Q409	55231240NR	1	PC	TR-SLPLF 2SA1360Y P -50MIOA -150V
Q410	55231350NR	1	PC	TR-SLPLF 2SC3423Y N 50MIOA 150V
Q411	55231350NR	1	PC	TR-SLPLF 2SC3423Y N 50MIOA 150V
Q412	55133270NR	1	PC	TR-SHPLF 2SC4137 N 100MIOA 20V
Q414	55231350NR	1	PC	TR-SLPLF 2SC3423Y N 50MIOA 150V
Q415	55179190NR	1	PC	TR-SHPLF 2SA1859A P -2.0A
Q416	55231240NR	1	PC	TR-SLPLF 2SA1360Y P -50MIOA -150V
Q417	55179200NR	1	PC	TR-SHPLF 2SC4883A N 2.0A
Q418	551837900	1	PC	TR-SHPLF C5200-O(AC) N 15.0A
Q419	551837900	1	PC	TR-SHPLF C5200-O(AC) N 15.0A
Q420	551839300	1	PC	TR-SHPLF A1943-O(AC) P -15.0A
Q421	551839300	1	PC	TR-SHPLF A1943-O(AC) P -15.0A
Q508	55231240NR	1	PC	TR-SLPLF 2SA1360Y P -50MIOA -150V
Q509	55231240NR	1	PC	TR-SLPLF 2SA1360Y P -50MIOA -150V
Q510	55231350NR	1	PC	TR-SLPLF 2SC3423Y N 50MIOA 150V
Q511	55231350NR	1	PC	TR-SLPLF 2SC3423Y N 50MIOA 150V
Q512	55133270NR	1	PC	TR-SHPLF 2SC4137 N 100MIOA 20V
Q514	55231350NR	1	PC	TR-SLPLF 2SC3423Y N 50MIOA 150V
Q515	55179190NR	1	PC	TR-SHPLF 2SA1859A P -2.0A
Q516	55231240NR	1	PC	TR-SLPLF 2SA1360Y P -50MIOA -150V
Q517	55179200NR	1	PC	TR-SHPLF 2SC4883A N 2.0A
Q518	551837900	1	PC	TR-SHPLF C5200-O(AC) N 15.0A
Q519	551837900	1	PC	TR-SHPLF C5200-O(AC) N 15.0A
Q520	551839300	1	PC	TR-SHPLF A1943-O(AC) P -15.0A
Q521	551839300	1	PC	TR-SHPLF A1943-O(AC) P -15.0A
Q608	55231240NR	1	PC	TR-SLPLF 2SA1360Y P -50MIOA -150V
Q609	55231240NR	1	PC	TR-SLPLF 2SA1360Y P -50MIOA -150V
Q610	55231350NR	1	PC	TR-SLPLF 2SC3423Y N 50MIOA 150V
Q611	55231350NR	1	PC	TR-SLPLF 2SC3423Y N 50MIOA 150V
Q612	55133270NR	1	PC	TR-SHPLF 2SC4137 N 100MIOA 20V
Q614	55231350NR	1	PC	TR-SLPLF 2SC3423Y N 50MIOA 150V
Q615	55179190NR	1	PC	TR-SHPLF 2SA1859A P -2.0A
Q616	55231240NR	1	PC	TR-SLPLF 2SA1360Y P -50MIOA -150V
Q617	55179200NR	1	PC	TR-SHPLF 2SC4883A N 2.0A
Q618	551837900	1	PC	TR-SHPLF C5200-O(AC) N 15.0A
Q619	551837900	1	PC	TR-SHPLF C5200-O(AC) N 15.0A
Q620	551839300	1	PC	TR-SHPLF A1943-O(AC) P -15.0A
Q621	551839300	1	PC	TR-SHPLF A1943-O(AC) P -15.0A
Q708	55231240NR	1	PC	TR-SLPLF 2SA1360Y P -50MIOA -150V
Q709	55231240NR	1	PC	TR-SLPLF 2SA1360Y P -50MIOA -150V
Q710	55231350NR	1	PC	TR-SLPLF 2SC3423Y N 50MIOA 150V
Q711	55231350NR	1	PC	TR-SLPLF 2SC3423Y N 50MIOA 150V
Q712	55133270NR	1	PC	TR-SHPLF 2SC4137 N 100MIOA 20V
Q714	55231350NR	1	PC	TR-SLPLF 2SC3423Y N 50MIOA 150V
Q715	55179190NR	1	PC	TR-SHPLF 2SA1859A P -2.0A
Q716	55231240NR	1	PC	TR-SLPLF 2SA1360Y P -50MIOA -150V
Q717	55179200NR	1	PC	TR-SHPLF 2SC4883A N 2.0A
Q718	551837900	1	PC	TR-SHPLF C5200-O(AC) N 15.0A
Q719	551837900	1	PC	TR-SHPLF C5200-O(AC) N 15.0A
Q720	551839300	1	PC	TR-SHPLF A1943-O(AC) P -15.0A
Q721	551839300	1	PC	TR-SHPLF A1943-O(AC) P -15.0A
Q401	2055660056	1	PC	TR-SHPLF KTC3200BL N 100MIOA 120V
Q402	2055660056	1	PC	TR-SHPLF KTC3200BL N 100MIOA 120V
Q403	2055660056	1	PC	TR-SHPLF KTC3200BL N 100MIOA 120V
Q404	2050808056	1	PC	TR-SLPLF KTC3198BL N 150MIOA
Q405	2050808056	1	PC	TR-SLPLF KTC3198BL N 150MIOA
Q406	5531585056	1	PC	TR-SLPHF 2SA1370-E P 100MIOA 40 320
Q407	2064785056	1	PC	TR-SHPLF KTA1268BL P 100MIOA 120V
Q422	2055660056	1	PC	TR-SHPLF KTC3200BL N 100MIOA 120V
Q423	2050808056	1	PC	TR-SLPLF KTC3198BL N 150MIOA

Ref Designator	Part Number	Qty		Description
4 CHANNEL AMP				
Q501	2055660056	1	PC	TR-SHPLF KTC3200BL N 100MIOA 120V
Q502	2055660056	1	PC	TR-SHPLF KTC3200BL N 100MIOA 120V
Q503	2055660056	1	PC	TR-SHPLF KTC3200BL N 100MIOA 120V
Q504	2050808056	1	PC	TR-SLPLF KTC3198BL N 150MIOA
Q505	2050808056	1	PC	TR-SLPLF KTC3198BL N 150MIOA
Q506	5531585056	1	PC	TR-SLPHF 2SA1370-E P 100MIOA 40 320
Q507	2064785056	1	PC	TR-SHPLF KTA1268BL P 100MIOA 120V
Q522	2055660056	1	PC	TR-SHPLF KTC3200BL N 100MIOA 120V
Q523	2050808056	1	PC	TR-SLPLF KTC3198BL N 150MIOA
Q601	2055660056	1	PC	TR-SHPLF KTC3200BL N 100MIOA 120V
Q602	2055660056	1	PC	TR-SHPLF KTC3200BL N 100MIOA 120V
Q603	2055660056	1	PC	TR-SHPLF KTC3200BL N 100MIOA 120V
Q604	2050808056	1	PC	TR-SLPLF KTC3198BL N 150MIOA
Q605	2050808056	1	PC	TR-SLPLF KTC3198BL N 150MIOA
Q606	5531585056	1	PC	TR-SLPHF 2SA1370-E P 100MIOA 40 320
Q607	2064785056	1	PC	TR-SHPLF KTA1268BL P 100MIOA 120V
Q622	2055660056	1	PC	TR-SHPLF KTC3200BL N 100MIOA 120V
Q623	2050808056	1	PC	TR-SLPLF KTC3198BL N 150MIOA
Q701	2055660056	1	PC	TR-SHPLF KTC3200BL N 100MIOA 120V
Q702	2055660056	1	PC	TR-SHPLF KTC3200BL N 100MIOA 120V
Q703	2055660056	1	PC	TR-SHPLF KTC3200BL N 100MIOA 120V
Q704	2050808056	1	PC	TR-SLPLF KTC3198BL N 150MIOA
Q705	2050808056	1	PC	TR-SLPLF KTC3198BL N 150MIOA
Q706	5531585056	1	PC	TR-SLPHF 2SA1370-E P 100MIOA 40 320
Q707	2064785056	1	PC	TR-SHPLF KTA1268BL P 100MIOA 120V
Q722	2055660056	1	PC	TR-SHPLF KTC3200BL N 100MIOA 120V
Q723	2050808056	1	PC	TR-SLPLF KTC3198BL N 150MIOA
Q801	5513326056	1	PC	TR-SLPLF KTA1024 Y P 50MIOA -150V
Q802	5513321056	1	PC	TR-SLPLF DTC114YSA N 100MIOA
D401	7043654016	1	PC	D-SLP 1N4148 100.0V 150E-3A
D402	5523140016	1	PC	D-SLP 1SS244 220.0V 200MIOA
D403	5523140016	1	PC	D-SLP 1SS244 220.0V 200MIOA
D404	7043654016	1	PC	D-SLP 1N4148 100.0V 150E-3A
D405	7043654016	1	PC	D-SLP 1N4148 100.0V 150E-3A
D408	7043654016	1	PC	D-SLP 1N4148 100.0V 150E-3A
D501	7043654016	1	PC	D-SLP 1N4148 100.0V 150E-3A
D502	5523140016	1	PC	D-SLP 1SS244 220.0V 200MIOA
D503	5523140016	1	PC	D-SLP 1SS244 220.0V 200MIOA
D504	7043654016	1	PC	D-SLP 1N4148 100.0V 150E-3A
D505	7043654016	1	PC	D-SLP 1N4148 100.0V 150E-3A
D508	7043654016	1	PC	D-SLP 1N4148 100.0V 150E-3A
D601	7043654016	1	PC	D-SLP 1N4148 100.0V 150E-3A
D602	5523140016	1	PC	D-SLP 1SS244 220.0V 200MIOA
D603	5523140016	1	PC	D-SLP 1SS244 220.0V 200MIOA
D604	7043654016	1	PC	D-SLP 1N4148 100.0V 150E-3A
D605	7043654016	1	PC	D-SLP 1N4148 100.0V 150E-3A
D608	7043654016	1	PC	D-SLP 1N4148 100.0V 150E-3A
D701	7043654016	1	PC	D-SLP 1N4148 100.0V 150E-3A
D702	5523140016	1	PC	D-SLP 1SS244 220.0V 200MIOA
D703	5523140016	1	PC	D-SLP 1SS244 220.0V 200MIOA
D704	7043654016	1	PC	D-SLP 1N4148 100.0V 150E-3A
D705	7043654016	1	PC	D-SLP 1N4148 100.0V 150E-3A
D708	7043654016	1	PC	D-SLP 1N4148 100.0V 150E-3A
D801	7043654016	1	PC	D-SLP 1N4148 100.0V 150E-3A
D802	7043654016	1	PC	D-SLP 1N4148 100.0V 150E-3A
<i>Resistors</i>				
R430	55232760NR	1	PC	RMF 56R0 OHM +5% 1.0W
R431	55232760NR	1	PC	RMF 56R0 OHM +5% 1.0W
R438	55232750NR	1	PC	RMF 2R2 OHM +5% 1.0W
R439	55232750NR	1	PC	RMF 2R2 OHM +5% 1.0W
R461	1502271016	1	PC	RMOF 10R0 OHM +5% 2.0W
R471	55307540NR	1	PC	RW 270MIO OHM +5% 5.0W 100PPM/C -100PPM/C
R472	55307540NR	1	PC	RW 270MIO OHM +5% 5.0W 100PPM/C -100PPM/C
R530	55232760NR	1	PC	RMF 56R0 OHM +5% 1.0W
R531	55232760NR	1	PC	RMF 56R0 OHM +5% 1.0W

Ref Designator	Part Number	Qty		Description
4 CHANNEL AMP				
R538	55232750NR	1	PC	RMF 2R2 OHM +5% 1.0W
R539	55232750NR	1	PC	RMF 2R2 OHM +5% 1.0W
R561	1502271016	1	PC	RMOF 10R0 OHM +5% 2.0W
R571	55307540NR	1	PC	RW 270MIO OHM +5% 5.0W 100PPM/C -100PPM/C
R572	55307540NR	1	PC	RW 270MIO OHM +5% 5.0W 100PPM/C -100PPM/C
R630	55232760NR	1	PC	RMF 56R0 OHM +5% 1.0W
R631	55232760NR	1	PC	RMF 56R0 OHM +5% 1.0W
R638	55232750NR	1	PC	RMF 2R2 OHM +5% 1.0W
R639	55232750NR	1	PC	RMF 2R2 OHM +5% 1.0W
R661	1502271016	1	PC	RMOF 10R0 OHM +5% 2.0W
R671	55307540NR	1	PC	RW 270MIO OHM +5% 5.0W 100PPM/C -100PPM/C
R672	55307540NR	1	PC	RW 270MIO OHM +5% 5.0W 100PPM/C -100PPM/C
R730	55232760NR	1	PC	RMF 56R0 OHM +5% 1.0W
R731	55232760NR	1	PC	RMF 56R0 OHM +5% 1.0W
R738	55232750NR	1	PC	RMF 2R2 OHM +5% 1.0W
R739	55232750NR	1	PC	RMF 2R2 OHM +5% 1.0W
R761	1502271016	1	PC	RMOF 10R0 OHM +5% 2.0W
R771	55307540NR	1	PC	RW 270MIO OHM +5% 5.0W 100PPM/C -100PPM/C
R772	55307540NR	1	PC	RW 270MIO OHM +5% 5.0W 100PPM/C -100PPM/C
VR41	55250310NR	1	PC	PR 50R0 OHM +20% 500MIOW
VR42	55250320NR	1	PC	PR 200R0 OHM +20% 500MIOW
VR51	55250310NR	1	PC	PR 50R0 OHM +20% 500MIOW
VR52	55250320	1	PC	PR 200R0 OHM +20% 500MIOW
VR61	55250310NR	1	PC	PR 50R0 OHM +20% 500MIOW
VR62	55250320NR	1	PC	PR 200R0 OHM +20% 500MIOW
VR71	55250310NR	1	PC	PR 50R0 OHM +20% 500MIOW
VR72	55250320NR	1	PC	PR 200R0 OHM +20% 500MIOW
R401	1105964016	1	PC	RCF 1K0 OHM +5% 250MIOW
R402	5523153016	1	PC	RMF 33K0 OHM +1% 125MIOW +100PPM/C
R403	4043563016	1	PC	RCF 1K5 OHM +5% 250MIOW
R404	4043563016	1	PC	RCF 1K5 OHM +5% 250MIOW
R405	5088297016	1	PC	RCF 470R0 OHM +5% 250MIOW
R406	5088295016	1	PC	RCF 100R0 OHM +5% 250MIOW
R407	5088295016	1	PC	RCF 100R0 OHM +5% 250MIOW
R408	5088295016	1	PC	RCF 100R0 OHM +5% 250MIOW
R409	2046945016	1	PC	RCF 220R0 OHM +5% 250MIOW
R410	5523280016	1	PC	RMF 82R0 OHM +5% 500MIOW
R411	5523153016	1	PC	RMF 33K0 OHM +1% 125MIOW +100PPM/C
R412	1106089016	1	PC	RMF 2K43 OHM +1% 250MIOW
R413	1501565016	1	PC	RMF 2K67 OHM +1% 250MIOW
R414	6044156016	1	PC	RCF 560R0 OHM +5% 250MIOW
R415	6044156016	1	PC	RCF 560R0 OHM +5% 250MIOW
R416	6044156016	1	PC	RCF 560R0 OHM +5% 250MIOW
R417	6044156016	1	PC	RCF 560R0 OHM +5% 250MIOW
R418	6044156016	1	PC	RCF 560R0 OHM +5% 250MIOW
R419	6044156016	1	PC	RCF 560R0 OHM +5% 250MIOW
R420	5088296016	1	PC	RCF 150R0 OHM +5% 250MIOW
R421	5088296016	1	PC	RCF 150R0 OHM +5% 250MIOW
R422	5088296016	1	PC	RCF 150R0 OHM +5% 250MIOW
R423	5088296016	1	PC	RCF 150R0 OHM +5% 250MIOW
R424	5088301016	1	PC	RCF 15K0 OHM +5% 250MIOW
R425	5088301016	1	PC	RCF 15K0 OHM +5% 250MIOW
R426	2046946016	1	PC	RCF 2K2 OHM +5% 250MIOW
R429	8043698016	1	PC	RCF 620R0 OHM +5% 250MIOW
R432	5523277016	1	PC	RMF 2R2 OHM +5% 500MIOW
R433	5523277016	1	PC	RMF 2R2 OHM +5% 500MIOW
R434	5523278016	1	PC	RMF 100R0 OHM +5% 500MIOW
R435	5523278016	1	PC	RMF 100R0 OHM +5% 500MIOW
R436	5523279016	1	PC	RMF 15R0 OHM +5% 500MIOW
R437	5523279016	1	PC	RMF 15R0 OHM +5% 500MIOW
R440	5523281016	1	PC	RMF 10R0 OHM +5% 500MIOW
R441	5523281016	1	PC	RMF 10R0 OHM +5% 500MIOW
R442	5523281016	1	PC	RMF 10R0 OHM +5% 500MIOW
R443	5523281016	1	PC	RMF 10R0 OHM +5% 500MIOW
R444	8043700016	1	PC	RCF 1K2 OHM +5% 250MIOW
R445	8043700016	1	PC	RCF 1K2 OHM +5% 250MIOW
R446	5088301016	1	PC	RCF 15K0 OHM +5% 250MIOW

Ref Designator	Part Number	Qty		Description
4 CHANNEL AMP				
R447	2046949016	1	PC	RCF 6K8 OHM +5% 250MIOW
R448	3093938016	1	PC	RCF 22R0 OHM +5% 250MIOW
R449	3093938016	1	PC	RCF 22R0 OHM +5% 250MIOW
R450	3093949016	1	PC	RCF 33K0 OHM +5% 250MIOW
R455	4043567016	1	PC	RCF 47K0 OHM +5% 250MIOW
R456	2046946016	1	PC	RCF 2K2 OHM +5% 250MIOW
R457	1105958016	1	PC	RCF 56R0 OHM +5% 250MIOW
R470	4043567016	1	PC	RCF 47K0 OHM +5% 250MIOW
R501	1105964016	1	PC	RCF 1K0 OHM +5% 250MIOW
R502	5523153016	1	PC	RMF 33K0 OHM +1% 125MIOW +100PPM/C
R503	4043563016	1	PC	RCF 1K5 OHM +5% 250MIOW
R504	4043563016	1	PC	RCF 1K5 OHM +5% 250MIOW
R505	5088297016	1	PC	RCF 470R0 OHM +5% 250MIOW
R506	5088295016	1	PC	RCF 100R0 OHM +5% 250MIOW
R507	5088295016	1	PC	RCF 100R0 OHM +5% 250MIOW
R508	5088295016	1	PC	RCF 100R0 OHM +5% 250MIOW
R509	2046945016	1	PC	RCF 220R0 OHM +5% 250MIOW
R510	5523280016	1	PC	RMF 82R0 OHM +5% 500MIOW
R511	5523153016	1	PC	RMF 33K0 OHM +1% 125MIOW +100PPM/C
R512	1106089016	1	PC	RMF 2K43 OHM +1% 250MIOW
R513	1501565016	1	PC	RMF 2K67 OHM +1% 250MIOW
R514	6044156016	1	PC	RCF 560R0 OHM +5% 250MIOW
R515	6044156016	1	PC	RCF 560R0 OHM +5% 250MIOW
R516	6044156016	1	PC	RCF 560R0 OHM +5% 250MIOW
R517	6044156016	1	PC	RCF 560R0 OHM +5% 250MIOW
R518	6044156016	1	PC	RCF 560R0 OHM +5% 250MIOW
R519	6044156016	1	PC	RCF 560R0 OHM +5% 250MIOW
R520	5088296016	1	PC	RCF 150R0 OHM +5% 250MIOW
R521	5088296016	1	PC	RCF 150R0 OHM +5% 250MIOW
R522	5088296016	1	PC	RCF 150R0 OHM +5% 250MIOW
R523	5088296016	1	PC	RCF 150R0 OHM +5% 250MIOW
R524	5088301016	1	PC	RCF 15K0 OHM +5% 250MIOW
R525	5088301016	1	PC	RCF 15K0 OHM +5% 250MIOW
R526	2046946016	1	PC	RCF 2K2 OHM +5% 250MIOW
R529	8043698016	1	PC	RCF 620R0 OHM +5% 250MIOW
R532	5523277016	1	PC	RMF 2R2 OHM +5% 500MIOW
R533	5523277016	1	PC	RMF 2R2 OHM +5% 500MIOW
R534	5523278016	1	PC	RMF 100R0 OHM +5% 500MIOW
R535	5523278016	1	PC	RMF 100R0 OHM +5% 500MIOW
R536	5523279016	1	PC	RMF 15R0 OHM +5% 500MIOW
R537	5523279016	1	PC	RMF 15R0 OHM +5% 500MIOW
R540	5523281016	1	PC	RMF 10R0 OHM +5% 500MIOW
R541	5523281016	1	PC	RMF 10R0 OHM +5% 500MIOW
R542	5523281016	1	PC	RMF 10R0 OHM +5% 500MIOW
R543	5523281016	1	PC	RMF 10R0 OHM +5% 500MIOW
R544	8043700016	1	PC	RCF 1K2 OHM +5% 250MIOW
R545	8043700016	1	PC	RCF 1K2 OHM +5% 250MIOW
R546	5088301016	1	PC	RCF 15K0 OHM +5% 250MIOW
R547	2046949016	1	PC	RCF 6K8 OHM +5% 250MIOW
R548	3093938016	1	PC	RCF 22R0 OHM +5% 250MIOW
R549	3093938016	1	PC	RCF 22R0 OHM +5% 250MIOW
R550	3093949016	1	PC	RCF 33K0 OHM +5% 250MIOW
R555	4043567016	1	PC	RCF 47K0 OHM +5% 250MIOW
R556	2046946016	1	PC	RCF 2K2 OHM +5% 250MIOW
R557	1105958016	1	PC	RCF 56R0 OHM +5% 250MIOW
R570	4043567016	1	PC	RCF 47K0 OHM +5% 250MIOW
R601	1105964016	1	PC	RCF 1K0 OHM +5% 250MIOW
R602	5523153016	1	PC	RMF 33K0 OHM +1% 125MIOW +100PPM/C
R603	4043563016	1	PC	RCF 1K5 OHM +5% 250MIOW
R604	4043563016	1	PC	RCF 1K5 OHM +5% 250MIOW
R605	5088297016	1	PC	RCF 470R0 OHM +5% 250MIOW
R606	5088295016	1	PC	RCF 100R0 OHM +5% 250MIOW
R607	5088295016	1	PC	RCF 100R0 OHM +5% 250MIOW
R608	5088295016	1	PC	RCF 100R0 OHM +5% 250MIOW
R609	2046945016	1	PC	RCF 220R0 OHM +5% 250MIOW
R610	5523280016	1	PC	RMF 82R0 OHM +5% 500MIOW
R611	5523153016	1	PC	RMF 33K0 OHM +1% 125MIOW +100PPM/C

Ref Designator	Part Number	Qty		Description
4 CHANNEL AMP				
R612	1106089016	1	PC	RMF 2K43 OHM +1% 250MIOW
R613	1501565016	1	PC	RMF 2K67 OHM +1% 250MIOW
R614	6044156016	1	PC	RCF 560R0 OHM +5% 250MIOW
R615	6044156016	1	PC	RCF 560R0 OHM +5% 250MIOW
R616	6044156016	1	PC	RCF 560R0 OHM +5% 250MIOW
R617	6044156016	1	PC	RCF 560R0 OHM +5% 250MIOW
R618	6044156016	1	PC	RCF 560R0 OHM +5% 250MIOW
R619	6044156016	1	PC	RCF 560R0 OHM +5% 250MIOW
R620	5088296016	1	PC	RCF 150R0 OHM +5% 250MIOW
R621	5088296016	1	PC	RCF 150R0 OHM +5% 250MIOW
R622	5088296016	1	PC	RCF 150R0 OHM +5% 250MIOW
R623	5088296016	1	PC	RCF 150R0 OHM +5% 250MIOW
R624	5088301016	1	PC	RCF 15K0 OHM +5% 250MIOW
R625	5088301016	1	PC	RCF 15K0 OHM +5% 250MIOW
R626	2046946016	1	PC	RCF 2K2 OHM +5% 250MIOW
R629	8043698016	1	PC	RCF 620R0 OHM +5% 250MIOW
R632	5523277016	1	PC	RMF 2R2 OHM +5% 500MIOW
R633	5523277016	1	PC	RMF 2R2 OHM +5% 500MIOW
R634	5523278016	1	PC	RMF 100R0 OHM +5% 500MIOW
R635	5523278016	1	PC	RMF 100R0 OHM +5% 500MIOW
R636	5523279016	1	PC	RMF 15R0 OHM +5% 500MIOW
R637	5523279016	1	PC	RMF 15R0 OHM +5% 500MIOW
R640	5523281016	1	PC	RMF 10R0 OHM +5% 500MIOW
R641	5523281016	1	PC	RMF 10R0 OHM +5% 500MIOW
R642	5523281016	1	PC	RMF 10R0 OHM +5% 500MIOW
R643	5523281016	1	PC	RMF 10R0 OHM +5% 500MIOW
R644	8043700016	1	PC	RCF 1K2 OHM +5% 250MIOW
R645	8043700016	1	PC	RCF 1K2 OHM +5% 250MIOW
R646	5088301016	1	PC	RCF 15K0 OHM +5% 250MIOW
R647	2046949016	1	PC	RCF 6K8 OHM +5% 250MIOW
R648	3093938016	1	PC	RCF 22R0 OHM +5% 250MIOW
R649	3093938016	1	PC	RCF 22R0 OHM +5% 250MIOW
R650	3093949016	1	PC	RCF 33K0 OHM +5% 250MIOW
R655	4043567016	1	PC	RCF 47K0 OHM +5% 250MIOW
R656	2046946016	1	PC	RCF 2K2 OHM +5% 250MIOW
R657	1105958016	1	PC	RCF 56R0 OHM +5% 250MIOW
R670	4043567016	1	PC	RCF 47K0 OHM +5% 250MIOW
R701	1105964016	1	PC	RCF 1K0 OHM +5% 250MIOW
R702	5523153016	1	PC	RMF 33K0 OHM +1% 125MIOW +100PPM/C
R703	4043563016	1	PC	RCF 1K5 OHM +5% 250MIOW
R704	4043563016	1	PC	RCF 1K5 OHM +5% 250MIOW
R705	5088297016	1	PC	RCF 470R0 OHM +5% 250MIOW
R706	5088295016	1	PC	RCF 100R0 OHM +5% 250MIOW
R707	5088295016	1	PC	RCF 100R0 OHM +5% 250MIOW
R708	5088295016	1	PC	RCF 100R0 OHM +5% 250MIOW
R709	2046945016	1	PC	RCF 220R0 OHM +5% 250MIOW
R710	5523280016	1	PC	RMF 82R0 OHM +5% 500MIOW
R711	5523153016	1	PC	RMF 33K0 OHM +1% 125MIOW +100PPM/C
R712	1106089016	1	PC	RMF 2K43 OHM +1% 250MIOW
R713	1501565016	1	PC	RMF 2K67 OHM +1% 250MIOW
R714	6044156016	1	PC	RCF 560R0 OHM +5% 250MIOW
R715	6044156016	1	PC	RCF 560R0 OHM +5% 250MIOW
R716	6044156016	1	PC	RCF 560R0 OHM +5% 250MIOW
R717	6044156016	1	PC	RCF 560R0 OHM +5% 250MIOW
R718	6044156016	1	PC	RCF 560R0 OHM +5% 250MIOW
R719	6044156016	1	PC	RCF 560R0 OHM +5% 250MIOW
R720	5088296016	1	PC	RCF 150R0 OHM +5% 250MIOW
R721	5088296016	1	PC	RCF 150R0 OHM +5% 250MIOW
R722	5088296016	1	PC	RCF 150R0 OHM +5% 250MIOW
R723	5088296016	1	PC	RCF 150R0 OHM +5% 250MIOW
R724	5088301016	1	PC	RCF 15K0 OHM +5% 250MIOW
R725	5088301016	1	PC	RCF 15K0 OHM +5% 250MIOW
R726	2046946016	1	PC	RCF 2K2 OHM +5% 250MIOW
R729	8043698016	1	PC	RCF 620R0 OHM +5% 250MIOW
R732	5523277016	1	PC	RMF 2R2 OHM +5% 500MIOW
R733	5523277016	1	PC	RMF 2R2 OHM +5% 500MIOW
R734	5523278016	1	PC	RMF 100R0 OHM +5% 500MIOW

Ref Designator	Part Number	Qty		Description
4 CHANNEL AMP				
R735	5523278016	1	PC	RMF 100R0 OHM +5% 500MI0W
R736	5523279016	1	PC	RMF 15R0 OHM +5% 500MI0W
R737	5523279016	1	PC	RMF 15R0 OHM +5% 500MI0W
R740	5523281016	1	PC	RMF 10R0 OHM +5% 500MI0W
R741	5523281016	1	PC	RMF 10R0 OHM +5% 500MI0W
R742	5523281016	1	PC	RMF 10R0 OHM +5% 500MI0W
R743	5523281016	1	PC	RMF 10R0 OHM +5% 500MI0W
R744	8043700016	1	PC	RCF 1K2 OHM +5% 250MI0W
R745	8043700016	1	PC	RCF 1K2 OHM +5% 250MI0W
R746	5088301016	1	PC	RCF 15K0 OHM +5% 250MI0W
R747	2046949016	1	PC	RCF 6K8 OHM +5% 250MI0W
R748	3093938016	1	PC	RCF 22R0 OHM +5% 250MI0W
R749	3093938016	1	PC	RCF 22R0 OHM +5% 250MI0W
R750	3093949016	1	PC	RCF 33K0 OHM +5% 250MI0W
R755	4043567016	1	PC	RCF 47K0 OHM +5% 250MI0W
R756	2046946016	1	PC	RCF 2K2 OHM +5% 250MI0W
R757	1105958016	1	PC	RCF 56R0 OHM +5% 250MI0W
R770	4043567016	1	PC	RCF 47K0 OHM +5% 250MI0W
R801	6044154016	1	PC	RCF 180R0 OHM +5% 250MI0W
R802	4043567016	1	PC	RCF 47K0 OHM +5% 250MI0W
<i>Miscellaneous</i>				
B401	5517951018	1	PC	LFBEAD 44.1653OHM 100M0HZ FB-30 HC-3550
B402	5517951018	1	PC	LFBEAD 44.1653OHM 100M0HZ FB-30 HC-3550
B403	5517951018	1	PC	LFBEAD 44.1653OHM 100M0HZ FB-30 HC-3550
B404	5517951018	1	PC	LFBEAD 44.1653OHM 100M0HZ FB-30 HC-3550
B501	5517951018	1	PC	LFBEAD 44.1653OHM 100M0HZ FB-30 HC-3550
B502	5517951018	1	PC	LFBEAD 44.1653OHM 100M0HZ FB-30 HC-3550
B503	5517951018	1	PC	LFBEAD 44.1653OHM 100M0HZ FB-30 HC-3550
B504	5517951018	1	PC	LFBEAD 44.1653OHM 100M0HZ FB-30 HC-3550
B601	5517951018	1	PC	LFBEAD 44.1653OHM 100M0HZ FB-30 HC-3550
B602	5517951018	1	PC	LFBEAD 44.1653OHM 100M0HZ FB-30 HC-3550
B603	5517951018	1	PC	LFBEAD 44.1653OHM 100M0HZ FB-30 HC-3550
B604	5517951018	1	PC	LFBEAD 44.1653OHM 100M0HZ FB-30 HC-3550
B701	5517951018	1	PC	LFBEAD 44.1653OHM 100M0HZ FB-30 HC-3550
B702	5517951018	1	PC	LFBEAD 44.1653OHM 100M0HZ FB-30 HC-3550
B703	5517951018	1	PC	LFBEAD 44.1653OHM 100M0HZ FB-30 HC-3550
B704	5517951018	1	PC	LFBEAD 44.1653OHM 100M0HZ FB-30 HC-3550
G401	55135980NR	1	PC	TERMLUG GND
G501	55135980NR	1	PC	TERMLUG GND
G601	55135980NR	1	PC	TERMLUG GND
G701	55135980NR	1	PC	TERMLUG GND
G802	55135980NR	1	PC	TERMLUG GND
G803	55135980NR	1	PC	TERMLUG GND
L401	55179560NR	1	PC	LFA 1MM 10MM 5 LEFT 0.0MM NONE
L501	55179560NR	1	PC	LFA 1MM 10MM 5 LEFT 0.0MM NONE
L601	55179560NR	1	PC	LFA 1MM 10MM 5 LEFT 0.0MM NONE
L701	55179560NR	1	PC	LFA 1MM 10MM 5 LEFT 0.0MM NONE
N401	557207200	1	PC	WIRECONASY UNIQUE 6 260MM UL1007 RIBBON 24 1
N403	556868500	1	PC	WIRECONASY UNIQUE 2P 380MM UL1007 RIBBON 18 1
N501	556868100	1	PC	WIRECONASY UNIQUE 5P 150MM UL1007 RIBBON 24 1
N503	556868800	1	PC	WIRECONASY UNIQUE 2P 300MM UL1007 PVC DISCRETE 18 12
N601	556868900	1	PC	WIRECONASY UNIQUE 4P 180MM UL2547 24 12
N603	556869000	1	PC	WIRECONASY UNIQUE 2P 240MM UL1007 PVC DISCRETE 18 12
N701	556869100	1	PC	WIRECONASY UNIQUE 3P 250MM UL2547 24 12
N703	556869200	1	PC	WIRECONASY UNIQUE 2P 120MM UL1007 PVC DISCRETE 18 12
N801	556869300	1	PC	WIRECONASY UNIQUE 2P 170MM UL1007 PVC DISCRETE 18 12
N802	556869400	1	PC	WIRECONASY UNIQUE 2P 200MM UL1007 PVC DISCRETE 18 12
N803	556867700	1	PC	WIRECONASY UNIQUE 4P 180MM UL1007 PVC DISCRETE 16 1
N805	556867200	1	PC	WIRECONASY UNIQUE 2P 220MM UL1007 PVC DISCRETE 16 1
N905	555873900	1	PC	POS 100R0 OHM 16.0V
NJ41	55637150NR	1	PC	CONN-SPE SPEAKER TER'BOARD(2P) RD/BK D/N B30290111N
NJ51	55637160NR	1	PC	CONN-SPE SPEAKER TER'BOARD(2P) GY/BK D/N B30290115N

Ref Designator	Part Number	Qty		Description
4 CHANNEL AMP				
NJ61	55637210NR	1	PC	CONN-SPE SPEAKER TER'BOARD(4P) GN/BK/TAN/BK B30490163N
P401	55146560	1	PC	CONN 2.5MM 2 MA ST NAT 0 0
P402	55146570	1	PC	CONN 2.5MM 3 MA ST NAT 0 0
P406	55171540	1	PC	CONN 2.0MM 7 MA ST NAT MOLEX 35336-0710 0 0
P416	55171570	1	PC	CONN 2.0MM 7 MA R NAT BD'BD SOCKET MOLEX 35237-0710 0 0
P417	55171570	1	PC	CONN 2.0MM 7 MA R NAT BD'BD SOCKET MOLEX 35237-0710 0 0
P418	55171570	1	PC	CONN 2.0MM 7 MA R NAT BD'BD SOCKET MOLEX 35237-0710 0 0
P419	55171570	1	PC	CONN 2.0MM 7 MA R NAT BD'BD SOCKET MOLEX 35237-0710 0 0
P501	55146560	1	PC	CONN 2.5MM 2 MA ST NAT 0 0
P506	55171540	1	PC	CONN 2.0MM 7 MA ST NAT MOLEX 35336-0710 0 0
P601	55146560	1	PC	CONN 2.5MM 2 MA ST NAT 0 0
P606	55171540	1	PC	CONN 2.0MM 7 MA ST NAT MOLEX 35336-0710 0 0
P701	55146560	1	PC	CONN 2.5MM 2 MA ST NAT 0 0
P706	55171540	1	PC	CONN 2.0MM 7 MA ST NAT MOLEX 35336-0710 0 0
P802	55169140	1	PC	CON 3.96MM PITCH MOREX 35313-0210
P905	55146560	1	PC	CONN 2.5MM 2 MA ST NAT 0 0
SK41	55568280	1	PC	RELAYSGNL 24.0V 1K1OHM 5.0A
SK51	55568280	1	PC	RELAYSGNL 24.0V 1K1OHM 5.0A
SK61	55568280	1	PC	RELAYSGNL 24.0V 1K1OHM 5.0A
SK71	55568280	1	PC	RELAYSGNL 24.0V 1K1OHM 5.0A
W401	556870600	1	PC	WIRESSTRINS 4.0 CU WIRE 70MM BK 80C Y
W402	556870600	1	PC	WIRESSTRINS 4.0 CU WIRE 70MM BK 80C Y
W403	556870600	1	PC	WIRESSTRINS 4.0 CU WIRE 70MM BK 80C Y
W404	556870600	1	PC	WIRESSTRINS 4.0 CU WIRE 70MM BK 80C Y
W405	556870600	1	PC	WIRESSTRINS 4.0 CU WIRE 70MM BK 80C Y
W406	556870600	1	PC	WIRESSTRINS 4.0 CU WIRE 70MM BK 80C Y
DSP PCB				
<i>Capacitors</i>				
C103	2034206039	1	PC	CE 47U0F +20% 16.0V 85C
C107	2034206039	1	PC	CE 47U0F +20% 16.0V 85C
C108	2034206039	1	PC	CE 47U0F +20% 16.0V 85C
C109	2034206039	1	PC	CE 47U0F +20% 16.0V 85C
C146	2034206039	1	PC	CE 47U0F +20% 16.0V 85C
C147	2034206039	1	PC	CE 47U0F +20% 16.0V 85C
C148	2034206039	1	PC	CE 47U0F +20% 16.0V 85C
C149	2034206039	1	PC	CE 47U0F +20% 16.0V 85C
C194	2034206039	1	PC	CE 47U0F +20% 16.0V 85C
C231	20269180AM	1	PC	CE 1M10F +20% 6.3V 85C
C239	20269180AM	1	PC	CE 1M10F +20% 6.3V 85C
C240	20269180AM	1	PC	CE 1M10F +20% 6.3V 85C
C999	2050657091	1	PC	CCCFMIC 47P0F +5% -5% 50.0V NP0
C117	2028804091	1	PC	CCCFMIC 100N0F +80% -20% 16.0V Y5V
C199	2028804091	1	PC	CCCFMIC 100N0F +80% -20% 16.0V Y5V
C232	2028804091	1	PC	CCCFMIC 100N0F +80% -20% 16.0V Y5V
C286	2028804091	1	PC	CCCFMIC 100N0F +80% -20% 16.0V Y5V
C288	2028804091	1	PC	CCCFMIC 100N0F +80% -20% 16.0V Y5V
C289	2028804091	1	PC	CCCFMIC 100N0F +80% -20% 16.0V Y5V
C290	2028804091	1	PC	CCCFMIC 100N0F +80% -20% 16.0V Y5V
C291	2028804091	1	PC	CCCFMIC 100N0F +80% -20% 16.0V Y5V
C292	2028804091	1	PC	CCCFMIC 100N0F +80% -20% 16.0V Y5V
C293	2028804091	1	PC	CCCFMIC 100N0F +80% -20% 16.0V Y5V
C294	2028804091	1	PC	CCCFMIC 100N0F +80% -20% 16.0V Y5V
C295	2028804091	1	PC	CCCFMIC 100N0F +80% -20% 16.0V Y5V
C296	2028804091	1	PC	CCCFMIC 100N0F +80% -20% 16.0V Y5V
C297	2028804091	1	PC	CCCFMIC 100N0F +80% -20% 16.0V Y5V
C298	2028804091	1	PC	CCCFMIC 100N0F +80% -20% 16.0V Y5V
C299	2028804091	1	PC	CCCFMIC 100N0F +80% -20% 16.0V Y5V
C300	2028804091	1	PC	CCCFMIC 100N0F +80% -20% 16.0V Y5V
C301	2028804091	1	PC	CCCFMIC 100N0F +80% -20% 16.0V Y5V
C302	2028804091	1	PC	CCCFMIC 100N0F +80% -20% 16.0V Y5V
C303	2028804091	1	PC	CCCFMIC 100N0F +80% -20% 16.0V Y5V
C304	2028804091	1	PC	CCCFMIC 100N0F +80% -20% 16.0V Y5V

Ref Designator	Part Number	Qty		Description
DSP PCB				
C305	2028804091	1	PC	CCCFMIC 100N0F +80% -20% 16.0V Y5V
C306	2028804091	1	PC	CCCFMIC 100N0F +80% -20% 16.0V Y5V
C307	2028804091	1	PC	CCCFMIC 100N0F +80% -20% 16.0V Y5V
C308	2028804091	1	PC	CCCFMIC 100N0F +80% -20% 16.0V Y5V
C309	2028804091	1	PC	CCCFMIC 100N0F +80% -20% 16.0V Y5V
C310	2028804091	1	PC	CCCFMIC 100N0F +80% -20% 16.0V Y5V
C311	2028804091	1	PC	CCCFMIC 100N0F +80% -20% 16.0V Y5V
C312	2028804091	1	PC	CCCFMIC 100N0F +80% -20% 16.0V Y5V
C313	2028804091	1	PC	CCCFMIC 100N0F +80% -20% 16.0V Y5V
C314	2028804091	1	PC	CCCFMIC 100N0F +80% -20% 16.0V Y5V
C315	2028804091	1	PC	CCCFMIC 100N0F +80% -20% 16.0V Y5V
C316	2028804091	1	PC	CCCFMIC 100N0F +80% -20% 16.0V Y5V
C317	2028804091	1	PC	CCCFMIC 100N0F +80% -20% 16.0V Y5V
C318	2028804091	1	PC	CCCFMIC 100N0F +80% -20% 16.0V Y5V
C319	2028804091	1	PC	CCCFMIC 100N0F +80% -20% 16.0V Y5V
C320	2028804091	1	PC	CCCFMIC 100N0F +80% -20% 16.0V Y5V
C321	2028804091	1	PC	CCCFMIC 100N0F +80% -20% 16.0V Y5V
C322	2028804091	1	PC	CCCFMIC 100N0F +80% -20% 16.0V Y5V
C323	2028804091	1	PC	CCCFMIC 100N0F +80% -20% 16.0V Y5V
C324	2028804091	1	PC	CCCFMIC 100N0F +80% -20% 16.0V Y5V
C325	2028804091	1	PC	CCCFMIC 100N0F +80% -20% 16.0V Y5V
C326	2028804091	1	PC	CCCFMIC 100N0F +80% -20% 16.0V Y5V
C327	2028804091	1	PC	CCCFMIC 100N0F +80% -20% 16.0V Y5V
C328	2028804091	1	PC	CCCFMIC 100N0F +80% -20% 16.0V Y5V
C329	2028804091	1	PC	CCCFMIC 100N0F +80% -20% 16.0V Y5V
C330	2028804091	1	PC	CCCFMIC 100N0F +80% -20% 16.0V Y5V
C331	2028804091	1	PC	CCCFMIC 100N0F +80% -20% 16.0V Y5V
C332	2028804091	1	PC	CCCFMIC 100N0F +80% -20% 16.0V Y5V
C333	2028804091	1	PC	CCCFMIC 100N0F +80% -20% 16.0V Y5V
C334	2028804091	1	PC	CCCFMIC 100N0F +80% -20% 16.0V Y5V
C335	2028804091	1	PC	CCCFMIC 100N0F +80% -20% 16.0V Y5V
C336	2028804091	1	PC	CCCFMIC 100N0F +80% -20% 16.0V Y5V
C337	2028804091	1	PC	CCCFMIC 100N0F +80% -20% 16.0V Y5V
C338	2028804091	1	PC	CCCFMIC 100N0F +80% -20% 16.0V Y5V
C339	2067807091	1	PC	CCCFMIC 330P0F +5% -5% 50.0V NP0
C340	2028804091	1	PC	CCCFMIC 100N0F +80% -20% 16.0V Y5V
C341	2028806091	1	PC	CCCFMIC 220N0F +80% -20% 16.0V Y5V
C342	2067807091	1	PC	CCCFMIC 330P0F +5% -5% 50.0V NP0
C343	2028804091	1	PC	CCCFMIC 100N0F +80% -20% 16.0V Y5V
C344	2028804091	1	PC	CCCFMIC 100N0F +80% -20% 16.0V Y5V
C345	2050664091	1	PC	CCCFMIC 220P0F +5% -5% 50.0V NP0
C346	2028804091	1	PC	CCCFMIC 100N0F +80% -20% 16.0V Y5V
C349	2028804091	1	PC	CCCFMIC 100N0F +80% -20% 16.0V Y5V
C350	2028804091	1	PC	CCCFMIC 100N0F +80% -20% 16.0V Y5V
C351	2028804091	1	PC	CCCFMIC 100N0F +80% -20% 16.0V Y5V
C352	2028804091	1	PC	CCCFMIC 100N0F +80% -20% 16.0V Y5V
C106	1012100039	1	PC	CE 10U0F +20% 16.0V 85C
C110	1012100039	1	PC	CE 10U0F +20% 16.0V 85C
C111	1012100039	1	PC	CE 10U0F +20% 16.0V 85C
C112	1012100039	1	PC	CE 10U0F +20% 16.0V 85C
C113	1012100039	1	PC	CE 10U0F +20% 16.0V 85C
C114	1012100039	1	PC	CE 10U0F +20% 16.0V 85C
C133	1012100039	1	PC	CE 10U0F +20% 16.0V 85C
C142	2026902030	1	PC	CE 100U0F +20% 16.0V 85C
C143	1012100039	1	PC	CE 10U0F +20% 16.0V 85C
C144	1012100039	1	PC	CE 10U0F +20% 16.0V 85C
C150	1012100039	1	PC	CE 10U0F +20% 16.0V 85C
C151	1012100039	1	PC	CE 10U0F +20% 16.0V 85C
C152	1012100039	1	PC	CE 10U0F +20% 16.0V 85C
C153	1012100039	1	PC	CE 10U0F +20% 16.0V 85C
C158	1012100039	1	PC	CE 10U0F +20% 16.0V 85C
C159	1024427039	1	PC	CE 100U0F +20% 16.0V 85C
C160	1024427039	1	PC	CE 100U0F +20% 16.0V 85C
C161	1012100039	1	PC	CE 10U0F +20% 16.0V 85C
C162	1012100039	1	PC	CE 10U0F +20% 16.0V 85C
C163	1012100039	1	PC	CE 10U0F +20% 16.0V 85C
C164	1012100039	1	PC	CE 10U0F +20% 16.0V 85C

Ref Designator	Part Number	Qty		Description
DSP PCB				
C165	2026902030	1	PC	CE 100U0F +20% 16.0V 85C
C168	1012100039	1	PC	CE 10U0F +20% 16.0V 85C
C172	1012100039	1	PC	CE 10U0F +20% 16.0V 85C
C175	1012100039	1	PC	CE 10U0F +20% 16.0V 85C
C178	1024427039	1	PC	CE 100U0F +20% 16.0V 85C
C187	1012100039	1	PC	CE 10U0F +20% 16.0V 85C
C200	1012100039	1	PC	CE 10U0F +20% 16.0V 85C
C204	1012100039	1	PC	CE 10U0F +20% 16.0V 85C
C207	1012100039	1	PC	CE 10U0F +20% 16.0V 85C
C208	1024427039	1	PC	CE 100U0F +20% 16.0V 85C
C209	1024427039	1	PC	CE 100U0F +20% 16.0V 85C
C210	1012100039	1	PC	CE 10U0F +20% 16.0V 85C
C211	1012100039	1	PC	CE 10U0F +20% 16.0V 85C
C212	1012100039	1	PC	CE 10U0F +20% 16.0V 85C
C213	1012100039	1	PC	CE 10U0F +20% 16.0V 85C
C214	1012100039	1	PC	CE 10U0F +20% 16.0V 85C
C215	1012100039	1	PC	CE 10U0F +20% 16.0V 85C
C216	1012100039	1	PC	CE 10U0F +20% 16.0V 85C
C217	1012100039	1	PC	CE 10U0F +20% 16.0V 85C
C221	1012100039	1	PC	CE 10U0F +20% 16.0V 85C
C222	1012100039	1	PC	CE 10U0F +20% 16.0V 85C
C229	1024427039	1	PC	CE 100U0F +20% 16.0V 85C
C234	1012100039	1	PC	CE 10U0F +20% 16.0V 85C
C242	1024427039	1	PC	CE 100U0F +20% 16.0V 85C
C243	1024427039	1	PC	CE 100U0F +20% 16.0V 85C
C244	1012100039	1	PC	CE 10U0F +20% 16.0V 85C
C248	1012100039	1	PC	CE 10U0F +20% 16.0V 85C
C253	1024427039	1	PC	CE 100U0F +20% 16.0V 85C
C256	1012100039	1	PC	CE 10U0F +20% 16.0V 85C
C262	1024427039	1	PC	CE 100U0F +20% 16.0V 85C
C263	1024427039	1	PC	CE 100U0F +20% 16.0V 85C
C268	1012100039	1	PC	CE 10U0F +20% 16.0V 85C
C273	1024427039	1	PC	CE 100U0F +20% 16.0V 85C
C274	1012100039	1	PC	CE 10U0F +20% 16.0V 85C
C278	1012100039	1	PC	CE 10U0F +20% 16.0V 85C
C279	2026885039	1	PC	CE 2U2F +20% 50.0V 85C
C281	2026883039	1	PC	CE 470N0F +20% 50.0V 85C
C282	1012100039	1	PC	CE 10U0F +20% 16.0V 85C
C284	1012100039	1	PC	CE 10U0F +20% 16.0V 85C
C285	1024427039	1	PC	CE 100U0F +20% 16.0V 85C
C001	1013896091	1	PC	CCCFMIC 10N0F +10% -10% 50.0V X7R
C002	1013896091	1	PC	CCCFMIC 10N0F +10% -10% 50.0V X7R
C003	2050652091	1	PC	CCCFMIC 22P0F +5% -5% 50.0V NP0
C004	1013896091	1	PC	CCCFMIC 10N0F +10% -10% 50.0V X7R
C005	2028804091	1	PC	CCCFMIC 100N0F +80% -20% 16.0V Y5V
C104	2050659091	1	PC	CCCFMIC 100P0F +5% -5% 50.0V NP0
C105	2050659091	1	PC	CCCFMIC 100P0F +5% -5% 50.0V NP0
C115	2050659091	1	PC	CCCFMIC 100P0F +5% -5% 50.0V NP0
C116	2050659091	1	PC	CCCFMIC 100P0F +5% -5% 50.0V NP0
C118	1105871091	1	PC	CCCFMIN 560P0F +5% -5% 50.0V NP0
C119	1105871091	1	PC	CCCFMIN 560P0F +5% -5% 50.0V NP0
C120	1105871091	1	PC	CCCFMIN 560P0F +5% -5% 50.0V NP0
C121	1105871091	1	PC	CCCFMIN 560P0F +5% -5% 50.0V NP0
C122	1013839091	1	PC	CCCFMIC 560P0F +10% -10% 50.0V X7R
C123	1013839091	1	PC	CCCFMIC 560P0F +10% -10% 50.0V X7R
C124	1105871091	1	PC	CCCFMIN 560P0F +5% -5% 50.0V NP0
C125	1105871091	1	PC	CCCFMIN 560P0F +5% -5% 50.0V NP0
C126	1105871091	1	PC	CCCFMIN 560P0F +5% -5% 50.0V NP0
C127	1105871091	1	PC	CCCFMIN 560P0F +5% -5% 50.0V NP0
C131	2050659091	1	PC	CCCFMIC 100P0F +5% -5% 50.0V NP0
C132	2050659091	1	PC	CCCFMIC 100P0F +5% -5% 50.0V NP0
C134	1013863091	1	PC	CCCFMIC 2N7F +10% -10% 50.0V X7R
C135	1013863091	1	PC	CCCFMIC 2N7F +10% -10% 50.0V X7R
C136	1013863091	1	PC	CCCFMIC 2N7F +10% -10% 50.0V X7R
C137	1013863091	1	PC	CCCFMIC 2N7F +10% -10% 50.0V X7R
C138	1013863091	1	PC	CCCFMIC 2N7F +10% -10% 50.0V X7R
C139	1013863091	1	PC	CCCFMIC 2N7F +10% -10% 50.0V X7R

Ref Designator	Part Number	Qty		Description
DSP PCB				
C140	1013863091	1	PC	CCCFMIC 2N7F +10% -10% 50.0V X7R
C141	1013863091	1	PC	CCCFMIC 2N7F +10% -10% 50.0V X7R
C145	2050659091	1	PC	CCCFMIC 100P0F +5% -5% 50.0V NP0
C154	2050659091	1	PC	CCCFMIC 100P0F +5% -5% 50.0V NP0
C155	2050659091	1	PC	CCCFMIC 100P0F +5% -5% 50.0V NP0
C156	2050659091	1	PC	CCCFMIC 100P0F +5% -5% 50.0V NP0
C157	1013855091	1	PC	CCCFMIC 1N0F +10% -10% 50.0V X7R
C166	2050659091	1	PC	CCCFMIC 100P0F +5% -5% 50.0V NP0
C167	2050659091	1	PC	CCCFMIC 100P0F +5% -5% 50.0V NP0
C169	2050659091	1	PC	CCCFMIC 100P0F +5% -5% 50.0V NP0
C170	2028804091	1	PC	CCCFMIC 100N0F +80% -20% 16.0V Y5V
C171	2028804091	1	PC	CCCFMIC 100N0F +80% -20% 16.0V Y5V
C173	2028804091	1	PC	CCCFMIC 100N0F +80% -20% 16.0V Y5V
C174	2028804091	1	PC	CCCFMIC 100N0F +80% -20% 16.0V Y5V
C176	2050659091	1	PC	CCCFMIC 100P0F +5% -5% 50.0V NP0
C177	1013855091	1	PC	CCCFMIC 1N0F +10% -10% 50.0V X7R
C179	1105871091	1	PC	CCCFMIN 560P0F +5% -5% 50.0V NP0
C180	1105871091	1	PC	CCCFMIN 560P0F +5% -5% 50.0V NP0
C181	1105871091	1	PC	CCCFMIN 560P0F +5% -5% 50.0V NP0
C182	1105871091	1	PC	CCCFMIN 560P0F +5% -5% 50.0V NP0
C183	1105871091	1	PC	CCCFMIN 560P0F +5% -5% 50.0V NP0
C184	1105871091	1	PC	CCCFMIN 560P0F +5% -5% 50.0V NP0
C185	1105871091	1	PC	CCCFMIN 560P0F +5% -5% 50.0V NP0
C186	1105871091	1	PC	CCCFMIN 560P0F +5% -5% 50.0V NP0
C188	2050659091	1	PC	CCCFMIC 100P0F +5% -5% 50.0V NP0
C189	2050659091	1	PC	CCCFMIC 100P0F +5% -5% 50.0V NP0
C190	1013863091	1	PC	CCCFMIC 2N7F +10% -10% 50.0V X7R
C191	1013863091	1	PC	CCCFMIC 2N7F +10% -10% 50.0V X7R
C192	1013863091	1	PC	CCCFMIC 2N7F +10% -10% 50.0V X7R
C193	1013863091	1	PC	CCCFMIC 2N7F +10% -10% 50.0V X7R
C195	1013863091	1	PC	CCCFMIC 2N7F +10% -10% 50.0V X7R
C196	1013863091	1	PC	CCCFMIC 2N7F +10% -10% 50.0V X7R
C197	1013863091	1	PC	CCCFMIC 2N7F +10% -10% 50.0V X7R
C198	1013863091	1	PC	CCCFMIC 2N7F +10% -10% 50.0V X7R
C201	2050659091	1	PC	CCCFMIC 100P0F +5% -5% 50.0V NP0
C202	2050659091	1	PC	CCCFMIC 100P0F +5% -5% 50.0V NP0
C203	1013855091	1	PC	CCCFMIC 1N0F +10% -10% 50.0V X7R
C205	2050659091	1	PC	CCCFMIC 100P0F +5% -5% 50.0V NP0
C206	2050659091	1	PC	CCCFMIC 100P0F +5% -5% 50.0V NP0
C218	2050659091	1	PC	CCCFMIC 100P0F +5% -5% 50.0V NP0
C219	2028804091	1	PC	CCCFMIC 100N0F +80% -20% 16.0V Y5V
C220	2028804091	1	PC	CCCFMIC 100N0F +80% -20% 16.0V Y5V
C223	2050659091	1	PC	CCCFMIC 100P0F +5% -5% 50.0V NP0
C224	2050659091	1	PC	CCCFMIC 100P0F +5% -5% 50.0V NP0
C225	2050659091	1	PC	CCCFMIC 100P0F +5% -5% 50.0V NP0
C226	1013855091	1	PC	CCCFMIC 1N0F +10% -10% 50.0V X7R
C227	2028804091	1	PC	CCCFMIC 100N0F +80% -20% 16.0V Y5V
C228	2028804091	1	PC	CCCFMIC 100N0F +80% -20% 16.0V Y5V
C233	2050652091	1	PC	CCCFMIC 22P0F +5% -5% 50.0V NP0
C235	2050659091	1	PC	CCCFMIC 100P0F +5% -5% 50.0V NP0
C236	1013896091	1	PC	CCCFMIC 10N0F +10% -10% 50.0V X7R
C237	2050659091	1	PC	CCCFMIC 100P0F +5% -5% 50.0V NP0
C238	1013855091	1	PC	CCCFMIC 1N0F +10% -10% 50.0V X7R
C241	2028804091	1	PC	CCCFMIC 100N0F +80% -20% 16.0V Y5V
C245	2050659091	1	PC	CCCFMIC 100P0F +5% -5% 50.0V NP0
C246	2028804091	1	PC	CCCFMIC 100N0F +80% -20% 16.0V Y5V
C247	2028804091	1	PC	CCCFMIC 100N0F +80% -20% 16.0V Y5V
C249	2050659091	1	PC	CCCFMIC 100P0F +5% -5% 50.0V NP0
C250	1013855091	1	PC	CCCFMIC 1N0F +10% -10% 50.0V X7R
C251	2028804091	1	PC	CCCFMIC 100N0F +80% -20% 16.0V Y5V
C252	2028804091	1	PC	CCCFMIC 100N0F +80% -20% 16.0V Y5V
C254	2050652091	1	PC	CCCFMIC 22P0F +5% -5% 50.0V NP0
C255	1013896091	1	PC	CCCFMIC 10N0F +10% -10% 50.0V X7R
C257	2028804091	1	PC	CCCFMIC 100N0F +80% -20% 16.0V Y5V
C258	2028804091	1	PC	CCCFMIC 100N0F +80% -20% 16.0V Y5V
C259	2050659091	1	PC	CCCFMIC 100P0F +5% -5% 50.0V NP0
C260	2050659091	1	PC	CCCFMIC 100P0F +5% -5% 50.0V NP0

Ref Designator	Part Number	Qty		Description
DSP PCB				
C261	1013855091	1	PC	CCCFMIC 1N0F +10% -10% 50.0V X7R
C264	2050659091	1	PC	CCCFMIC 100P0F +5% -5% 50.0V NP0
C265	2028804091	1	PC	CCCFMIC 100N0F +80% -20% 16.0V Y5V
C266	2028804091	1	PC	CCCFMIC 100N0F +80% -20% 16.0V Y5V
C267	2028804091	1	PC	CCCFMIC 100N0F +80% -20% 16.0V Y5V
C269	2050659091	1	PC	CCCFMIC 100P0F +5% -5% 50.0V NP0
C270	1013855091	1	PC	CCCFMIC 1N0F +10% -10% 50.0V X7R
C271	2028804091	1	PC	CCCFMIC 100N0F +80% -20% 16.0V Y5V
C272	2028804091	1	PC	CCCFMIC 100N0F +80% -20% 16.0V Y5V
C275	2028804091	1	PC	CCCFMIC 100N0F +80% -20% 16.0V Y5V
C276	2028804091	1	PC	CCCFMIC 100N0F +80% -20% 16.0V Y5V
C280	2028804091	1	PC	CCCFMIC 100N0F +80% -20% 16.0V Y5V
C283	2028804091	1	PC	CCCFMIC 100N0F +80% -20% 16.0V Y5V
C347	2028804091	1	PC	CCCFMIC 100N0F +80% -20% 16.0V Y5V
C348	2028804091	1	PC	CCCFMIC 100N0F +80% -20% 16.0V Y5V
C401	2050654091	1	PC	CCCFMIC 10P0F +0P5F -0P5F 50.0V NP0
C901	1013896091	1	PC	CCCFMIC 10N0F +10% -10% 50.0V X7R
Semiconductors				
IC18	55142610MT	1	PC	IC-OPERAMP NJM2068M DUAL OP
IC19	55142610MT	1	PC	IC-OPERAMP NJM2068M DUAL OP
IC20	55142610MT	1	PC	IC-OPERAMP NJM2068M DUAL OP
IC21	55142610MT	1	PC	IC-OPERAMP NJM2068M DUAL OP
IC22	55142610MT	1	PC	IC-OPERAMP NJM2068M DUAL OP
IC23	55142610MT	1	PC	IC-OPERAMP NJM2068M DUAL OP
IC24	55142610MT	1	PC	IC-OPERAMP NJM2068M DUAL OP
IC25	55142610MT	1	PC	IC-OPERAMP NJM2068M DUAL OP
IC26	55142610MT	1	PC	IC-OPERAMP NJM2068M DUAL OP
IC27	55142610MT	1	PC	IC-OPERAMP NJM2068M DUAL OP
IC28	55125420MT	1	PC	IC-LOGIC 74VHC244MX INVERTER CMOS
IC29	55142610MT	1	PC	IC-OPERAMP NJM2068M DUAL OP
IC30	55142610MT	1	PC	IC-OPERAMP NJM2068M DUAL OP
IC31	55142610MT	1	PC	IC-OPERAMP NJM2068M DUAL OP
IC33	55170220MT	1	PC	IC-LOGIC F/F 74VHC574MX FLIP/FLOP HCMOS
IC34	55170220MT	1	PC	IC-LOGIC F/F 74VHC574MX FLIP/FLOP HCMOS
Q105	5513871092	1	PC	TR-SLPSWA KTD1304 N 20V 300MIOA
Q106	5513319092	1	PC	TR-SSD DTA114YKA P 10K0 OHM 47K0 OHM
Q901	5513329056	1	PC	TR-SLPLF KTD1302 B N 300MIOA 20V
Q902	5513322056	1	PC	TR-SLPLF DTA114YSA P 100MIOA
D100	2049651085	1	PC	D-SLP 1SS355 35.0V 225MIOA
D102	2049651085	1	PC	D-SLP 1SS355 35.0V 225MIOA
IC01	55204170MT	1	PC	IC-SWITCH NJU201AM ANALOG SWITCH
IC03	55142610MT	1	PC	IC-OPERAMP NJM2068M DUAL OP
IC04	55204160MU	1	PC	IC-CONV CS5360-KS A/D
IC05	55142610MT	1	PC	IC-OPERAMP NJM2068M DUAL OP
IC06	55451460MS	1	PC	IC-CONV CS4382-KQ 8CH D/A
IC07	55142610MT	1	PC	IC-OPERAMP NJM2068M DUAL OP
IC08	55204160MU	1	PC	IC-CONV CS5360-KS A/D
IC09	55133310MT	1	PC	IC-LOGIC M74HCU04M1R INVERTER HCT
IC10	55204160MU	1	PC	IC-CONV CS5360-KS A/D
IC11	55510180MS	1	PC	IC-ASIC M4A3-32-10VC-12VI COMPLEX PLD
IC12	55690020MS	1	PC	IC-MICROCONT CXP82860-385Q SUB AVR7200
IC13	55204160MU	1	PC	IC-CONV CS5360-KS A/D
IC14	55133310MT	1	PC	IC-LOGIC M74HCU04M1R INVERTER HCT
IC15	55157760KV	1	PC	IC-EPROM AT27LV040A-90JC
IC16	55476130MS	1	PC	IC-SPECFUNC AK4114VQ LQFP48 DIGITAL INTERFACE TRANS
IC17	5512538AMU	1	PC	IC-LOWFREQ CS493263-CL G VERSION DSP
IC35	55142610MT	1	PC	IC-OPERAMP NJM2068M DUAL OP
Q100	5513318092	1	PC	TR-SSD DTC114YKA N 10K0 OHM 47K0 OHM
Q101	5513318092	1	PC	TR-SSD DTC114YKA N 10K0 OHM 47K0 OHM
Q102	5513319092	1	PC	TR-SSD DTA114YKA P 10K0 OHM 47K0 OHM
Q103	5513871092	1	PC	TR-SLPSWA KTD1304 N 20V 300MIOA
Q104	5513318092	1	PC	TR-SSD DTC114YKA N 10K0 OHM 47K0 OHM

Ref Designator	Part Number	Qty		Description
DSP PCB				
<i>Resistors</i>				
R001	1013594091	1	PC	RMGCFMIC 4K7 OHM +5% 62MI5W
R002	1013594091	1	PC	RMGCFMIC 4K7 OHM +5% 62MI5W
R003	1013594091	1	PC	RMGCFMIC 4K7 OHM +5% 62MI5W
R015	1032875091	1	PC	RMGCFMIC 0 OHM +0% 62MI5W
R016	1013594091	1	PC	RMGCFMIC 4K7 OHM +5% 62MI5W
R017	1013594091	1	PC	RMGCFMIC 4K7 OHM +5% 62MI5W
R020	1032875091	1	PC	RMGCFMIC 0 OHM +0% 62MI5W
R021	1013594091	1	PC	RMGCFMIC 4K7 OHM +5% 62MI5W
R022	1013594091	1	PC	RMGCFMIC 4K7 OHM +5% 62MI5W
R276	1013501091	1	PC	RMGCFMIC 10K0 OHM +5% 62MI5W
R313	2074028091	1	PC	RMGCFMIC 3R3 OHM +5% 62MI5W
R314	2074028091	1	PC	RMGCFMIC 3R3 OHM +5% 62MI5W
R352	1013501091	1	PC	RMGCFMIC 10K0 OHM +5% 62MI5W
R353	1013441091	1	PC	RMGCFMIC 10R0 OHM +5% 62MI5W
R379	1013474091	1	PC	RMGCFMIC 100R0 OHM +5% 62MI5W
R380	1013478091	1	PC	RMGCFMIC 150R0 OHM +5% 62MI5W
R381	1013534091	1	PC	RMGCFMIC 100K0 OHM +5% 62MI5W
R382	1013534091	1	PC	RMGCFMIC 100K0 OHM +5% 62MI5W
R385	1013534091	1	PC	RMGCFMIC 100K0 OHM +5% 62MI5W
R386	1013474091	1	PC	RMGCFMIC 100R0 OHM +5% 62MI5W
R387	1013534091	1	PC	RMGCFMIC 100K0 OHM +5% 62MI5W
R388	1013478091	1	PC	RMGCFMIC 150R0 OHM +5% 62MI5W
R389	1013478091	1	PC	RMGCFMIC 150R0 OHM +5% 62MI5W
R390	1013534091	1	PC	RMGCFMIC 100K0 OHM +5% 62MI5W
R391	1013534091	1	PC	RMGCFMIC 100K0 OHM +5% 62MI5W
R392	1013534091	1	PC	RMGCFMIC 100K0 OHM +5% 62MI5W
R393	1013534091	1	PC	RMGCFMIC 100K0 OHM +5% 62MI5W
R394	1013478091	1	PC	RMGCFMIC 150R0 OHM +5% 62MI5W
R396	1013594091	1	PC	RMGCFMIC 4K7 OHM +5% 62MI5W
R397	1013478091	1	PC	RMGCFMIC 150R0 OHM +5% 62MI5W
R398	1013594091	1	PC	RMGCFMIC 4K7 OHM +5% 62MI5W
R399	1013534091	1	PC	RMGCFMIC 100K0 OHM +5% 62MI5W
R400	1013534091	1	PC	RMGCFMIC 100K0 OHM +5% 62MI5W
R401	1013534091	1	PC	RMGCFMIC 100K0 OHM +5% 62MI5W
R402	1013534091	1	PC	RMGCFMIC 100K0 OHM +5% 62MI5W
R403	1013478091	1	PC	RMGCFMIC 150R0 OHM +5% 62MI5W
R404	1013478091	1	PC	RMGCFMIC 150R0 OHM +5% 62MI5W
R405	1013594091	1	PC	RMGCFMIC 4K7 OHM +5% 62MI5W
R407	1013534091	1	PC	RMGCFMIC 100K0 OHM +5% 62MI5W
R408	1013534091	1	PC	RMGCFMIC 100K0 OHM +5% 62MI5W
R409	1013594091	1	PC	RMGCFMIC 4K7 OHM +5% 62MI5W
R410	1013534091	1	PC	RMGCFMIC 100K0 OHM +5% 62MI5W
R411	1013534091	1	PC	RMGCFMIC 100K0 OHM +5% 62MI5W
R412	1013478091	1	PC	RMGCFMIC 150R0 OHM +5% 62MI5W
R413	1013594091	1	PC	RMGCFMIC 4K7 OHM +5% 62MI5W
R415	1013594091	1	PC	RMGCFMIC 4K7 OHM +5% 62MI5W
R416	1013594091	1	PC	RMGCFMIC 4K7 OHM +5% 62MI5W
R418	1013594091	1	PC	RMGCFMIC 4K7 OHM +5% 62MI5W
R421	1013590091	1	PC	RMGCFMIC 3K3 OHM +5% 62MI5W
R422	1013590091	1	PC	RMGCFMIC 3K3 OHM +5% 62MI5W
R423	1013501091	1	PC	RMGCFMIC 10K0 OHM +5% 62MI5W
R424	1013508091	1	PC	RMGCFMIC 18K0 OHM +5% 62MI5W
R428	1013501091	1	PC	RMGCFMIC 10K0 OHM +5% 62MI5W
R429	1013594091	1	PC	RMGCFMIC 4K7 OHM +5% 62MI5W
R430	1013590091	1	PC	RMGCFMIC 3K3 OHM +5% 62MI5W
R431	1013501091	1	PC	RMGCFMIC 10K0 OHM +5% 62MI5W
R432	1013501091	1	PC	RMGCFMIC 10K0 OHM +5% 62MI5W
R433	1013590091	1	PC	RMGCFMIC 3K3 OHM +5% 62MI5W
R907	1013483091	1	PC	RMGCFMIC 220R0 OHM +5% 62MI5W
R004	1013594091	1	PC	RMGCFMIC 4K7 OHM +5% 62MI5W
R005	1013594091	1	PC	RMGCFMIC 4K7 OHM +5% 62MI5W
R006	1013594091	1	PC	RMGCFMIC 4K7 OHM +5% 62MI5W
R007	1013594091	1	PC	RMGCFMIC 4K7 OHM +5% 62MI5W
R008	1013594091	1	PC	RMGCFMIC 4K7 OHM +5% 62MI5W
R009	1013594091	1	PC	RMGCFMIC 4K7 OHM +5% 62MI5W

Ref Designator	Part Number	Qty		Description
DSP PCB				
R011	1013522091	1	PC	RMGCFMIC 47K0 OHM +5% 62MI5W
R012	1013493091	1	PC	RMGCFMIC 560R0 OHM +5% 62MI5W
R013	1032875091	1	PC	RMGCFMIC 0 OHM +0% 62MI5W
R10	1013471091	1	PC	RMGCFMIC 75R0 OHM +5% 62MI5W
R100	1013577091	1	PC	RMGCFMIC 1K0 OHM +5% 62MI5W
R101	1013577091	1	PC	RMGCFMIC 1K0 OHM +5% 62MI5W
R102	1013522091	1	PC	RMGCFMIC 47K0 OHM +5% 62MI5W
R103	1013534091	1	PC	RMGCFMIC 100K0 OHM +5% 62MI5W
R104	1013534091	1	PC	RMGCFMIC 100K0 OHM +5% 62MI5W
R105	1013534091	1	PC	RMGCFMIC 100K0 OHM +5% 62MI5W
R106	1013534091	1	PC	RMGCFMIC 100K0 OHM +5% 62MI5W
R107	1013534091	1	PC	RMGCFMIC 100K0 OHM +5% 62MI5W
R108	1013534091	1	PC	RMGCFMIC 100K0 OHM +5% 62MI5W
R109	1013577091	1	PC	RMGCFMIC 1K0 OHM +5% 62MI5W
R110	1013522091	1	PC	RMGCFMIC 47K0 OHM +5% 62MI5W
R111	1013577091	1	PC	RMGCFMIC 1K0 OHM +5% 62MI5W
R112	1013596091	1	PC	RMGCFMIC 5K6 OHM +5% 62MI5W
R113	1013596091	1	PC	RMGCFMIC 5K6 OHM +5% 62MI5W
R114	1013493091	1	PC	RMGCFMIC 560R0 OHM +5% 62MI5W
R115	1013493091	1	PC	RMGCFMIC 560R0 OHM +5% 62MI5W
R116	1013596091	1	PC	RMGCFMIC 5K6 OHM +5% 62MI5W
R117	1013596091	1	PC	RMGCFMIC 5K6 OHM +5% 62MI5W
R118	1013493091	1	PC	RMGCFMIC 560R0 OHM +5% 62MI5W
R119	1013579091	1	PC	RMGCFMIC 1K2 OHM +5% 62MI5W
R120	1013579091	1	PC	RMGCFMIC 1K2 OHM +5% 62MI5W
R121	1013493091	1	PC	RMGCFMIC 560R0 OHM +5% 62MI5W
R122	1013493091	1	PC	RMGCFMIC 560R0 OHM +5% 62MI5W
R123	1013579091	1	PC	RMGCFMIC 1K2 OHM +5% 62MI5W
R124	1013579091	1	PC	RMGCFMIC 1K2 OHM +5% 62MI5W
R125	1013493091	1	PC	RMGCFMIC 560R0 OHM +5% 62MI5W
R126	1013501091	1	PC	RMGCFMIC 10K0 OHM +5% 62MI5W
R127	1013501091	1	PC	RMGCFMIC 10K0 OHM +5% 62MI5W
R128	1013579091	1	PC	RMGCFMIC 1K2 OHM +5% 62MI5W
R129	1013577091	1	PC	RMGCFMIC 1K0 OHM +5% 62MI5W
R130	1013577091	1	PC	RMGCFMIC 1K0 OHM +5% 62MI5W
R131	1013579091	1	PC	RMGCFMIC 1K2 OHM +5% 62MI5W
R132	1013577091	1	PC	RMGCFMIC 1K0 OHM +5% 62MI5W
R133	1013579091	1	PC	RMGCFMIC 1K2 OHM +5% 62MI5W
R134	1013596091	1	PC	RMGCFMIC 5K6 OHM +5% 62MI5W
R135	1013596091	1	PC	RMGCFMIC 5K6 OHM +5% 62MI5W
R136	1013579091	1	PC	RMGCFMIC 1K2 OHM +5% 62MI5W
R137	1013579091	1	PC	RMGCFMIC 1K2 OHM +5% 62MI5W
R138	1013596091	1	PC	RMGCFMIC 5K6 OHM +5% 62MI5W
R139	1013596091	1	PC	RMGCFMIC 5K6 OHM +5% 62MI5W
R140	1013579091	1	PC	RMGCFMIC 1K2 OHM +5% 62MI5W
R141	1013577091	1	PC	RMGCFMIC 1K0 OHM +5% 62MI5W
R142	1013522091	1	PC	RMGCFMIC 47K0 OHM +5% 62MI5W
R143	1013577091	1	PC	RMGCFMIC 1K0 OHM +5% 62MI5W
R144	1013577091	1	PC	RMGCFMIC 1K0 OHM +5% 62MI5W
R145	1013593091	1	PC	RMGCFMIC 4K3 OHM +5% 62MI5W
R146	1013593091	1	PC	RMGCFMIC 4K3 OHM +5% 62MI5W
R147	1013593091	1	PC	RMGCFMIC 4K3 OHM +5% 62MI5W
R148	1013593091	1	PC	RMGCFMIC 4K3 OHM +5% 62MI5W
R149	1013593091	1	PC	RMGCFMIC 4K3 OHM +5% 62MI5W
R150	1013593091	1	PC	RMGCFMIC 4K3 OHM +5% 62MI5W
R151	1013593091	1	PC	RMGCFMIC 4K3 OHM +5% 62MI5W
R152	1013593091	1	PC	RMGCFMIC 4K3 OHM +5% 62MI5W
R153	1013577091	1	PC	RMGCFMIC 1K0 OHM +5% 62MI5W
R154	1013522091	1	PC	RMGCFMIC 47K0 OHM +5% 62MI5W
R155	1013522091	1	PC	RMGCFMIC 47K0 OHM +5% 62MI5W
R156	1013478091	1	PC	RMGCFMIC 150R0 OHM +5% 62MI5W
R157	1013501091	1	PC	RMGCFMIC 10K0 OHM +5% 62MI5W
R158	1013478091	1	PC	RMGCFMIC 150R0 OHM +5% 62MI5W
R159	1013501091	1	PC	RMGCFMIC 10K0 OHM +5% 62MI5W
R160	1013501091	1	PC	RMGCFMIC 10K0 OHM +5% 62MI5W
R161	1013522091	1	PC	RMGCFMIC 47K0 OHM +5% 62MI5W
R162	1013441091	1	PC	RMGCFMIC 10R0 OHM +5% 62MI5W

Ref Designator	Part Number	Qty		Description
DSP PCB				
R163	1013577091	1	PC	RMGCFMIC 1K0 OHM +5% 62MI5W
R164	1013534091	1	PC	RMGCFMIC 100K0 OHM +5% 62MI5W
R165	1013534091	1	PC	RMGCFMIC 100K0 OHM +5% 62MI5W
R166	1013534091	1	PC	RMGCFMIC 100K0 OHM +5% 62MI5W
R167	1013534091	1	PC	RMGCFMIC 100K0 OHM +5% 62MI5W
R168	1013509091	1	PC	RMGCFMIC 20K0 OHM +5% 62MI5W
R169	1013501091	1	PC	RMGCFMIC 10K0 OHM +5% 62MI5W
R170	1013501091	1	PC	RMGCFMIC 10K0 OHM +5% 62MI5W
R171	1013577091	1	PC	RMGCFMIC 1K0 OHM +5% 62MI5W
R172	1013577091	1	PC	RMGCFMIC 1K0 OHM +5% 62MI5W
R173	1013522091	1	PC	RMGCFMIC 47K0 OHM +5% 62MI5W
R174	1013522091	1	PC	RMGCFMIC 47K0 OHM +5% 62MI5W
R175	1013478091	1	PC	RMGCFMIC 150R0 OHM +5% 62MI5W
R176	1013501091	1	PC	RMGCFMIC 10K0 OHM +5% 62MI5W
R177	1013478091	1	PC	RMGCFMIC 150R0 OHM +5% 62MI5W
R178	1013501091	1	PC	RMGCFMIC 10K0 OHM +5% 62MI5W
R179	1013501091	1	PC	RMGCFMIC 10K0 OHM +5% 62MI5W
R180	1013441091	1	PC	RMGCFMIC 10R0 OHM +5% 62MI5W
R181	1013596091	1	PC	RMGCFMIC 5K6 OHM +5% 62MI5W
R182	1013596091	1	PC	RMGCFMIC 5K6 OHM +5% 62MI5W
R183	1013596091	1	PC	RMGCFMIC 5K6 OHM +5% 62MI5W
R184	1013596091	1	PC	RMGCFMIC 5K6 OHM +5% 62MI5W
R185	1013509091	1	PC	RMGCFMIC 20K0 OHM +5% 62MI5W
R186	1013501091	1	PC	RMGCFMIC 10K0 OHM +5% 62MI5W
R187	1013501091	1	PC	RMGCFMIC 10K0 OHM +5% 62MI5W
R188	1013493091	1	PC	RMGCFMIC 560R0 OHM +5% 62MI5W
R189	1013579091	1	PC	RMGCFMIC 1K2 OHM +5% 62MI5W
R190	1013579091	1	PC	RMGCFMIC 1K2 OHM +5% 62MI5W
R191	1013493091	1	PC	RMGCFMIC 560R0 OHM +5% 62MI5W
R192	1013493091	1	PC	RMGCFMIC 560R0 OHM +5% 62MI5W
R193	1013579091	1	PC	RMGCFMIC 1K2 OHM +5% 62MI5W
R194	1013579091	1	PC	RMGCFMIC 1K2 OHM +5% 62MI5W
R195	1013493091	1	PC	RMGCFMIC 560R0 OHM +5% 62MI5W
R196	1013594091	1	PC	RMGCFMIC 4K7 OHM +5% 62MI5W
R197	1013598091	1	PC	RMGCFMIC 6K8 OHM +5% 62MI5W
R198	1013579091	1	PC	RMGCFMIC 1K2 OHM +5% 62MI5W
R199	1013596091	1	PC	RMGCFMIC 5K6 OHM +5% 62MI5W
R200	1013596091	1	PC	RMGCFMIC 5K6 OHM +5% 62MI5W
R201	1013579091	1	PC	RMGCFMIC 1K2 OHM +5% 62MI5W
R202	1013579091	1	PC	RMGCFMIC 1K2 OHM +5% 62MI5W
R203	1013596091	1	PC	RMGCFMIC 5K6 OHM +5% 62MI5W
R204	1013596091	1	PC	RMGCFMIC 5K6 OHM +5% 62MI5W
R205	1013579091	1	PC	RMGCFMIC 1K2 OHM +5% 62MI5W
R206	1013577091	1	PC	RMGCFMIC 1K0 OHM +5% 62MI5W
R207	1013501091	1	PC	RMGCFMIC 10K0 OHM +5% 62MI5W
R208	1013593091	1	PC	RMGCFMIC 4K3 OHM +5% 62MI5W
R209	1013593091	1	PC	RMGCFMIC 4K3 OHM +5% 62MI5W
R210	1013593091	1	PC	RMGCFMIC 4K3 OHM +5% 62MI5W
R211	1013593091	1	PC	RMGCFMIC 4K3 OHM +5% 62MI5W
R212	1013593091	1	PC	RMGCFMIC 4K3 OHM +5% 62MI5W
R213	1013593091	1	PC	RMGCFMIC 4K3 OHM +5% 62MI5W
R214	1013593091	1	PC	RMGCFMIC 4K3 OHM +5% 62MI5W
R215	1013593091	1	PC	RMGCFMIC 4K3 OHM +5% 62MI5W
R216	1013577091	1	PC	RMGCFMIC 1K0 OHM +5% 62MI5W
R217	1013522091	1	PC	RMGCFMIC 47K0 OHM +5% 62MI5W
R218	1013478091	1	PC	RMGCFMIC 150R0 OHM +5% 62MI5W
R219	1013501091	1	PC	RMGCFMIC 10K0 OHM +5% 62MI5W
R220	1013478091	1	PC	RMGCFMIC 150R0 OHM +5% 62MI5W
R221	1013501091	1	PC	RMGCFMIC 10K0 OHM +5% 62MI5W
R222	1013522091	1	PC	RMGCFMIC 47K0 OHM +5% 62MI5W
R223	1013441091	1	PC	RMGCFMIC 10R0 OHM +5% 62MI5W
R224	1013577091	1	PC	RMGCFMIC 1K0 OHM +5% 62MI5W
R225	1013522091	1	PC	RMGCFMIC 47K0 OHM +5% 62MI5W
R226	1013509091	1	PC	RMGCFMIC 20K0 OHM +5% 62MI5W
R227	1013501091	1	PC	RMGCFMIC 10K0 OHM +5% 62MI5W
R228	1013501091	1	PC	RMGCFMIC 10K0 OHM +5% 62MI5W
R229	1013522091	1	PC	RMGCFMIC 47K0 OHM +5% 62MI5W

Ref Designator	Part Number	Qty		Description
DSP PCB				
R230	1013478091	1	PC	RMGCFMIC 150R0 OHM +5% 62MI5W
R231	1013501091	1	PC	RMGCFMIC 10K0 OHM +5% 62MI5W
R232	1013478091	1	PC	RMGCFMIC 150R0 OHM +5% 62MI5W
R233	1013577091	1	PC	RMGCFMIC 1K0 OHM +5% 62MI5W
R234	1013522091	1	PC	RMGCFMIC 47K0 OHM +5% 62MI5W
R235	1013577091	1	PC	RMGCFMIC 1K0 OHM +5% 62MI5W
R236	1013509091	1	PC	RMGCFMIC 20K0 OHM +5% 62MI5W
R237	1013501091	1	PC	RMGCFMIC 10K0 OHM +5% 62MI5W
R238	1013501091	1	PC	RMGCFMIC 10K0 OHM +5% 62MI5W
R239	1013501091	1	PC	RMGCFMIC 10K0 OHM +5% 62MI5W
R240	1013501091	1	PC	RMGCFMIC 10K0 OHM +5% 62MI5W
R241	1013441091	1	PC	RMGCFMIC 10R0 OHM +5% 62MI5W
R242	1013522091	1	PC	RMGCFMIC 47K0 OHM +5% 62MI5W
R243	1013586091	1	PC	RMGCFMIC 2K2 OHM +5% 62MI5W
R244	1013471091	1	PC	RMGCFMIC 75R0 OHM +5% 62MI5W
R245	1013522091	1	PC	RMGCFMIC 47K0 OHM +5% 62MI5W
R246	1013478091	1	PC	RMGCFMIC 150R0 OHM +5% 62MI5W
R247	1013501091	1	PC	RMGCFMIC 10K0 OHM +5% 62MI5W
R248	1013478091	1	PC	RMGCFMIC 150R0 OHM +5% 62MI5W
R249	1013501091	1	PC	RMGCFMIC 10K0 OHM +5% 62MI5W
R250	1013501091	1	PC	RMGCFMIC 10K0 OHM +5% 62MI5W
R251	1013522091	1	PC	RMGCFMIC 47K0 OHM +5% 62MI5W
R252	1013441091	1	PC	RMGCFMIC 10R0 OHM +5% 62MI5W
R253	1013441091	1	PC	RMGCFMIC 10R0 OHM +5% 62MI5W
R254	1013441091	1	PC	RMGCFMIC 10R0 OHM +5% 62MI5W
R255	1013441091	1	PC	RMGCFMIC 10R0 OHM +5% 62MI5W
R256	1013441091	1	PC	RMGCFMIC 10R0 OHM +5% 62MI5W
R257	1013441091	1	PC	RMGCFMIC 10R0 OHM +5% 62MI5W
R258	1013441091	1	PC	RMGCFMIC 10R0 OHM +5% 62MI5W
R259	1013522091	1	PC	RMGCFMIC 47K0 OHM +5% 62MI5W
R260	1013509091	1	PC	RMGCFMIC 20K0 OHM +5% 62MI5W
R261	1013501091	1	PC	RMGCFMIC 10K0 OHM +5% 62MI5W
R262	1013501091	1	PC	RMGCFMIC 10K0 OHM +5% 62MI5W
R263	1013493091	1	PC	RMGCFMIC 560R0 OHM +5% 62MI5W
R264	1013522091	1	PC	RMGCFMIC 47K0 OHM +5% 62MI5W
R265	1013586091	1	PC	RMGCFMIC 2K2 OHM +5% 62MI5W
R266	1013522091	1	PC	RMGCFMIC 47K0 OHM +5% 62MI5W
R267	1013478091	1	PC	RMGCFMIC 150R0 OHM +5% 62MI5W
R268	1013501091	1	PC	RMGCFMIC 10K0 OHM +5% 62MI5W
R269	1013478091	1	PC	RMGCFMIC 150R0 OHM +5% 62MI5W
R270	1013509091	1	PC	RMGCFMIC 20K0 OHM +5% 62MI5W
R271	1013501091	1	PC	RMGCFMIC 10K0 OHM +5% 62MI5W
R272	1013501091	1	PC	RMGCFMIC 10K0 OHM +5% 62MI5W
R273	1013501091	1	PC	RMGCFMIC 10K0 OHM +5% 62MI5W
R274	1013501091	1	PC	RMGCFMIC 10K0 OHM +5% 62MI5W
R275	1013441091	1	PC	RMGCFMIC 10R0 OHM +5% 62MI5W
R279	1013471091	1	PC	RMGCFMIC 75R0 OHM +5% 62MI5W
R280	1013577091	1	PC	RMGCFMIC 1K0 OHM +5% 62MI5W
R281	1013522091	1	PC	RMGCFMIC 47K0 OHM +5% 62MI5W
R282	1013441091	1	PC	RMGCFMIC 10R0 OHM +5% 62MI5W
R283	1013441091	1	PC	RMGCFMIC 10R0 OHM +5% 62MI5W
R284	1013441091	1	PC	RMGCFMIC 10R0 OHM +5% 62MI5W
R285	1013441091	1	PC	RMGCFMIC 10R0 OHM +5% 62MI5W
R286	1013441091	1	PC	RMGCFMIC 10R0 OHM +5% 62MI5W
R287	1013441091	1	PC	RMGCFMIC 10R0 OHM +5% 62MI5W
R288	1013522091	1	PC	RMGCFMIC 47K0 OHM +5% 62MI5W
R289	1013478091	1	PC	RMGCFMIC 150R0 OHM +5% 62MI5W
R290	1013501091	1	PC	RMGCFMIC 10K0 OHM +5% 62MI5W
R291	1013478091	1	PC	RMGCFMIC 150R0 OHM +5% 62MI5W
R292	1013501091	1	PC	RMGCFMIC 10K0 OHM +5% 62MI5W
R293	1013501091	1	PC	RMGCFMIC 10K0 OHM +5% 62MI5W
R294	1013522091	1	PC	RMGCFMIC 47K0 OHM +5% 62MI5W
R295	1013441091	1	PC	RMGCFMIC 10R0 OHM +5% 62MI5W
R296	1013493091	1	PC	RMGCFMIC 560R0 OHM +5% 62MI5W
R297	1013509091	1	PC	RMGCFMIC 20K0 OHM +5% 62MI5W
R298	1013501091	1	PC	RMGCFMIC 10K0 OHM +5% 62MI5W
R299	1013501091	1	PC	RMGCFMIC 10K0 OHM +5% 62MI5W

Ref Designator	Part Number	Qty		Description
DSP PCB				
R300	1013522091	1	PC	RMGCFMIC 47K0 OHM +5% 62MI5W
R301	1013478091	1	PC	RMGCFMIC 150R0 OHM +5% 62MI5W
R302	1013501091	1	PC	RMGCFMIC 10K0 OHM +5% 62MI5W
R303	1013478091	1	PC	RMGCFMIC 150R0 OHM +5% 62MI5W
R304	1013509091	1	PC	RMGCFMIC 20K0 OHM +5% 62MI5W
R305	1013501091	1	PC	RMGCFMIC 10K0 OHM +5% 62MI5W
R306	1013501091	1	PC	RMGCFMIC 10K0 OHM +5% 62MI5W
R307	1013501091	1	PC	RMGCFMIC 10K0 OHM +5% 62MI5W
R308	1013501091	1	PC	RMGCFMIC 10K0 OHM +5% 62MI5W
R309	1013441091	1	PC	RMGCFMIC 10R0 OHM +5% 62MI5W
R310	1013577091	1	PC	RMGCFMIC 1K0 OHM +5% 62MI5W
R312	1013586091	1	PC	RMGCFMIC 2K2 OHM +5% 62MI5W
R319	1013522091	1	PC	RMGCFMIC 47K0 OHM +5% 62MI5W
R320	1013577091	1	PC	RMGCFMIC 1K0 OHM +5% 62MI5W
R322	1013501091	1	PC	RMGCFMIC 10K0 OHM +5% 62MI5W
R323	1013501091	1	PC	RMGCFMIC 10K0 OHM +5% 62MI5W
R324	1013501091	1	PC	RMGCFMIC 10K0 OHM +5% 62MI5W
R325	1013501091	1	PC	RMGCFMIC 10K0 OHM +5% 62MI5W
R326	1013501091	1	PC	RMGCFMIC 10K0 OHM +5% 62MI5W
R327	1013501091	1	PC	RMGCFMIC 10K0 OHM +5% 62MI5W
R328	1013501091	1	PC	RMGCFMIC 10K0 OHM +5% 62MI5W
R329	1013501091	1	PC	RMGCFMIC 10K0 OHM +5% 62MI5W
R330	1013501091	1	PC	RMGCFMIC 10K0 OHM +5% 62MI5W
R331	1013494091	1	PC	RMGCFMIC 620R0 OHM +5% 62MI5W
R333	1013441091	1	PC	RMGCFMIC 10R0 OHM +5% 62MI5W
R335	1013483091	1	PC	RMGCFMIC 220R0 OHM +5% 62MI5W
R336	1013483091	1	PC	RMGCFMIC 220R0 OHM +5% 62MI5W
R337	1013474091	1	PC	RMGCFMIC 100R0 OHM +5% 62MI5W
R338	1013494091	1	PC	RMGCFMIC 620R0 OHM +5% 62MI5W
R339	1013474091	1	PC	RMGCFMIC 100R0 OHM +5% 62MI5W
R347	1013441091	1	PC	RMGCFMIC 10R0 OHM +5% 62MI5W
R348	1013441091	1	PC	RMGCFMIC 10R0 OHM +5% 62MI5W
R350	1013441091	1	PC	RMGCFMIC 10R0 OHM +5% 62MI5W
R355	1013501091	1	PC	RMGCFMIC 10K0 OHM +5% 62MI5W
R356	1013441091	1	PC	RMGCFMIC 10R0 OHM +5% 62MI5W
R357	1013474091	1	PC	RMGCFMIC 100R0 OHM +5% 62MI5W
R359	1013495091	1	PC	RMGCFMIC 680R0 OHM +5% 62MI5W
R360	1013494091	1	PC	RMGCFMIC 620R0 OHM +5% 62MI5W
R361	1013465091	1	PC	RMGCFMIC 47R0 OHM +5% 62MI5W
R362	1013441091	1	PC	RMGCFMIC 10R0 OHM +5% 62MI5W
R363	1013441091	1	PC	RMGCFMIC 10R0 OHM +5% 62MI5W
R364	1013501091	1	PC	RMGCFMIC 10K0 OHM +5% 62MI5W
R365	1013441091	1	PC	RMGCFMIC 10R0 OHM +5% 62MI5W
R366	1013594091	1	PC	RMGCFMIC 4K7 OHM +5% 62MI5W
R367	1013474091	1	PC	RMGCFMIC 100R0 OHM +5% 62MI5W
R368	1013501091	1	PC	RMGCFMIC 10K0 OHM +5% 62MI5W
R369	1013501091	1	PC	RMGCFMIC 10K0 OHM +5% 62MI5W
R370	1013501091	1	PC	RMGCFMIC 10K0 OHM +5% 62MI5W
R371	1013501091	1	PC	RMGCFMIC 10K0 OHM +5% 62MI5W
R372	1013483091	1	PC	RMGCFMIC 220R0 OHM +5% 62MI5W
R373	1013483091	1	PC	RMGCFMIC 220R0 OHM +5% 62MI5W
R374	1013501091	1	PC	RMGCFMIC 10K0 OHM +5% 62MI5W
R375	1013483091	1	PC	RMGCFMIC 220R0 OHM +5% 62MI5W
R376	1013483091	1	PC	RMGCFMIC 220R0 OHM +5% 62MI5W
R377	1013441091	1	PC	RMGCFMIC 10R0 OHM +5% 62MI5W
R378	1013441091	1	PC	RMGCFMIC 10R0 OHM +5% 62MI5W
R425	1013441091	1	PC	RMGCFMIC 10R0 OHM +5% 62MI5W
R434	1013441091	1	PC	RMGCFMIC 10R0 OHM +5% 62MI5W
R901	1013474091	1	PC	RMGCFMIC 100R0 OHM +5% 62MI5W
R902	1013474091	1	PC	RMGCFMIC 100R0 OHM +5% 62MI5W
R903	1013474091	1	PC	RMGCFMIC 100R0 OHM +5% 62MI5W
R904	1013474091	1	PC	RMGCFMIC 100R0 OHM +5% 62MI5W
R905	1013474091	1	PC	RMGCFMIC 100R0 OHM +5% 62MI5W
R908	1013594091	1	PC	RMGCFMIC 4K7 OHM +5% 62MI5W
R991	1013577091	1	PC	RMGCFMIC 1K0 OHM +5% 62MI5W
R992	1013501091	1	PC	RMGCFMIC 10K0 OHM +5% 62MI5W
R993	1013522091	1	PC	RMGCFMIC 47K0 OHM +5% 62MI5W

Ref Designator	Part Number	Qty		Description
DSP PCB				
R994	1013522091	1	PC	RMGCFMIC 47K0 OHM +5% 62MI5W
<i>Miscellaneous</i>				
NJ63	5554510NR	1	PC	CONN-SPE 87204-6063 W/ DUST CVR FE 2.77MM 9 -- 0 0
NJ71	55191450	1	PC	CON PHONO SCKT RCA 4P JW-4104RSC
NJ72	55191420	1	PC	CON PHONO SCKT RCA 4P JW-4104RSA
NJ73	55191600	1	PC	CON PHONO SCKT RCA 2P W/GND CAP JW-1502SN OO
NJ74	55125430NR	1	PC	D-LEM TORX178B RD RND CL
NJ75	55125430NR	1	PC	D-LEM TORX178B RD RND CL
NJ76	55125440NR	1	PC	D-LEM TOTX178B RD RND CL
NJ77	55246370	1	PC	CON PHONO SCKT RCA 1P W/GND JE010003LN OG
P102	55598650	1	PC	CON 2.54MM PITCH 8P HEADER LW0640-08 2.5MM PITCH
P400	55174670	1	PC	CONN 2.0MM 19 MA R NAT SOCKET MOLEX 35237-1910 0 0
P401	55174670	1	PC	CONN 2.0MM 19 MA R NAT SOCKET MOLEX 35237-1910 0 0
P402	55123320	1	PC	CONN 2.0MM 5 MA ST NAT LW2002P05 0 0
P404	55123380	1	PC	CONN 2.0MM 15 MA ST NAT LW2002P15 0 0
SK10	55179930NR	1	PC	RELAYPWR 5.0V 166.0OHM 1.0A 24.0V
T100	55176550NR	1	PC	TFPULSE TRANSFORMER 110UH FP-120 FERRIT MAGNET
T101	55176540NR	1	PC	TFPULSE TRANSFORMER 110UH FP-110 FERRIT MAGNET
Y100	55126140NR	1	PC	CRESONATOR 10M0 HZ 25.0 OHM 0F
Y101	553483500	1	PC	VCXO 12M288 HZ +50 PPM -50 PPM 0 OHM 3.3V
L113	5512669050	1	PC	FBEAD SURFACE MT 2500OHM FCM2012H-252T02
L114	5512665050	1	PC	FBEAD SURFACE MT 300OHM FCM2012V-301T07
L115	5512669050	1	PC	FBEAD SURFACE MT 2500OHM FCM2012H-252T02
L116	5512665050	1	PC	FBEAD SURFACE MT 300OHM FCM2012V-301T07
L117	5512669050	1	PC	FBEAD SURFACE MT 2500OHM FCM2012H-252T02
L120	5512669050	1	PC	FBEAD SURFACE MT 2500OHM FCM2012H-252T02
L121	5512669050	1	PC	FBEAD SURFACE MT 2500OHM FCM2012H-252T02
L100	5512669050	1	PC	FBEAD SURFACE MT 2500OHM FCM2012H-252T02
L101	5512665050	1	PC	FBEAD SURFACE MT 300OHM FCM2012V-301T07
L102	5512665050	1	PC	FBEAD SURFACE MT 300OHM FCM2012V-301T07
L103	5512669050	1	PC	FBEAD SURFACE MT 2500OHM FCM2012H-252T02
L104	5512669050	1	PC	FBEAD SURFACE MT 2500OHM FCM2012H-252T02
L105	5512665050	1	PC	FBEAD SURFACE MT 300OHM FCM2012V-301T07
L106	5512669050	1	PC	FBEAD SURFACE MT 2500OHM FCM2012H-252T02
L107	5512669050	1	PC	FBEAD SURFACE MT 2500OHM FCM2012H-252T02
L109	5512665050	1	PC	FBEAD SURFACE MT 300OHM FCM2012V-301T07
L110	5512669050	1	PC	FBEAD SURFACE MT 2500OHM FCM2012H-252T02
L111	5512669050	1	PC	FBEAD SURFACE MT 2500OHM FCM2012H-252T02
L112	5512669050	1	PC	FBEAD SURFACE MT 2500OHM FCM2012H-252T02
L118	5512665050	1	PC	FBEAD SURFACE MT 300OHM FCM2012V-301T07
L999	1013483091	1	PC	RMGCFMIC 220R0 OHM +5% 62MI5W
INPUT/PROCESSOR PCB				
<i>Capacitors</i>				
C152	1500213030	1	PC	CE 10U0F +20% 16.0V 85C
C001	2050659091	1	PC	CCCFMIC 100POF +5% -5% 50.0V NPO
C002	2050659091	1	PC	CCCFMIC 100POF +5% -5% 50.0V NPO
C003	2050659091	1	PC	CCCFMIC 100POF +5% -5% 50.0V NPO
C004	2050659091	1	PC	CCCFMIC 100POF +5% -5% 50.0V NPO
C009	2050659091	1	PC	CCCFMIC 100POF +5% -5% 50.0V NPO
C010	2050659091	1	PC	CCCFMIC 100POF +5% -5% 50.0V NPO
C011	2050659091	1	PC	CCCFMIC 100POF +5% -5% 50.0V NPO
C012	2050659091	1	PC	CCCFMIC 100POF +5% -5% 50.0V NPO
C021	2050659091	1	PC	CCCFMIC 100POF +5% -5% 50.0V NPO
C022	2050659091	1	PC	CCCFMIC 100POF +5% -5% 50.0V NPO
C023	2050659091	1	PC	CCCFMIC 100POF +5% -5% 50.0V NPO
C024	2050659091	1	PC	CCCFMIC 100POF +5% -5% 50.0V NPO
C025	2050659091	1	PC	CCCFMIC 100POF +5% -5% 50.0V NPO
C026	2050659091	1	PC	CCCFMIC 100POF +5% -5% 50.0V NPO
C027	2050659091	1	PC	CCCFMIC 100POF +5% -5% 50.0V NPO
C028	2050659091	1	PC	CCCFMIC 100POF +5% -5% 50.0V NPO
C029	2050659091	1	PC	CCCFMIC 100POF +5% -5% 50.0V NPO
C030	2050659091	1	PC	CCCFMIC 100POF +5% -5% 50.0V NPO

Ref Designator	Part Number	Qty		Description
INPUT/PROCESSOR PCB				
C031	2050659091	1	PC	CCCFMIC 100P0F +5% -5% 50.0V NP0
C032	2050659091	1	PC	CCCFMIC 100P0F +5% -5% 50.0V NP0
C033	2050659091	1	PC	CCCFMIC 100P0F +5% -5% 50.0V NP0
C034	2050659091	1	PC	CCCFMIC 100P0F +5% -5% 50.0V NP0
C035	2050659091	1	PC	CCCFMIC 100P0F +5% -5% 50.0V NP0
C036	2050659091	1	PC	CCCFMIC 100P0F +5% -5% 50.0V NP0
C043	2050659091	1	PC	CCCFMIC 100P0F +5% -5% 50.0V NP0
C044	2050659091	1	PC	CCCFMIC 100P0F +5% -5% 50.0V NP0
C045	2050659091	1	PC	CCCFMIC 100P0F +5% -5% 50.0V NP0
C046	2050659091	1	PC	CCCFMIC 100P0F +5% -5% 50.0V NP0
C047	2050659091	1	PC	CCCFMIC 100P0F +5% -5% 50.0V NP0
C048	2050659091	1	PC	CCCFMIC 100P0F +5% -5% 50.0V NP0
C049	2050659091	1	PC	CCCFMIC 100P0F +5% -5% 50.0V NP0
C050	2050659091	1	PC	CCCFMIC 100P0F +5% -5% 50.0V NP0
C051	2028804091	1	PC	CCCFMIC 100N0F +80% -20% 16.0V Y5V
C052	2028804091	1	PC	CCCFMIC 100N0F +80% -20% 16.0V Y5V
C061	2050659091	1	PC	CCCFMIC 100P0F +5% -5% 50.0V NP0
C062	2050659091	1	PC	CCCFMIC 100P0F +5% -5% 50.0V NP0
C063	2050659091	1	PC	CCCFMIC 100P0F +5% -5% 50.0V NP0
C064	2050659091	1	PC	CCCFMIC 100P0F +5% -5% 50.0V NP0
C065	2050659091	1	PC	CCCFMIC 100P0F +5% -5% 50.0V NP0
C067	2050656091	1	PC	CCCFMIC 33P0F +5% -5% 50.0V NP0
C069	2050656091	1	PC	CCCFMIC 33P0F +5% -5% 50.0V NP0
C070	2050659091	1	PC	CCCFMIC 100P0F +5% -5% 50.0V NP0
C071	2050659091	1	PC	CCCFMIC 100P0F +5% -5% 50.0V NP0
C072	2050659091	1	PC	CCCFMIC 100P0F +5% -5% 50.0V NP0
C073	2050659091	1	PC	CCCFMIC 100P0F +5% -5% 50.0V NP0
C094	1013896091	1	PC	CCCFMIC 10N0F +10% -10% 50.0V X7R
C110	2050656091	1	PC	CCCFMIC 33P0F +5% -5% 50.0V NP0
C117	2050656091	1	PC	CCCFMIC 33P0F +5% -5% 50.0V NP0
C128	1013842091	1	PC	CCCFMIC 820P0F +10% -10% 50.0V X7R
C135	1013842091	1	PC	CCCFMIC 820P0F +10% -10% 50.0V X7R
C136	2050656091	1	PC	CCCFMIC 33P0F +5% -5% 50.0V NP0
C143	2050656091	1	PC	CCCFMIC 33P0F +5% -5% 50.0V NP0
C148	1013896091	1	PC	CCCFMIC 10N0F +10% -10% 50.0V X7R
C155	2050656091	1	PC	CCCFMIC 33P0F +5% -5% 50.0V NP0
C156	2050656091	1	PC	CCCFMIC 33P0F +5% -5% 50.0V NP0
C163	2050656091	1	PC	CCCFMIC 33P0F +5% -5% 50.0V NP0
C166	2050656091	1	PC	CCCFMIC 33P0F +5% -5% 50.0V NP0
C173	2050656091	1	PC	CCCFMIC 33P0F +5% -5% 50.0V NP0
C178	2050659091	1	PC	CCCFMIC 100P0F +5% -5% 50.0V NP0
C179	2050659091	1	PC	CCCFMIC 100P0F +5% -5% 50.0V NP0
C180	2050659091	1	PC	CCCFMIC 100P0F +5% -5% 50.0V NP0
C181	2050659091	1	PC	CCCFMIC 100P0F +5% -5% 50.0V NP0
C182	2050659091	1	PC	CCCFMIC 100P0F +5% -5% 50.0V NP0
C183	2050659091	1	PC	CCCFMIC 100P0F +5% -5% 50.0V NP0
C184	2050659091	1	PC	CCCFMIC 100P0F +5% -5% 50.0V NP0
C185	2028804091	1	PC	CCCFMIC 100N0F +80% -20% 16.0V Y5V
C186	2028804091	1	PC	CCCFMIC 100N0F +80% -20% 16.0V Y5V
C187	2028804091	1	PC	CCCFMIC 100N0F +80% -20% 16.0V Y5V
C188	2050656091	1	PC	CCCFMIC 33P0F +5% -5% 50.0V NP0
C189	2050659091	1	PC	CCCFMIC 100P0F +5% -5% 50.0V NP0
C190	2028804091	1	PC	CCCFMIC 100N0F +80% -20% 16.0V Y5V
C191	2050659091	1	PC	CCCFMIC 100P0F +5% -5% 50.0V NP0
C192	2050659091	1	PC	CCCFMIC 100P0F +5% -5% 50.0V NP0
C193	2050659091	1	PC	CCCFMIC 100P0F +5% -5% 50.0V NP0
C194	2050659091	1	PC	CCCFMIC 100P0F +5% -5% 50.0V NP0
C203	2050656091	1	PC	CCCFMIC 33P0F +5% -5% 50.0V NP0
C204	2050656091	1	PC	CCCFMIC 33P0F +5% -5% 50.0V NP0
C205	2028804091	1	PC	CCCFMIC 100N0F +80% -20% 16.0V Y5V
C207	2050659091	1	PC	CCCFMIC 100P0F +5% -5% 50.0V NP0
C208	2050659091	1	PC	CCCFMIC 100P0F +5% -5% 50.0V NP0
C005	2026783030	1	PC	CE 47U0F +20% 16.0V 85C 20251640
C006	1500213030	1	PC	CE 10U0F +20% 16.0V 85C
C007	1500213030	1	PC	CE 10U0F +20% 16.0V 85C
C008	2026783030	1	PC	CE 47U0F +20% 16.0V 85C 20251640
C013	1500213030	1	PC	CE 10U0F +20% 16.0V 85C

Ref Designator	Part Number	Qty		Description
INPUT/PROCESSOR PCB				
C014	1500213030	1	PC	CE 10U0F +20% 16.0V 85C
C015	2026783030	1	PC	CE 47U0F +20% 16.0V 85C 20251640
C016	1500213030	1	PC	CE 10U0F +20% 16.0V 85C
C017	1500213030	1	PC	CE 10U0F +20% 16.0V 85C
C018	2026783030	1	PC	CE 47U0F +20% 16.0V 85C 20251640
C019	1500213030	1	PC	CE 10U0F +20% 16.0V 85C
C020	1500213030	1	PC	CE 10U0F +20% 16.0V 85C
C037	1500213030	1	PC	CE 10U0F +20% 16.0V 85C
C038	1500213030	1	PC	CE 10U0F +20% 16.0V 85C
C039	2026783030	1	PC	CE 47U0F +20% 16.0V 85C 20251640
C040	1500213030	1	PC	CE 10U0F +20% 16.0V 85C
C041	1500213030	1	PC	CE 10U0F +20% 16.0V 85C
C042	2026783030	1	PC	CE 47U0F +20% 16.0V 85C 20251640
C053	1500213030	1	PC	CE 10U0F +20% 16.0V 85C
C054	1500213030	1	PC	CE 10U0F +20% 16.0V 85C
C055	2026783030	1	PC	CE 47U0F +20% 16.0V 85C 20251640
C056	1500213030	1	PC	CE 10U0F +20% 16.0V 85C
C057	1500213030	1	PC	CE 10U0F +20% 16.0V 85C
C058	2026783030	1	PC	CE 47U0F +20% 16.0V 85C 20251640
C059	1500213030	1	PC	CE 10U0F +20% 16.0V 85C
C060	1500213030	1	PC	CE 10U0F +20% 16.0V 85C
C074	2026783030	1	PC	CE 47U0F +20% 16.0V 85C 20251640
C075	1500213030	1	PC	CE 10U0F +20% 16.0V 85C
C076	1500213030	1	PC	CE 10U0F +20% 16.0V 85C
C077	2026783030	1	PC	CE 47U0F +20% 16.0V 85C 20251640
C078	2026783030	1	PC	CE 47U0F +20% 16.0V 85C 20251640
C079	5555854030	1	PC	CE 10U0F +20% 16.0V 85C
C080	5555854030	1	PC	CE 10U0F +20% 16.0V 85C
C081	2026783030	1	PC	CE 47U0F +20% 16.0V 85C 20251640
C082	5555854030	1	PC	CE 10U0F +20% 16.0V 85C
C083	5555854030	1	PC	CE 10U0F +20% 16.0V 85C
C084	1500213030	1	PC	CE 10U0F +20% 16.0V 85C
C085	1500213030	1	PC	CE 10U0F +20% 16.0V 85C
C086	2026783030	1	PC	CE 47U0F +20% 16.0V 85C 20251640
C087	1500213030	1	PC	CE 10U0F +20% 16.0V 85C
C088	1500213030	1	PC	CE 10U0F +20% 16.0V 85C
C089	2026783030	1	PC	CE 47U0F +20% 16.0V 85C 20251640
C090	1500213030	1	PC	CE 10U0F +20% 16.0V 85C
C091	1500213030	1	PC	CE 10U0F +20% 16.0V 85C
C092	2026783030	1	PC	CE 47U0F +20% 16.0V 85C 20251640
C095	2026783030	1	PC	CE 47U0F +20% 16.0V 85C 20251640
C096	2026783030	1	PC	CE 47U0F +20% 16.0V 85C 20251640
C097	2026783030	1	PC	CE 47U0F +20% 16.0V 85C 20251640
C098	2026783030	1	PC	CE 47U0F +20% 16.0V 85C 20251640
C099	2026783030	1	PC	CE 47U0F +20% 16.0V 85C 20251640
C100	2026783030	1	PC	CE 47U0F +20% 16.0V 85C 20251640
C101	2026783030	1	PC	CE 47U0F +20% 16.0V 85C 20251640
C102	2026783030	1	PC	CE 47U0F +20% 16.0V 85C 20251640
C103	2026783030	1	PC	CE 47U0F +20% 16.0V 85C 20251640
C104	2026783030	1	PC	CE 47U0F +20% 16.0V 85C 20251640
C105	2026783030	1	PC	CE 47U0F +20% 16.0V 85C 20251640
C106	1500213030	1	PC	CE 10U0F +20% 16.0V 85C
C107	1500213030	1	PC	CE 10U0F +20% 16.0V 85C
C108	2026783030	1	PC	CE 47U0F +20% 16.0V 85C 20251640
C109	2026783030	1	PC	CE 47U0F +20% 16.0V 85C 20251640
C112	2026783030	1	PC	CE 47U0F +20% 16.0V 85C 20251640
C113	5555854030	1	PC	CE 10U0F +20% 16.0V 85C
C114	5555854030	1	PC	CE 10U0F +20% 16.0V 85C
C116	5555854030	1	PC	CE 10U0F +20% 16.0V 85C
C118	5555854030	1	PC	CE 10U0F +20% 16.0V 85C
C119	2026783030	1	PC	CE 47U0F +20% 16.0V 85C 20251640
C120	2026783030	1	PC	CE 47U0F +20% 16.0V 85C 20251640
C121	1500213030	1	PC	CE 10U0F +20% 16.0V 85C
C122	2026783030	1	PC	CE 47U0F +20% 16.0V 85C 20251640
C123	1500213030	1	PC	CE 10U0F +20% 16.0V 85C
C124	1500213030	1	PC	CE 10U0F +20% 16.0V 85C
C125	1500213030	1	PC	CE 10U0F +20% 16.0V 85C

Ref Designator	Part Number	Qty		Description
INPUT/PROCESSOR PCB				
C126	1500213030	1	PC	CE 10U0F +20% 16.0V 85C
C127	2026783030	1	PC	CE 47U0F +20% 16.0V 85C 20251640
C129	2026783030	1	PC	CE 47U0F +20% 16.0V 85C 20251640
C131	1500213030	1	PC	CE 10U0F +20% 16.0V 85C
C132	2026783030	1	PC	CE 47U0F +20% 16.0V 85C 20251640
C133	2026783030	1	PC	CE 47U0F +20% 16.0V 85C 20251640
C138	2026783030	1	PC	CE 47U0F +20% 16.0V 85C 20251640
C139	5555854030	1	PC	CE 10U0F +20% 16.0V 85C
C140	5555854030	1	PC	CE 10U0F +20% 16.0V 85C
C142	5555854030	1	PC	CE 10U0F +20% 16.0V 85C
C144	5555854030	1	PC	CE 10U0F +20% 16.0V 85C
C145	2026783030	1	PC	CE 47U0F +20% 16.0V 85C 20251640
C146	2026783030	1	PC	CE 47U0F +20% 16.0V 85C 20251640
C147	1500213030	1	PC	CE 10U0F +20% 16.0V 85C
C149	1500213030	1	PC	CE 10U0F +20% 16.0V 85C
C151	1500213030	1	PC	CE 10U0F +20% 16.0V 85C
C153	2026783030	1	PC	CE 47U0F +20% 16.0V 85C 20251640
C158	2026783030	1	PC	CE 47U0F +20% 16.0V 85C 20251640
C159	1500213030	1	PC	CE 10U0F +20% 16.0V 85C
C160	1500213030	1	PC	CE 10U0F +20% 16.0V 85C
C162	1500213030	1	PC	CE 10U0F +20% 16.0V 85C
C164	1500213030	1	PC	CE 10U0F +20% 16.0V 85C
C165	2026783030	1	PC	CE 47U0F +20% 16.0V 85C 20251640
C168	2026783030	1	PC	CE 47U0F +20% 16.0V 85C 20251640
C169	1500213030	1	PC	CE 10U0F +20% 16.0V 85C
C170	1500213030	1	PC	CE 10U0F +20% 16.0V 85C
C172	1500213030	1	PC	CE 10U0F +20% 16.0V 85C
C174	1500213030	1	PC	CE 10U0F +20% 16.0V 85C
C175	2026783030	1	PC	CE 47U0F +20% 16.0V 85C 20251640
C176	4043309030	1	PC	CE 1M10F +20% 6.3V 85C
C177	4043309030	1	PC	CE 1M10F +20% 6.3V 85C
C195	1500213030	1	PC	CE 10U0F +20% 16.0V 85C
C196	1500213030	1	PC	CE 10U0F +20% 16.0V 85C
C197	1500213030	1	PC	CE 10U0F +20% 16.0V 85C
C198	1500213030	1	PC	CE 10U0F +20% 16.0V 85C
C201	2026783030	1	PC	CE 47U0F +20% 16.0V 85C 20251640
C202	2026783030	1	PC	CE 47U0F +20% 16.0V 85C 20251640
C206	2026783030	1	PC	CE 47U0F +20% 16.0V 85C 20251640
C066	2050656091	1	PC	CCCFMIC 33P0F +5% -5% 50.0V NP0
C068	2050656091	1	PC	CCCFMIC 33P0F +5% -5% 50.0V NP0
C093	2028804091	1	PC	CCCFMIC 100N0F +80% -20% 16.0V Y5V
C111	2050656091	1	PC	CCCFMIC 33P0F +5% -5% 50.0V NP0
C115	2050656091	1	PC	CCCFMIC 33P0F +5% -5% 50.0V NP0
C130	2050656091	1	PC	CCCFMIC 33P0F +5% -5% 50.0V NP0
C134	2050656091	1	PC	CCCFMIC 33P0F +5% -5% 50.0V NP0
C137	2050656091	1	PC	CCCFMIC 33P0F +5% -5% 50.0V NP0
C141	2050656091	1	PC	CCCFMIC 33P0F +5% -5% 50.0V NP0
C150	1013862091	1	PC	CCCFMIC 2N2F +10% -10% 50.0V X7R
C154	2050656091	1	PC	CCCFMIC 33P0F +5% -5% 50.0V NP0
C157	2050656091	1	PC	CCCFMIC 33P0F +5% -5% 50.0V NP0
C161	2050656091	1	PC	CCCFMIC 33P0F +5% -5% 50.0V NP0
C167	2050656091	1	PC	CCCFMIC 33P0F +5% -5% 50.0V NP0
C171	2050656091	1	PC	CCCFMIC 33P0F +5% -5% 50.0V NP0
C199	2050656091	1	PC	CCCFMIC 33P0F +5% -5% 50.0V NP0
C200	2050656091	1	PC	CCCFMIC 33P0F +5% -5% 50.0V NP0
Semiconductors				
D027	2042121016	1	PC	D-ZENER 1N5242B 12.0V 500MI0W
IC06	55142750MU	1	PC	IC-SWITCH TC9273N-007 DIP28 ANALOG SWITCH
IC10	55142750MU	1	PC	IC-SWITCH TC9273N-007 DIP28 ANALOG SWITCH
Q002	5514267056	1	PC	TR-SLPLF MPSA06 N 500MIOA
Q005	5513335056	1	PC	TR-SLPLF MPSA56 Y P -500MIOA -300V
Q006	5513329056	1	PC	TR-SLPLF KTD1302 B N 300MIOA 20V
Q018	5513329056	1	PC	TR-SLPLF KTD1302 B N 300MIOA 20V
Q022	5513329056	1	PC	TR-SLPLF KTD1302 B N 300MIOA 20V
Q047	5513329056	1	PC	TR-SLPLF KTD1302 B N 300MIOA 20V

Ref Designator	Part Number	Qty		Description
INPUT/PROCESSOR PCB				
Q048	5513335056	1	PC	TR-SLPLF MPSA56 Y P -500MIOA -300V
Q049	5514267056	1	PC	TR-SLPLF MPSA06 N 500MIOA
D002	2049651085	1	PC	D-SLP 1SS355 35.0V 225MIOA
D018	5550638050	1	PC	D-ZENER UDZS 9.1B 9.1V 200MIOW
D019	5517771050	1	PC	D-ZENER UDZS 5.1 B 5.1V 200MIOW
Q001	5513871092	1	PC	TR-SLPSWA KTD1304 N 20V 300MIOA
Q004	5513318092	1	PC	TR-SSD DTC114YKA N 10K0 OHM 47K0 OHM
Q019	5513871092	1	PC	TR-SLPSWA KTD1304 N 20V 300MIOA
Q021	5513319092	1	PC	TR-SSD DTA114YKA P 10K0 OHM 47K0 OHM
Q024	5513871092	1	PC	TR-SLPSWA KTD1304 N 20V 300MIOA
Q026	5513871092	1	PC	TR-SLPSWA KTD1304 N 20V 300MIOA
Q027	5513871092	1	PC	TR-SLPSWA KTD1304 N 20V 300MIOA
Q028	5513871092	1	PC	TR-SLPSWA KTD1304 N 20V 300MIOA
Q029	5513871092	1	PC	TR-SLPSWA KTD1304 N 20V 300MIOA
Q030	5513871092	1	PC	TR-SLPSWA KTD1304 N 20V 300MIOA
Q031	5513871092	1	PC	TR-SLPSWA KTD1304 N 20V 300MIOA
Q033	5513871092	1	PC	TR-SLPSWA KTD1304 N 20V 300MIOA
Q036	5513871092	1	PC	TR-SLPSWA KTD1304 N 20V 300MIOA
Q038	5513871092	1	PC	TR-SLPSWA KTD1304 N 20V 300MIOA
Q039	5513871092	1	PC	TR-SLPSWA KTD1304 N 20V 300MIOA
Q040	5513871092	1	PC	TR-SLPSWA KTD1304 N 20V 300MIOA
Q042	5513871092	1	PC	TR-SLPSWA KTD1304 N 20V 300MIOA
Q044	5513871092	1	PC	TR-SLPSWA KTD1304 N 20V 300MIOA
Q045	5513871092	1	PC	TR-SLPSWA KTD1304 N 20V 300MIOA
Q046	5513871092	1	PC	TR-SLPSWA KTD1304 N 20V 300MIOA
Q054	5513318092	1	PC	TR-SSD DTC114YKA N 10K0 OHM 47K0 OHM
D001	5550638050	1	PC	D-ZENER UDZS 9.1B 9.1V 200MIOW
D006	2049651085	1	PC	D-SLP 1SS355 35.0V 225MIOA
D008	5550638050	1	PC	D-ZENER UDZS 9.1B 9.1V 200MIOW
D009	5550638050	1	PC	D-ZENER UDZS 9.1B 9.1V 200MIOW
D012	5550638050	1	PC	D-ZENER UDZS 9.1B 9.1V 200MIOW
D014	5550638050	1	PC	D-ZENER UDZS 9.1B 9.1V 200MIOW
D015	2049651085	1	PC	D-SLP 1SS355 35.0V 225MIOA
D016	2049651085	1	PC	D-SLP 1SS355 35.0V 225MIOA
D017	2049651085	1	PC	D-SLP 1SS355 35.0V 225MIOA
D021	5550638050	1	PC	D-ZENER UDZS 9.1B 9.1V 200MIOW
IC01	55142610MT	1	PC	IC-OPERAMP NJM2068M DUAL OP
IC02	55142720MU	1	PC	IC-LOWFREQ KIC9459F SOP24 TONE/VOL/BAL/MUTE
IC03	55506490MT	1	PC	IC-SWITCH NJU7312AM ANALOG SWITCH
IC04	55142610MT	1	PC	IC-OPERAMP NJM2068M DUAL OP
IC05	55506480MT	1	PC	IC-SWITCH NJU7311AM ANALOG SWITCH
IC07	55142610MT	1	PC	IC-OPERAMP NJM2068M DUAL OP
IC08	55142610MT	1	PC	IC-OPERAMP NJM2068M DUAL OP
IC09	55142610MT	1	PC	IC-OPERAMP NJM2068M DUAL OP
IC11	55142610MT	1	PC	IC-OPERAMP NJM2068M DUAL OP
IC12	55142610MT	1	PC	IC-OPERAMP NJM2068M DUAL OP
IC13	55142610MT	1	PC	IC-OPERAMP NJM2068M DUAL OP
IC14	55506480MT	1	PC	IC-SWITCH NJU7311AM ANALOG SWITCH
IC15	55142610MT	1	PC	IC-OPERAMP NJM2068M DUAL OP
IC16	55142610MT	1	PC	IC-OPERAMP NJM2068M DUAL OP
IC17	55142610MT	1	PC	IC-OPERAMP NJM2068M DUAL OP
IC18	55142720MU	1	PC	IC-LOWFREQ KIC9459F SOP24 TONE/VOL/BAL/MUTE
IC19	55179480KV	1	PC	IC-LOWFREQ TC9482F SOP28 TONE/VOL/BAL/MUTE
IC20	55142590MT	1	PC	IC-OPERAMP NJM5532M DUAL OP
IC21	55142610MT	1	PC	IC-OPERAMP NJM2068M DUAL OP
IC22	55142610MT	1	PC	IC-OPERAMP NJM2068M DUAL OP
IC23	55142610MT	1	PC	IC-OPERAMP NJM2068M DUAL OP
IC24	55142610MT	1	PC	IC-OPERAMP NJM2068M DUAL OP
IC25	55142610MT	1	PC	IC-OPERAMP NJM2068M DUAL OP
IC26	55142610MT	1	PC	IC-OPERAMP NJM2068M DUAL OP
Q003	5513319092	1	PC	TR-SSD DTA114YKA P 10K0 OHM 47K0 OHM
Q007	5513871092	1	PC	TR-SLPSWA KTD1304 N 20V 300MIOA
Q008	5513871092	1	PC	TR-SLPSWA KTD1304 N 20V 300MIOA
Q009	5513871092	1	PC	TR-SLPSWA KTD1304 N 20V 300MIOA
Q010	5513871092	1	PC	TR-SLPSWA KTD1304 N 20V 300MIOA
Q011	5513871092	1	PC	TR-SLPSWA KTD1304 N 20V 300MIOA
Q012	5513871092	1	PC	TR-SLPSWA KTD1304 N 20V 300MIOA

Ref Designator	Part Number	Qty		Description
INPUT/PROCESSOR PCB				
Q013	5513319092	1	PC	TR-SSD DTA114YKA P 10K0 OHM 47K0 OHM
Q014	5513319092	1	PC	TR-SSD DTA114YKA P 10K0 OHM 47K0 OHM
Q015	5513871092	1	PC	TR-SLPSWA KTD1304 N 20V 300MIOA
Q016	5513871092	1	PC	TR-SLPSWA KTD1304 N 20V 300MIOA
Q017	5513319092	1	PC	TR-SSD DTA114YKA P 10K0 OHM 47K0 OHM
Q020	5513319092	1	PC	TR-SSD DTA114YKA P 10K0 OHM 47K0 OHM
Q023	5513319092	1	PC	TR-SSD DTA114YKA P 10K0 OHM 47K0 OHM
Q025	5513319092	1	PC	TR-SSD DTA114YKA P 10K0 OHM 47K0 OHM
Q032	5513319092	1	PC	TR-SSD DTA114YKA P 10K0 OHM 47K0 OHM
Q034	5513319092	1	PC	TR-SSD DTA114YKA P 10K0 OHM 47K0 OHM
Q035	5513319092	1	PC	TR-SSD DTA114YKA P 10K0 OHM 47K0 OHM
Q037	5513319092	1	PC	TR-SSD DTA114YKA P 10K0 OHM 47K0 OHM
Q041	5513319092	1	PC	TR-SSD DTA114YKA P 10K0 OHM 47K0 OHM
Q043	5513319092	1	PC	TR-SSD DTA114YKA P 10K0 OHM 47K0 OHM
Q050	5513319092	1	PC	TR-SSD DTA114YKA P 10K0 OHM 47K0 OHM
Q051	5513871092	1	PC	TR-SLPSWA KTD1304 N 20V 300MIOA
Q052	5513319092	1	PC	TR-SSD DTA114YKA P 10K0 OHM 47K0 OHM
Q053	5513871092	1	PC	TR-SLPSWA KTD1304 N 20V 300MIOA
Q058	5513871092	1	PC	TR-SLPSWA KTD1304 N 20V 300MIOA
Q059	5513871092	1	PC	TR-SLPSWA KTD1304 N 20V 300MIOA
<i>Resistors</i>				
J007	1032875091	1	PC	RMGCFMIC 0 OHM +0% 62MI5W
J008	1032875091	1	PC	RMGCFMIC 0 OHM +0% 62MI5W
J009	1032875091	1	PC	RMGCFMIC 0 OHM +0% 62MI5W
J010	1032875091	1	PC	RMGCFMIC 0 OHM +0% 62MI5W
J011	1032875091	1	PC	RMGCFMIC 0 OHM +0% 62MI5W
J012	1032875091	1	PC	RMGCFMIC 0 OHM +0% 62MI5W
J026	1032875091	1	PC	RMGCFMIC 0 OHM +0% 62MI5W
J031	1032875091	1	PC	RMGCFMIC 0 OHM +0% 62MI5W
J034	1032875091	1	PC	RMGCFMIC 0 OHM +0% 62MI5W
J038	1032875091	1	PC	RMGCFMIC 0 OHM +0% 62MI5W
J039	1032875091	1	PC	RMGCFMIC 0 OHM +0% 62MI5W
J040	1032875091	1	PC	RMGCFMIC 0 OHM +0% 62MI5W
J041	1032875091	1	PC	RMGCFMIC 0 OHM +0% 62MI5W
R001	1013474091	1	PC	RMGCFMIC 100R0 OHM +5% 62MI5W
R002	1013534091	1	PC	RMGCFMIC 100K0 OHM +5% 62MI5W
R003	1013491091	1	PC	RMGCFMIC 470R0 OHM +5% 62MI5W
R004	1013491091	1	PC	RMGCFMIC 470R0 OHM +5% 62MI5W
R005	1013534091	1	PC	RMGCFMIC 100K0 OHM +5% 62MI5W
R006	1013491091	1	PC	RMGCFMIC 470R0 OHM +5% 62MI5W
R009	1013491091	1	PC	RMGCFMIC 470R0 OHM +5% 62MI5W
R010	1013474091	1	PC	RMGCFMIC 100R0 OHM +5% 62MI5W
R011	1013474091	1	PC	RMGCFMIC 100R0 OHM +5% 62MI5W
R012	1013534091	1	PC	RMGCFMIC 100K0 OHM +5% 62MI5W
R013	1013474091	1	PC	RMGCFMIC 100R0 OHM +5% 62MI5W
R014	1013534091	1	PC	RMGCFMIC 100K0 OHM +5% 62MI5W
R015	1013534091	1	PC	RMGCFMIC 100K0 OHM +5% 62MI5W
R016	1013534091	1	PC	RMGCFMIC 100K0 OHM +5% 62MI5W
R017	1013534091	1	PC	RMGCFMIC 100K0 OHM +5% 62MI5W
R018	1013474091	1	PC	RMGCFMIC 100R0 OHM +5% 62MI5W
R020	1013517091	1	PC	RMGCFMIC 33K0 OHM +5% 62MI5W
R021	1013534091	1	PC	RMGCFMIC 100K0 OHM +5% 62MI5W
R022	1013491091	1	PC	RMGCFMIC 470R0 OHM +5% 62MI5W
R025	1013491091	1	PC	RMGCFMIC 470R0 OHM +5% 62MI5W
R026	1013534091	1	PC	RMGCFMIC 100K0 OHM +5% 62MI5W
R027	1013491091	1	PC	RMGCFMIC 470R0 OHM +5% 62MI5W
R028	1013534091	1	PC	RMGCFMIC 100K0 OHM +5% 62MI5W
R029	1013491091	1	PC	RMGCFMIC 470R0 OHM +5% 62MI5W
R030	1013474091	1	PC	RMGCFMIC 100R0 OHM +5% 62MI5W
R031	1013474091	1	PC	RMGCFMIC 100R0 OHM +5% 62MI5W
R032	1013491091	1	PC	RMGCFMIC 470R0 OHM +5% 62MI5W
R033	1013534091	1	PC	RMGCFMIC 100K0 OHM +5% 62MI5W
R034	1013491091	1	PC	RMGCFMIC 470R0 OHM +5% 62MI5W
R035	1013534091	1	PC	RMGCFMIC 100K0 OHM +5% 62MI5W
R036	1013491091	1	PC	RMGCFMIC 470R0 OHM +5% 62MI5W

Ref Designator	Part Number	Qty		Description
INPUT/PROCESSOR PCB				
R039	1013491091	1	PC	RMGCFMIC 470R0 OHM +5% 62MI5W
R040	1013534091	1	PC	RMGCFMIC 100K0 OHM +5% 62MI5W
R041	1013534091	1	PC	RMGCFMIC 100K0 OHM +5% 62MI5W
R042	1013534091	1	PC	RMGCFMIC 100K0 OHM +5% 62MI5W
R043	1013534091	1	PC	RMGCFMIC 100K0 OHM +5% 62MI5W
R044	1013474091	1	PC	RMGCFMIC 100R0 OHM +5% 62MI5W
R045	1013534091	1	PC	RMGCFMIC 100K0 OHM +5% 62MI5W
R046	1013491091	1	PC	RMGCFMIC 470R0 OHM +5% 62MI5W
R047	1013534091	1	PC	RMGCFMIC 100K0 OHM +5% 62MI5W
R048	1013491091	1	PC	RMGCFMIC 470R0 OHM +5% 62MI5W
R049	1013491091	1	PC	RMGCFMIC 470R0 OHM +5% 62MI5W
R050	1013534091	1	PC	RMGCFMIC 100K0 OHM +5% 62MI5W
R051	1013491091	1	PC	RMGCFMIC 470R0 OHM +5% 62MI5W
R052	1013534091	1	PC	RMGCFMIC 100K0 OHM +5% 62MI5W
R056	1013517091	1	PC	RMGCFMIC 33K0 OHM +5% 62MI5W
R057	1013491091	1	PC	RMGCFMIC 470R0 OHM +5% 62MI5W
R058	1013534091	1	PC	RMGCFMIC 100K0 OHM +5% 62MI5W
R059	1013491091	1	PC	RMGCFMIC 470R0 OHM +5% 62MI5W
R060	1013534091	1	PC	RMGCFMIC 100K0 OHM +5% 62MI5W
R061	1013577091	1	PC	RMGCFMIC 1K0 OHM +5% 62MI5W
R062	1013517091	1	PC	RMGCFMIC 33K0 OHM +5% 62MI5W
R063	1013474091	1	PC	RMGCFMIC 100R0 OHM +5% 62MI5W
R064	1013474091	1	PC	RMGCFMIC 100R0 OHM +5% 62MI5W
R065	1013534091	1	PC	RMGCFMIC 100K0 OHM +5% 62MI5W
R066	1013534091	1	PC	RMGCFMIC 100K0 OHM +5% 62MI5W
R067	1013534091	1	PC	RMGCFMIC 100K0 OHM +5% 62MI5W
R068	1013534091	1	PC	RMGCFMIC 100K0 OHM +5% 62MI5W
R069	1013595091	1	PC	RMGCFMIC 5K1 OHM +5% 62MI5W
R070	1013595091	1	PC	RMGCFMIC 5K1 OHM +5% 62MI5W
R071	1013577091	1	PC	RMGCFMIC 1K0 OHM +5% 62MI5W
R073	1013491091	1	PC	RMGCFMIC 470R0 OHM +5% 62MI5W
R074	1013517091	1	PC	RMGCFMIC 33K0 OHM +5% 62MI5W
R075	1013474091	1	PC	RMGCFMIC 100R0 OHM +5% 62MI5W
R076	1013491091	1	PC	RMGCFMIC 470R0 OHM +5% 62MI5W
R077	1013474091	1	PC	RMGCFMIC 100R0 OHM +5% 62MI5W
R078	1013474091	1	PC	RMGCFMIC 100R0 OHM +5% 62MI5W
R079	1013474091	1	PC	RMGCFMIC 100R0 OHM +5% 62MI5W
R085	1013534091	1	PC	RMGCFMIC 100K0 OHM +5% 62MI5W
R086	1013534091	1	PC	RMGCFMIC 100K0 OHM +5% 62MI5W
R091	1013577091	1	PC	RMGCFMIC 1K0 OHM +5% 62MI5W
R092	1013577091	1	PC	RMGCFMIC 1K0 OHM +5% 62MI5W
R093	1013577091	1	PC	RMGCFMIC 1K0 OHM +5% 62MI5W
R094	1013577091	1	PC	RMGCFMIC 1K0 OHM +5% 62MI5W
R095	1013577091	1	PC	RMGCFMIC 1K0 OHM +5% 62MI5W
R096	1013577091	1	PC	RMGCFMIC 1K0 OHM +5% 62MI5W
R099	1013534091	1	PC	RMGCFMIC 100K0 OHM +5% 62MI5W
R100	1013534091	1	PC	RMGCFMIC 100K0 OHM +5% 62MI5W
R101	1013474091	1	PC	RMGCFMIC 100R0 OHM +5% 62MI5W
R103	1013534091	1	PC	RMGCFMIC 100K0 OHM +5% 62MI5W
R104	1013534091	1	PC	RMGCFMIC 100K0 OHM +5% 62MI5W
R106	1013474091	1	PC	RMGCFMIC 100R0 OHM +5% 62MI5W
R107	1013474091	1	PC	RMGCFMIC 100R0 OHM +5% 62MI5W
R109	1013534091	1	PC	RMGCFMIC 100K0 OHM +5% 62MI5W
R110	1013534091	1	PC	RMGCFMIC 100K0 OHM +5% 62MI5W
R112	1013474091	1	PC	RMGCFMIC 100R0 OHM +5% 62MI5W
R113	1013534091	1	PC	RMGCFMIC 100K0 OHM +5% 62MI5W
R114	1013534091	1	PC	RMGCFMIC 100K0 OHM +5% 62MI5W
R115	1013517091	1	PC	RMGCFMIC 33K0 OHM +5% 62MI5W
R116	1013517091	1	PC	RMGCFMIC 33K0 OHM +5% 62MI5W
R117	1013517091	1	PC	RMGCFMIC 33K0 OHM +5% 62MI5W
R118	1013517091	1	PC	RMGCFMIC 33K0 OHM +5% 62MI5W
R119	1013534091	1	PC	RMGCFMIC 100K0 OHM +5% 62MI5W
R120	1013534091	1	PC	RMGCFMIC 100K0 OHM +5% 62MI5W
R121	1013474091	1	PC	RMGCFMIC 100R0 OHM +5% 62MI5W
R123	1013534091	1	PC	RMGCFMIC 100K0 OHM +5% 62MI5W
R124	1013534091	1	PC	RMGCFMIC 100K0 OHM +5% 62MI5W
R126	1013474091	1	PC	RMGCFMIC 100R0 OHM +5% 62MI5W

Ref Designator	Part Number	Qty		Description
INPUT/PROCESSOR PCB				
R127	1013491091	1	PC	RMGCFMIC 470R0 OHM +5% 62MI5W
R128	1013594091	1	PC	RMGCFMIC 4K7 OHM +5% 62MI5W
R129	1013534091	1	PC	RMGCFMIC 100K0 OHM +5% 62MI5W
R130	1013534091	1	PC	RMGCFMIC 100K0 OHM +5% 62MI5W
R131	1013474091	1	PC	RMGCFMIC 100R0 OHM +5% 62MI5W
R132	1013585091	1	PC	RMGCFMIC 2K0 OHM +5% 62MI5W
R133	1013474091	1	PC	RMGCFMIC 100R0 OHM +5% 62MI5W
R134	1013503091	1	PC	RMGCFMIC 12K0 OHM +5% 62MI5W
R136	1013474091	1	PC	RMGCFMIC 100R0 OHM +5% 62MI5W
R137	1013474091	1	PC	RMGCFMIC 100R0 OHM +5% 62MI5W
R138	1013577091	1	PC	RMGCFMIC 1K0 OHM +5% 62MI5W
R139	1013577091	1	PC	RMGCFMIC 1K0 OHM +5% 62MI5W
R140	1013577091	1	PC	RMGCFMIC 1K0 OHM +5% 62MI5W
R141	1013474091	1	PC	RMGCFMIC 100R0 OHM +5% 62MI5W
R142	1013474091	1	PC	RMGCFMIC 100R0 OHM +5% 62MI5W
R143	1013577091	1	PC	RMGCFMIC 1K0 OHM +5% 62MI5W
R144	1013577091	1	PC	RMGCFMIC 1K0 OHM +5% 62MI5W
R145	1013577091	1	PC	RMGCFMIC 1K0 OHM +5% 62MI5W
R146	1013534091	1	PC	RMGCFMIC 100K0 OHM +5% 62MI5W
R147	1013534091	1	PC	RMGCFMIC 100K0 OHM +5% 62MI5W
R148	1013491091	1	PC	RMGCFMIC 470R0 OHM +5% 62MI5W
R149	1013491091	1	PC	RMGCFMIC 470R0 OHM +5% 62MI5W
R150	1013577091	1	PC	RMGCFMIC 1K0 OHM +5% 62MI5W
R151	1013577091	1	PC	RMGCFMIC 1K0 OHM +5% 62MI5W
R152	1013577091	1	PC	RMGCFMIC 1K0 OHM +5% 62MI5W
R153	1013577091	1	PC	RMGCFMIC 1K0 OHM +5% 62MI5W
R154	1013577091	1	PC	RMGCFMIC 1K0 OHM +5% 62MI5W
R155	1013577091	1	PC	RMGCFMIC 1K0 OHM +5% 62MI5W
R161	1013534091	1	PC	RMGCFMIC 100K0 OHM +5% 62MI5W
R162	1013534091	1	PC	RMGCFMIC 100K0 OHM +5% 62MI5W
R163	1013503091	1	PC	RMGCFMIC 12K0 OHM +5% 62MI5W
R164	1013503091	1	PC	RMGCFMIC 12K0 OHM +5% 62MI5W
R165	1013503091	1	PC	RMGCFMIC 12K0 OHM +5% 62MI5W
R166	1013474091	1	PC	RMGCFMIC 100R0 OHM +5% 62MI5W
R167	1013474091	1	PC	RMGCFMIC 100R0 OHM +5% 62MI5W
R168	1013577091	1	PC	RMGCFMIC 1K0 OHM +5% 62MI5W
R169	1013577091	1	PC	RMGCFMIC 1K0 OHM +5% 62MI5W
R170	1013577091	1	PC	RMGCFMIC 1K0 OHM +5% 62MI5W
R171	1013474091	1	PC	RMGCFMIC 100R0 OHM +5% 62MI5W
R172	1013474091	1	PC	RMGCFMIC 100R0 OHM +5% 62MI5W
R173	1013498091	1	PC	RMGCFMIC 820R0 OHM +5% 62MI5W
R174	1013474091	1	PC	RMGCFMIC 100R0 OHM +5% 62MI5W
R175	1013534091	1	PC	RMGCFMIC 100K0 OHM +5% 62MI5W
R176	1013534091	1	PC	RMGCFMIC 100K0 OHM +5% 62MI5W
R177	1013593091	1	PC	RMGCFMIC 4K3 OHM +5% 62MI5W
R178	1013491091	1	PC	RMGCFMIC 470R0 OHM +5% 62MI5W
R179	1013593091	1	PC	RMGCFMIC 4K3 OHM +5% 62MI5W
R180	1013498091	1	PC	RMGCFMIC 820R0 OHM +5% 62MI5W
R181	1013534091	1	PC	RMGCFMIC 100K0 OHM +5% 62MI5W
R182	1013491091	1	PC	RMGCFMIC 470R0 OHM +5% 62MI5W
R183	1013534091	1	PC	RMGCFMIC 100K0 OHM +5% 62MI5W
R184	1013474091	1	PC	RMGCFMIC 100R0 OHM +5% 62MI5W
R185	1013474091	1	PC	RMGCFMIC 100R0 OHM +5% 62MI5W
R186	1013534091	1	PC	RMGCFMIC 100K0 OHM +5% 62MI5W
R187	1013491091	1	PC	RMGCFMIC 470R0 OHM +5% 62MI5W
R188	1013534091	1	PC	RMGCFMIC 100K0 OHM +5% 62MI5W
R189	1013474091	1	PC	RMGCFMIC 100R0 OHM +5% 62MI5W
R190	1013517091	1	PC	RMGCFMIC 33K0 OHM +5% 62MI5W
R191	1013534091	1	PC	RMGCFMIC 100K0 OHM +5% 62MI5W
R192	1013534091	1	PC	RMGCFMIC 100K0 OHM +5% 62MI5W
R193	1013534091	1	PC	RMGCFMIC 100K0 OHM +5% 62MI5W
R194	1013534091	1	PC	RMGCFMIC 100K0 OHM +5% 62MI5W
R195	1013474091	1	PC	RMGCFMIC 100R0 OHM +5% 62MI5W
R196	1013503091	1	PC	RMGCFMIC 12K0 OHM +5% 62MI5W
R198	1013474091	1	PC	RMGCFMIC 100R0 OHM +5% 62MI5W
R199	1013596091	1	PC	RMGCFMIC 5K6 OHM +5% 62MI5W
R200	1013582091	1	PC	RMGCFMIC 1K5 OHM +5% 62MI5W

Ref Designator	Part Number	Qty		Description
INPUT/PROCESSOR PCB				
R202	1013582091	1	PC	RMGCFMIC 1K5 OHM +5% 62MI5W
R203	1013503091	1	PC	RMGCFMIC 12K0 OHM +5% 62MI5W
R204	1013474091	1	PC	RMGCFMIC 100R0 OHM +5% 62MI5W
R205	1013577091	1	PC	RMGCFMIC 1K0 OHM +5% 62MI5W
R206	1013596091	1	PC	RMGCFMIC 5K6 OHM +5% 62MI5W
R207	1013589091	1	PC	RMGCFMIC 3K0 OHM +5% 62MI5W
R212	1013594091	1	PC	RMGCFMIC 4K7 OHM +5% 62MI5W
R215	1013589091	1	PC	RMGCFMIC 3K0 OHM +5% 62MI5W
R216	1013594091	1	PC	RMGCFMIC 4K7 OHM +5% 62MI5W
R220	1013586091	1	PC	RMGCFMIC 2K2 OHM +5% 62MI5W
R221	1013577091	1	PC	RMGCFMIC 1K0 OHM +5% 62MI5W
R222	1013591091	1	PC	RMGCFMIC 3K6 OHM +5% 62MI5W
R226	1013586091	1	PC	RMGCFMIC 2K2 OHM +5% 62MI5W
R229	1013577091	1	PC	RMGCFMIC 1K0 OHM +5% 62MI5W
R230	1013591091	1	PC	RMGCFMIC 3K6 OHM +5% 62MI5W
R231	1013594091	1	PC	RMGCFMIC 4K7 OHM +5% 62MI5W
R233	1013534091	1	PC	RMGCFMIC 100K0 OHM +5% 62MI5W
R234	1013534091	1	PC	RMGCFMIC 100K0 OHM +5% 62MI5W
R235	1013582091	1	PC	RMGCFMIC 1K5 OHM +5% 62MI5W
R236	1013517091	1	PC	RMGCFMIC 33K0 OHM +5% 62MI5W
R237	1013582091	1	PC	RMGCFMIC 1K5 OHM +5% 62MI5W
R238	1013594091	1	PC	RMGCFMIC 4K7 OHM +5% 62MI5W
R239	1013534091	1	PC	RMGCFMIC 100K0 OHM +5% 62MI5W
R240	1013595091	1	PC	RMGCFMIC 5K1 OHM +5% 62MI5W
R241	1013534091	1	PC	RMGCFMIC 100K0 OHM +5% 62MI5W
R244	1013534091	1	PC	RMGCFMIC 100K0 OHM +5% 62MI5W
R245	1013534091	1	PC	RMGCFMIC 100K0 OHM +5% 62MI5W
R246	1013534091	1	PC	RMGCFMIC 100K0 OHM +5% 62MI5W
R247	1013577091	1	PC	RMGCFMIC 1K0 OHM +5% 62MI5W
R248	1013601091	1	PC	RMGCFMIC 9K1 OHM +5% 62MI5W
R249	1013577091	1	PC	RMGCFMIC 1K0 OHM +5% 62MI5W
R250	1013595091	1	PC	RMGCFMIC 5K1 OHM +5% 62MI5W
R251	1013534091	1	PC	RMGCFMIC 100K0 OHM +5% 62MI5W
R252	1013534091	1	PC	RMGCFMIC 100K0 OHM +5% 62MI5W
R254	1013577091	1	PC	RMGCFMIC 1K0 OHM +5% 62MI5W
R255	1013585091	1	PC	RMGCFMIC 2K0 OHM +5% 62MI5W
R256	1013577091	1	PC	RMGCFMIC 1K0 OHM +5% 62MI5W
R259	1013586091	1	PC	RMGCFMIC 2K2 OHM +5% 62MI5W
R263	1013584091	1	PC	RMGCFMIC 1K8 OHM +5% 62MI5W
R264	1013577091	1	PC	RMGCFMIC 1K0 OHM +5% 62MI5W
R268	1013586091	1	PC	RMGCFMIC 2K2 OHM +5% 62MI5W
R269	1013577091	1	PC	RMGCFMIC 1K0 OHM +5% 62MI5W
R270	1013585091	1	PC	RMGCFMIC 2K0 OHM +5% 62MI5W
R274	1013586091	1	PC	RMGCFMIC 2K2 OHM +5% 62MI5W
R277	1013577091	1	PC	RMGCFMIC 1K0 OHM +5% 62MI5W
R278	1013585091	1	PC	RMGCFMIC 2K0 OHM +5% 62MI5W
R279	1013577091	1	PC	RMGCFMIC 1K0 OHM +5% 62MI5W
R281	1013534091	1	PC	RMGCFMIC 100K0 OHM +5% 62MI5W
R282	1013534091	1	PC	RMGCFMIC 100K0 OHM +5% 62MI5W
R283	1013595091	1	PC	RMGCFMIC 5K1 OHM +5% 62MI5W
R284	1013491091	1	PC	RMGCFMIC 470R0 OHM +5% 62MI5W
R285	1013595091	1	PC	RMGCFMIC 5K1 OHM +5% 62MI5W
R286	1013577091	1	PC	RMGCFMIC 1K0 OHM +5% 62MI5W
R287	1013534091	1	PC	RMGCFMIC 100K0 OHM +5% 62MI5W
R288	1013474091	1	PC	RMGCFMIC 100R0 OHM +5% 62MI5W
R289	1013534091	1	PC	RMGCFMIC 100K0 OHM +5% 62MI5W
R292	1013586091	1	PC	RMGCFMIC 2K2 OHM +5% 62MI5W
R293	1013577091	1	PC	RMGCFMIC 1K0 OHM +5% 62MI5W
R294	1013585091	1	PC	RMGCFMIC 2K0 OHM +5% 62MI5W
R298	1013586091	1	PC	RMGCFMIC 2K2 OHM +5% 62MI5W
R301	1013577091	1	PC	RMGCFMIC 1K0 OHM +5% 62MI5W
R302	1013585091	1	PC	RMGCFMIC 2K0 OHM +5% 62MI5W
R303	1013577091	1	PC	RMGCFMIC 1K0 OHM +5% 62MI5W
R305	1013534091	1	PC	RMGCFMIC 100K0 OHM +5% 62MI5W
R306	1013534091	1	PC	RMGCFMIC 100K0 OHM +5% 62MI5W
R307	1013595091	1	PC	RMGCFMIC 5K1 OHM +5% 62MI5W
R308	1013534091	1	PC	RMGCFMIC 100K0 OHM +5% 62MI5W

Ref Designator	Part Number	Qty		Description
INPUT/PROCESSOR PCB				
R309	1013595091	1	PC	RMGCFMIC 5K1 OHM +5% 62MI5W
R310	1013577091	1	PC	RMGCFMIC 1K0 OHM +5% 62MI5W
R311	1013534091	1	PC	RMGCFMIC 100K0 OHM +5% 62MI5W
R312	1013595091	1	PC	RMGCFMIC 5K1 OHM +5% 62MI5W
R313	1013534091	1	PC	RMGCFMIC 100K0 OHM +5% 62MI5W
R319	1013534091	1	PC	RMGCFMIC 100K0 OHM +5% 62MI5W
R320	1013577091	1	PC	RMGCFMIC 1K0 OHM +5% 62MI5W
R321	1013517091	1	PC	RMGCFMIC 33K0 OHM +5% 62MI5W
R324	1013577091	1	PC	RMGCFMIC 1K0 OHM +5% 62MI5W
R325	1013577091	1	PC	RMGCFMIC 1K0 OHM +5% 62MI5W
R326	1013577091	1	PC	RMGCFMIC 1K0 OHM +5% 62MI5W
R327	1013586091	1	PC	RMGCFMIC 2K2 OHM +5% 62MI5W
R329	1013577091	1	PC	RMGCFMIC 1K0 OHM +5% 62MI5W
R332	1013517091	1	PC	RMGCFMIC 33K0 OHM +5% 62MI5W
R335	1013491091	1	PC	RMGCFMIC 470R0 OHM +5% 62MI5W
R336	1013586091	1	PC	RMGCFMIC 2K2 OHM +5% 62MI5W
R337	1013586091	1	PC	RMGCFMIC 2K2 OHM +5% 62MI5W
R343	1013577091	1	PC	RMGCFMIC 1K0 OHM +5% 62MI5W
R344	1013577091	1	PC	RMGCFMIC 1K0 OHM +5% 62MI5W
R345	1013577091	1	PC	RMGCFMIC 1K0 OHM +5% 62MI5W
R346	1013577091	1	PC	RMGCFMIC 1K0 OHM +5% 62MI5W
R347	1013577091	1	PC	RMGCFMIC 1K0 OHM +5% 62MI5W
R348	1013577091	1	PC	RMGCFMIC 1K0 OHM +5% 62MI5W
R349	1013577091	1	PC	RMGCFMIC 1K0 OHM +5% 62MI5W
R350	1013577091	1	PC	RMGCFMIC 1K0 OHM +5% 62MI5W
R351	1013587091	1	PC	RMGCFMIC 2K4 OHM +5% 62MI5W
R352	1013587091	1	PC	RMGCFMIC 2K4 OHM +5% 62MI5W
R353	1013491091	1	PC	RMGCFMIC 470R0 OHM +5% 62MI5W
R354	1013491091	1	PC	RMGCFMIC 470R0 OHM +5% 62MI5W
R355	1013491091	1	PC	RMGCFMIC 470R0 OHM +5% 62MI5W
R356	1013491091	1	PC	RMGCFMIC 470R0 OHM +5% 62MI5W
R357	1013491091	1	PC	RMGCFMIC 470R0 OHM +5% 62MI5W
R358	1013491091	1	PC	RMGCFMIC 470R0 OHM +5% 62MI5W
R359	1013491091	1	PC	RMGCFMIC 470R0 OHM +5% 62MI5W
R360	1013491091	1	PC	RMGCFMIC 470R0 OHM +5% 62MI5W
R361	1013491091	1	PC	RMGCFMIC 470R0 OHM +5% 62MI5W
R362	1013491091	1	PC	RMGCFMIC 470R0 OHM +5% 62MI5W
R363	1013491091	1	PC	RMGCFMIC 470R0 OHM +5% 62MI5W
R364	1013491091	1	PC	RMGCFMIC 470R0 OHM +5% 62MI5W
R365	1013491091	1	PC	RMGCFMIC 470R0 OHM +5% 62MI5W
R366	1013491091	1	PC	RMGCFMIC 470R0 OHM +5% 62MI5W
R367	1013491091	1	PC	RMGCFMIC 470R0 OHM +5% 62MI5W
R368	1013491091	1	PC	RMGCFMIC 470R0 OHM +5% 62MI5W
R369	1013491091	1	PC	RMGCFMIC 470R0 OHM +5% 62MI5W
R370	1013491091	1	PC	RMGCFMIC 470R0 OHM +5% 62MI5W
R371	1013491091	1	PC	RMGCFMIC 470R0 OHM +5% 62MI5W
R372	1013491091	1	PC	RMGCFMIC 470R0 OHM +5% 62MI5W
R373	1013491091	1	PC	RMGCFMIC 470R0 OHM +5% 62MI5W
R374	1013491091	1	PC	RMGCFMIC 470R0 OHM +5% 62MI5W
R375	1013491091	1	PC	RMGCFMIC 470R0 OHM +5% 62MI5W
R401	1013577091	1	PC	RMGCFMIC 1K0 OHM +5% 62MI5W
R402	1013577091	1	PC	RMGCFMIC 1K0 OHM +5% 62MI5W
R409	1013491091	1	PC	RMGCFMIC 470R0 OHM +5% 62MI5W
R410	1013491091	1	PC	RMGCFMIC 470R0 OHM +5% 62MI5W
R411	1013474091	1	PC	RMGCFMIC 100R0 OHM +5% 62MI5W
J023	1032875091	1	PC	RMGCFMIC 0 OHM +0% 62MI5W
J024	1032875091	1	PC	RMGCFMIC 0 OHM +0% 62MI5W
J025	1032875091	1	PC	RMGCFMIC 0 OHM +0% 62MI5W
R007	1013586091	1	PC	RMGCFMIC 2K2 OHM +5% 62MI5W
R008	1013586091	1	PC	RMGCFMIC 2K2 OHM +5% 62MI5W
R019	1013517091	1	PC	RMGCFMIC 33K0 OHM +5% 62MI5W
R023	1013586091	1	PC	RMGCFMIC 2K2 OHM +5% 62MI5W
R024	1013586091	1	PC	RMGCFMIC 2K2 OHM +5% 62MI5W
R037	1013586091	1	PC	RMGCFMIC 2K2 OHM +5% 62MI5W
R038	1013586091	1	PC	RMGCFMIC 2K2 OHM +5% 62MI5W
R053	1013586091	1	PC	RMGCFMIC 2K2 OHM +5% 62MI5W
R054	1013586091	1	PC	RMGCFMIC 2K2 OHM +5% 62MI5W

Ref Designator	Part Number	Qty		Description
INPUT/PROCESSOR PCB				
R055	1013517091	1	PC	RMGCFMIC 33K0 OHM +5% 62MI5W
R083	1013517091	1	PC	RMGCFMIC 33K0 OHM +5% 62MI5W
R084	1013517091	1	PC	RMGCFMIC 33K0 OHM +5% 62MI5W
R087	1013517091	1	PC	RMGCFMIC 33K0 OHM +5% 62MI5W
R122	1013577091	1	PC	RMGCFMIC 1K0 OHM +5% 62MI5W
R125	1013577091	1	PC	RMGCFMIC 1K0 OHM +5% 62MI5W
R135	1013503091	1	PC	RMGCFMIC 12K0 OHM +5% 62MI5W
R156	1013590091	1	PC	RMGCFMIC 3K3 OHM +5% 62MI5W
R157	1013590091	1	PC	RMGCFMIC 3K3 OHM +5% 62MI5W
R158	1013503091	1	PC	RMGCFMIC 12K0 OHM +5% 62MI5W
R159	1013590091	1	PC	RMGCFMIC 3K3 OHM +5% 62MI5W
R160	1013590091	1	PC	RMGCFMIC 3K3 OHM +5% 62MI5W
R197	1013465091	1	PC	RMGCFMIC 47R0 OHM +5% 62MI5W
R201	1013465091	1	PC	RMGCFMIC 47R0 OHM +5% 62MI5W
R208	1013441091	1	PC	RMGCFMIC 10R0 OHM +5% 62MI5W
R209	1013441091	1	PC	RMGCFMIC 10R0 OHM +5% 62MI5W
R210	1013586091	1	PC	RMGCFMIC 2K2 OHM +5% 62MI5W
R211	1013553091	1	PC	RMGCFMIC 470K0 OHM +5% 62MI5W
R213	1013586091	1	PC	RMGCFMIC 2K2 OHM +5% 62MI5W
R214	1013508091	1	PC	RMGCFMIC 18K0 OHM +5% 62MI5W
R217	1013586091	1	PC	RMGCFMIC 2K2 OHM +5% 62MI5W
R218	1013586091	1	PC	RMGCFMIC 2K2 OHM +5% 62MI5W
R219	1013517091	1	PC	RMGCFMIC 33K0 OHM +5% 62MI5W
R223	1013508091	1	PC	RMGCFMIC 18K0 OHM +5% 62MI5W
R224	1013586091	1	PC	RMGCFMIC 2K2 OHM +5% 62MI5W
R227	1013553091	1	PC	RMGCFMIC 470K0 OHM +5% 62MI5W
R228	1013586091	1	PC	RMGCFMIC 2K2 OHM +5% 62MI5W
R232	1013474091	1	PC	RMGCFMIC 100R0 OHM +5% 62MI5W
R242	1013474091	1	PC	RMGCFMIC 100R0 OHM +5% 62MI5W
R243	1013474091	1	PC	RMGCFMIC 100R0 OHM +5% 62MI5W
R253	1013474091	1	PC	RMGCFMIC 100R0 OHM +5% 62MI5W
R257	1013586091	1	PC	RMGCFMIC 2K2 OHM +5% 62MI5W
R258	1013553091	1	PC	RMGCFMIC 470K0 OHM +5% 62MI5W
R261	1013586091	1	PC	RMGCFMIC 2K2 OHM +5% 62MI5W
R262	1013508091	1	PC	RMGCFMIC 18K0 OHM +5% 62MI5W
R265	1013517091	1	PC	RMGCFMIC 33K0 OHM +5% 62MI5W
R266	1013517091	1	PC	RMGCFMIC 33K0 OHM +5% 62MI5W
R267	1013517091	1	PC	RMGCFMIC 33K0 OHM +5% 62MI5W
R271	1013508091	1	PC	RMGCFMIC 18K0 OHM +5% 62MI5W
R272	1013586091	1	PC	RMGCFMIC 2K2 OHM +5% 62MI5W
R275	1013553091	1	PC	RMGCFMIC 470K0 OHM +5% 62MI5W
R276	1013586091	1	PC	RMGCFMIC 2K2 OHM +5% 62MI5W
R280	1013474091	1	PC	RMGCFMIC 100R0 OHM +5% 62MI5W
R290	1013474091	1	PC	RMGCFMIC 100R0 OHM +5% 62MI5W
R291	1013517091	1	PC	RMGCFMIC 33K0 OHM +5% 62MI5W
R295	1013508091	1	PC	RMGCFMIC 18K0 OHM +5% 62MI5W
R296	1013586091	1	PC	RMGCFMIC 2K2 OHM +5% 62MI5W
R299	1013553091	1	PC	RMGCFMIC 470K0 OHM +5% 62MI5W
R300	1013586091	1	PC	RMGCFMIC 2K2 OHM +5% 62MI5W
R304	1013474091	1	PC	RMGCFMIC 100R0 OHM +5% 62MI5W
R314	1013474091	1	PC	RMGCFMIC 100R0 OHM +5% 62MI5W
R315	1013441091	1	PC	RMGCFMIC 10R0 OHM +5% 62MI5W
R316	1013441091	1	PC	RMGCFMIC 10R0 OHM +5% 62MI5W
R317	1013586091	1	PC	RMGCFMIC 2K2 OHM +5% 62MI5W
R318	1013586091	1	PC	RMGCFMIC 2K2 OHM +5% 62MI5W
R322	1013505091	1	PC	RMGCFMIC 15K0 OHM +5% 62MI5W
R323	1013505091	1	PC	RMGCFMIC 15K0 OHM +5% 62MI5W
R330	1013586091	1	PC	RMGCFMIC 2K2 OHM +5% 62MI5W
R333	1013586091	1	PC	RMGCFMIC 2K2 OHM +5% 62MI5W
<i>Miscellaneous</i>				
N302	556865000	1	PC	WIRECONASY UNIQUE 15P 180MM UL1533 SHIELD 26 1
NJ51	55176330	1	PC	CON PHONO SCKT RCA 4P JW4104RS GND
NJ52	55176330	1	PC	CON PHONO SCKT RCA 4P JW4104RS GND
NJ53	55176330	1	PC	CON PHONO SCKT RCA 4P JW4104RS GND
NJ54	55176330	1	PC	CON PHONO SCKT RCA 4P JW4104RS GND

Ref Designator	Part Number	Qty		Description
INPUT/PROCESSOR PCB				
NJ55	55176330	1	PC	CON PHONO SCKT RCA 4P JW4104RS GND
NJ56	55426050NR	1	PC	JACK-TELE SNAP-IN GOLDEN TELECOM GDL1-8P8C 8T BK 0 0
P301	55174630	1	PC	CONN 2.0MM 19 MA ST NAT MOLEX 35336-1910 0 0
P303	55125070	1	PC	CONN 2.0MM 15 MA R NAT MOLEX 35237-1510 0 0
P304	55230480	1	PC	CONN 1.25MM 31 FE ST BK 00-6216-131-821-808 0 0
P305	55125070	1	PC	CONN 2.0MM 15 MA R NAT MOLEX 35237-1510 0 0
P306	55174670	1	PC	CONN 2.0MM 19 MA R NAT SOCKET MOLEX 35237-1910 0 0
P307	55090080	1	PC	CONN 2.0MM 3 MA ST NAT LW2002P03 0 0
P308	55090050	1	PC	CONN 2.0MM 10 MA ST NAT LW2002P10 0 0
P401	55146620	1	PC	CONN 2.5MM 7 MA ST NAT 0 0
P402	55146590	1	PC	CONN 2.5MM 5 MA ST NAT 0 0
P403	55146580	1	PC	CONN 2.5MM 4 MA ST NAT 0 0
P404	55146610	1	PC	CONN 2.5MM 6 MA ST NAT 0 0
P405	55146590	1	PC	CONN 2.5MM 5 MA ST NAT 0 0
P406	55146580	1	PC	CONN 2.5MM 4 MA ST NAT 0 0
P407	55146570	1	PC	CONN 2.5MM 3 MA ST NAT 0 0
SK01	55506590NR	1	PC	RELAYSGNL 12.0V 960.0OHM 3.0A
CONNECTOR PCB				
P401	55174630	1	PC	CONN 2.0MM 19 MA ST NAT MOLEX 35336-1910 0 0
P402	55125010	1	PC	CONN 2.0MM 15 MA ST NAT MOLEX 35336-1510 0 0
P403	55174620	1	PC	CONN 2.0MM 17 MA ST NAT MOLEX 35336-1710 0 0
P404	55174670	1	PC	CONN 2.0MM 19 MA R NAT SOCKET MOLEX 35237-1910 0 0
P405	55125010	1	PC	CONN 2.0MM 15 MA ST NAT MOLEX 35336-1510 0 0
P406	55171520	1	PC	CONN 2.0MM 5 MA ST NAT MOLEX 35336-0510 0 0
P407	55125030	1	PC	CONN 2.0MM 11 MA R NAT MOLEX 35237-1110 0 0
P408	55174630	1	PC	CONN 2.0MM 19 MA ST NAT MOLEX 35336-1910 0 0
P409	55174670	1	PC	CONN 2.0MM 19 MA R NAT SOCKET MOLEX 35237-1910 0 0
P410	55174630	1	PC	CONN 2.0MM 19 MA ST NAT MOLEX 35336-1910 0 0
P411	55174670	1	PC	CONN 2.0MM 19 MA R NAT SOCKET MOLEX 35237-1910 0 0
J401	20441210	1	PC	BCL 0.5MM TIN ANNEALED COPPER 20.0MM 8MM FIG 1 20322610
J402	20441210	1	PC	BCL 0.5MM TIN ANNEALED COPPER 20.0MM 8MM FIG 1 20322610
VIDEO PCB				
<i>Capacitors</i>				
C112	2050659091	1	PC	CCCFMIC 100POF +5% -5% 50.0V NP0
C113	2050659091	1	PC	CCCFMIC 100POF +5% -5% 50.0V NP0
C114	2050659091	1	PC	CCCFMIC 100POF +5% -5% 50.0V NP0
C118	2050659091	1	PC	CCCFMIC 100POF +5% -5% 50.0V NP0
C119	2050659091	1	PC	CCCFMIC 100POF +5% -5% 50.0V NP0
C120	2050659091	1	PC	CCCFMIC 100POF +5% -5% 50.0V NP0
C123	2050668091	1	PC	CCCFMIC 470POF +5% -5% 50.0V NP0
C124	2050659091	1	PC	CCCFMIC 100POF +5% -5% 50.0V NP0
C125	2050659091	1	PC	CCCFMIC 100POF +5% -5% 50.0V NP0
C126	2050659091	1	PC	CCCFMIC 100POF +5% -5% 50.0V NP0
C148	2028804091	1	PC	CCCFMIC 100NOF +80% -20% 16.0V Y5V
C150	2028804091	1	PC	CCCFMIC 100NOF +80% -20% 16.0V Y5V
C154	2028804091	1	PC	CCCFMIC 100NOF +80% -20% 16.0V Y5V
C155	2050659091	1	PC	CCCFMIC 100POF +5% -5% 50.0V NP0
C156	2050659091	1	PC	CCCFMIC 100POF +5% -5% 50.0V NP0
C157	2050659091	1	PC	CCCFMIC 100POF +5% -5% 50.0V NP0
C158	2050659091	1	PC	CCCFMIC 100POF +5% -5% 50.0V NP0
C159	2050659091	1	PC	CCCFMIC 100POF +5% -5% 50.0V NP0
C160	2050659091	1	PC	CCCFMIC 100POF +5% -5% 50.0V NP0
C162	2028804091	1	PC	CCCFMIC 100NOF +80% -20% 16.0V Y5V
C163	2050654091	1	PC	CCCFMIC 10P0F +0P5F -0P5F 50.0V NP0
C167	1013862091	1	PC	CCCFMIC 2N2F +10% -10% 50.0V X7R
C169	2050659091	1	PC	CCCFMIC 100POF +5% -5% 50.0V NP0
C170	1013839091	1	PC	CCCFMIC 560POF +10% -10% 50.0V X7R
C173	1013896091	1	PC	CCCFMIC 10N0F +10% -10% 50.0V X7R
C177	2050656091	1	PC	CCCFMIC 33P0F +5% -5% 50.0V NP0
C178	2050659091	1	PC	CCCFMIC 100POF +5% -5% 50.0V NP0
C180	2050659091	1	PC	CCCFMIC 100POF +5% -5% 50.0V NP0
C181	1013896091	1	PC	CCCFMIC 10N0F +10% -10% 50.0V X7R

Ref Designator	Part Number	Qty		Description
VIDEO PCB				
C187	1013896091	1	PC	CCCFMIC 10N0F +10% -10% 50.0V X7R
C189	2028804091	1	PC	CCCFMIC 100N0F +80% -20% 16.0V Y5V
C191	2028804091	1	PC	CCCFMIC 100N0F +80% -20% 16.0V Y5V
C193	2028804091	1	PC	CCCFMIC 100N0F +80% -20% 16.0V Y5V
C195	2028804091	1	PC	CCCFMIC 100N0F +80% -20% 16.0V Y5V
C197	1013896091	1	PC	CCCFMIC 10N0F +10% -10% 50.0V X7R
C200	2067807091	1	PC	CCCFMIC 330P0F +5% -5% 50.0V NP0
C248	2028804091	1	PC	CCCFMIC 100N0F +80% -20% 16.0V Y5V
C292	2028804091	1	PC	CCCFMIC 100N0F +80% -20% 16.0V Y5V
C294	2028804091	1	PC	CCCFMIC 100N0F +80% -20% 16.0V Y5V
C311	2028804091	1	PC	CCCFMIC 100N0F +80% -20% 16.0V Y5V
C315	2028804091	1	PC	CCCFMIC 100N0F +80% -20% 16.0V Y5V
C100	2026908030	1	PC	CE 220U0F +20% 10.0V 85C
C101	1500213030	1	PC	CE 10U0F +20% 16.0V 85C
C102	2026908030	1	PC	CE 220U0F +20% 10.0V 85C
C103	2026908030	1	PC	CE 220U0F +20% 10.0V 85C
C104	1500213030	1	PC	CE 10U0F +20% 16.0V 85C
C105	2026908030	1	PC	CE 220U0F +20% 10.0V 85C
C106	2026908030	1	PC	CE 220U0F +20% 10.0V 85C
C107	1500213030	1	PC	CE 10U0F +20% 16.0V 85C
C108	2026908030	1	PC	CE 220U0F +20% 10.0V 85C
C109	2026908030	1	PC	CE 220U0F +20% 10.0V 85C
C110	1500213030	1	PC	CE 10U0F +20% 16.0V 85C
C111	2026908030	1	PC	CE 220U0F +20% 10.0V 85C
C115	2026783030	1	PC	CE 47U0F +20% 16.0V 85C 20251640
C116	1500213030	1	PC	CE 10U0F +20% 16.0V 85C
C117	2026783030	1	PC	CE 47U0F +20% 16.0V 85C 20251640
C121	1500213030	1	PC	CE 10U0F +20% 16.0V 85C
C122	1500213030	1	PC	CE 10U0F +20% 16.0V 85C
C128	2026884030	1	PC	CE 1U0F +20% 50.0V 85C
C130	2025267030	1	PC	CE 470U0F +20% 10.0V 85C
C131	2025267030	1	PC	CE 470U0F +20% 10.0V 85C
C132	2025267030	1	PC	CE 470U0F +20% 10.0V 85C
C133	2025267030	1	PC	CE 470U0F +20% 10.0V 85C
C134	2025267030	1	PC	CE 470U0F +20% 10.0V 85C
C135	2025267030	1	PC	CE 470U0F +20% 10.0V 85C
C136	2026908030	1	PC	CE 220U0F +20% 10.0V 85C
C137	1500213030	1	PC	CE 10U0F +20% 16.0V 85C
C138	2026908030	1	PC	CE 220U0F +20% 10.0V 85C
C139	2026908030	1	PC	CE 220U0F +20% 10.0V 85C
C140	2026908030	1	PC	CE 220U0F +20% 10.0V 85C
C141	2026783030	1	PC	CE 47U0F +20% 16.0V 85C 20251640
C145	2025267030	1	PC	CE 470U0F +20% 10.0V 85C
C146	2025267030	1	PC	CE 470U0F +20% 10.0V 85C
C147	2025267030	1	PC	CE 470U0F +20% 10.0V 85C
C149	2025267030	1	PC	CE 470U0F +20% 10.0V 85C
C151	2026902030	1	PC	CE 100U0F +20% 16.0V 85C
C152	2026908030	1	PC	CE 220U0F +20% 10.0V 85C
C153	2026783030	1	PC	CE 47U0F +20% 16.0V 85C 20251640
C161	2026783030	1	PC	CE 47U0F +20% 16.0V 85C 20251640
C164	2026884030	1	PC	CE 1U0F +20% 50.0V 85C
C165	2026896030	1	PC	CE 330N0F +20% 50.0V 85C
C166	2026884030	1	PC	CE 1U0F +20% 50.0V 85C
C168	2026894030	1	PC	CE 100U0F +20% 10.0V 85C
C171	8043459071	1	PC	CC 22P0F +5% -5% 50.0V NP0
C172	2026894030	1	PC	CE 100U0F +20% 10.0V 85C
C174	8043459071	1	PC	CC 22P0F +5% -5% 50.0V NP0
C175	4043335071	1	PC	CC 18P0F +5% -5% 50.0V NP0
C176	2026884030	1	PC	CE 1U0F +20% 50.0V 85C
C183	7042852071	1	PC	CC 10N0F +10% -10% 50.0V Y5P
C184	2026885039	1	PC	CE 2U2F +20% 50.0V 85C
C185	2026888030	1	PC	CE 10U0F +20% 50.0V 85C
C186	2026894030	1	PC	CE 100U0F +20% 10.0V 85C
C188	2026902030	1	PC	CE 100U0F +20% 16.0V 85C
C190	2026902030	1	PC	CE 100U0F +20% 16.0V 85C
C192	2026902030	1	PC	CE 100U0F +20% 16.0V 85C
C194	2026902030	1	PC	CE 100U0F +20% 16.0V 85C

Ref Designator	Part Number	Qty		Description
VIDEO PCB				
C196	2026894030	1	PC	CE 100U0F +20% 10.0V 85C
C198	2026888030	1	PC	CE 10U0F +20% 50.0V 85C
C199	2026908030	1	PC	CE 220U0F +20% 10.0V 85C
C201	2026885030	1	PC	CE 2U2F +20% 50.0V 85C
C202	2026725071	1	PC	CC 22N0F +10% -10% 50.0V Z5R
C203	2026908030	1	PC	CE 220U0F +20% 10.0V 85C
C204	1500213030	1	PC	CE 10U0F +20% 16.0V 85C
C205	2026908030	1	PC	CE 220U0F +20% 10.0V 85C
C206	1500213030	1	PC	CE 10U0F +20% 16.0V 85C
C289	2026908030	1	PC	CE 220U0F +20% 10.0V 85C
C291	2026902030	1	PC	CE 100U0F +20% 16.0V 85C
C293	2026902030	1	PC	CE 100U0F +20% 16.0V 85C
C295	2026908030	1	PC	CE 220U0F +20% 10.0V 85C
C313	2026783030	1	PC	CE 47U0F +20% 16.0V 85C 20251640
<i>Semiconductors</i>				
IC18	20361320MU	1	PC	IC-REGPOSFXD KIA7806PI NORMAL
IC21	404404400	1	PC	IC-LIN BA7046 2856 A0 00
IC22	55179610MU	1	PC	IC-SPECFUNC M35013 OSD
IC28	551239700	1	PC	IC-REGPOSFXD KIA7808API NORMAL
D106	2049651085	1	PC	D-SLP 1SS355 35.0V 225MIOA
D107	2049651085	1	PC	D-SLP 1SS355 35.0V 225MIOA
D109	2049651085	1	PC	D-SLP 1SS355 35.0V 225MIOA
D110	2049651085	1	PC	D-SLP 1SS355 35.0V 225MIOA
IC10	55125370MT	1	PC	IC-SWITCH NJM2296 SOP16 VIDEO
IC11	55125370MT	1	PC	IC-SWITCH NJM2296 SOP16 VIDEO
IC12	55125370MT	1	PC	IC-SWITCH NJM2296 SOP16 VIDEO
IC13	55489850MT	1	PC	IC-VIDEOPROC MM1505XNRE AMPLIFIER&DRIVER
IC14	55489680MT	1	PC	IC-VIDEOPROC MM1501XNRE AMPLIFIER&DRIVER
IC15	55489850MT	1	PC	IC-VIDEOPROC MM1505XNRE AMPLIFIER&DRIVER
IC16	20718770MT	1	PC	IC-LOGIC BU4053BF MULTIPLEXER CMOS
IC17	55175530MU	1	PC	IC-VIDEOPROC TSH95ID VIDEO AMPLIFIER
IC19	20718660MT	1	PC	IC-LOGIC BU4094BF SHIFT REGISTER CMOS
IC20	20718660MT	1	PC	IC-LOGIC BU4094BF SHIFT REGISTER CMOS
IC23	55489850MT	1	PC	IC-VIDEOPROC MM1505XNRE AMPLIFIER&DRIVER
IC25	55489680MT	1	PC	IC-VIDEOPROC MM1501XNRE AMPLIFIER&DRIVER
IC26	55489680MT	1	PC	IC-VIDEOPROC MM1501XNRE AMPLIFIER&DRIVER
IC27	55489750MT	1	PC	IC-VIDEOPROC MM1511XNRE AMPLIFIER&DRIVER
Q102	5513319092	1	PC	TR-SSD DTA114YKA P 10K0 OHM 47K0 OHM
Q103	5513319092	1	PC	TR-SSD DTA114YKA P 10K0 OHM 47K0 OHM
Q100	5513325056	1	PC	TR-SLPLF 2SC1740S R N 150MIOA 50V
Q101	5510193056	1	PC	TR-SLPLF 2SA933ASR P -3.0A -20V
Q104	5510193056	1	PC	TR-SLPLF 2SA933ASR P -3.0A -20V
Q105	5513321056	1	PC	TR-SLPLF DTC114YSA N 100MIOA
Q107	5513321056	1	PC	TR-SLPLF DTC114YSA N 100MIOA
Q110	5513321056	1	PC	TR-SLPLF DTC114YSA N 100MIOA
Q111	5510193056	1	PC	TR-SLPLF 2SA933ASR P -3.0A -20V
Q112	5513325056	1	PC	TR-SLPLF 2SC1740S R N 150MIOA 50V
D102	7043654016	1	PC	D-SLP 1N4148 100.0V 150E-3A
D104	7043654016	1	PC	D-SLP 1N4148 100.0V 150E-3A
D115	7043654016	1	PC	D-SLP 1N4148 100.0V 150E-3A
<i>Resistors</i>				
R100	1013471091	1	PC	RMGCFMIC 75R0 OHM +5% 62MI5W
R101	1013470091	1	PC	RMGCFMIC 68R0 OHM +5% 62MI5W
R102	1013471091	1	PC	RMGCFMIC 75R0 OHM +5% 62MI5W
R103	1013471091	1	PC	RMGCFMIC 75R0 OHM +5% 62MI5W
R104	1013470091	1	PC	RMGCFMIC 68R0 OHM +5% 62MI5W
R105	1013471091	1	PC	RMGCFMIC 75R0 OHM +5% 62MI5W
R106	1013471091	1	PC	RMGCFMIC 75R0 OHM +5% 62MI5W
R107	1013470091	1	PC	RMGCFMIC 68R0 OHM +5% 62MI5W
R108	1013471091	1	PC	RMGCFMIC 75R0 OHM +5% 62MI5W
R109	1013471091	1	PC	RMGCFMIC 75R0 OHM +5% 62MI5W
R110	1013470091	1	PC	RMGCFMIC 68R0 OHM +5% 62MI5W
R111	1013471091	1	PC	RMGCFMIC 75R0 OHM +5% 62MI5W

Ref Designator	Part Number	Qty		Description
VIDEO PCB				
R112	1013501091	1	PC	RMGCFMIC 10K0 OHM +5% 62MI5W
R113	1013501091	1	PC	RMGCFMIC 10K0 OHM +5% 62MI5W
R114	1013501091	1	PC	RMGCFMIC 10K0 OHM +5% 62MI5W
R115	1013471091	1	PC	RMGCFMIC 75R0 OHM +5% 62MI5W
R116	1013470091	1	PC	RMGCFMIC 68R0 OHM +5% 62MI5W
R117	1013471091	1	PC	RMGCFMIC 75R0 OHM +5% 62MI5W
R118	1013501091	1	PC	RMGCFMIC 10K0 OHM +5% 62MI5W
R119	1013501091	1	PC	RMGCFMIC 10K0 OHM +5% 62MI5W
R120	1013501091	1	PC	RMGCFMIC 10K0 OHM +5% 62MI5W
R121	1013471091	1	PC	RMGCFMIC 75R0 OHM +5% 62MI5W
R122	1013470091	1	PC	RMGCFMIC 68R0 OHM +5% 62MI5W
R123	1013471091	1	PC	RMGCFMIC 75R0 OHM +5% 62MI5W
R124	1013501091	1	PC	RMGCFMIC 10K0 OHM +5% 62MI5W
R125	1013501091	1	PC	RMGCFMIC 10K0 OHM +5% 62MI5W
R126	1013501091	1	PC	RMGCFMIC 10K0 OHM +5% 62MI5W
R127	1013470091	1	PC	RMGCFMIC 68R0 OHM +5% 62MI5W
R128	1013470091	1	PC	RMGCFMIC 68R0 OHM +5% 62MI5W
R129	1013470091	1	PC	RMGCFMIC 68R0 OHM +5% 62MI5W
R130	1013577091	1	PC	RMGCFMIC 1K0 OHM +5% 62MI5W
R131	1013577091	1	PC	RMGCFMIC 1K0 OHM +5% 62MI5W
R132	1013577091	1	PC	RMGCFMIC 1K0 OHM +5% 62MI5W
R133	1013577091	1	PC	RMGCFMIC 1K0 OHM +5% 62MI5W
R134	1013577091	1	PC	RMGCFMIC 1K0 OHM +5% 62MI5W
R135	1013577091	1	PC	RMGCFMIC 1K0 OHM +5% 62MI5W
R136	1013487091	1	PC	RMGCFMIC 330R0 OHM +5% 62MI5W
R137	2541927091	1	PC	RMGCFMIC 162R0 OHM +1% 62MI5W
R138	1013478091	1	PC	RMGCFMIC 150R0 OHM +5% 62MI5W
R139	1013512091	1	PC	RMGCFMIC 22K0 OHM +5% 62MI5W
R140	1013512091	1	PC	RMGCFMIC 22K0 OHM +5% 62MI5W
R141	1013512091	1	PC	RMGCFMIC 22K0 OHM +5% 62MI5W
R142	1013501091	1	PC	RMGCFMIC 10K0 OHM +5% 62MI5W
R143	1013501091	1	PC	RMGCFMIC 10K0 OHM +5% 62MI5W
R144	1013501091	1	PC	RMGCFMIC 10K0 OHM +5% 62MI5W
R145	1013501091	1	PC	RMGCFMIC 10K0 OHM +5% 62MI5W
R146	1013503091	1	PC	RMGCFMIC 12K0 OHM +5% 62MI5W
R147	1013503091	1	PC	RMGCFMIC 12K0 OHM +5% 62MI5W
R148	1013577091	1	PC	RMGCFMIC 1K0 OHM +5% 62MI5W
R149	1013553091	1	PC	RMGCFMIC 470K0 OHM +5% 62MI5W
R150	1013501091	1	PC	RMGCFMIC 10K0 OHM +5% 62MI5W
R151	1013553091	1	PC	RMGCFMIC 470K0 OHM +5% 62MI5W
R152	1013562091	1	PC	RMGCFMIC 1M0 OHM +10% 62MI5W
R153	1013538091	1	PC	RMGCFMIC 150K0 OHM +5% 62MI5W
R154	1013538091	1	PC	RMGCFMIC 150K0 OHM +5% 62MI5W
R155	1013562091	1	PC	RMGCFMIC 1M0 OHM +10% 62MI5W
R156	1013491091	1	PC	RMGCFMIC 470R0 OHM +5% 62MI5W
R158	1013542091	1	PC	RMGCFMIC 220K0 OHM +5% 62MI5W
R159	1013598091	1	PC	RMGCFMIC 6K8 OHM +5% 62MI5W
R160	1013586091	1	PC	RMGCFMIC 2K2 OHM +5% 62MI5W
R161	1013577091	1	PC	RMGCFMIC 1K0 OHM +5% 62MI5W
R162	1013577091	1	PC	RMGCFMIC 1K0 OHM +5% 62MI5W
R163	1013577091	1	PC	RMGCFMIC 1K0 OHM +5% 62MI5W
R165	1013474091	1	PC	RMGCFMIC 100R0 OHM +5% 62MI5W
R166	1013517091	1	PC	RMGCFMIC 33K0 OHM +5% 62MI5W
R167	1013586091	1	PC	RMGCFMIC 2K2 OHM +5% 62MI5W
R168	1013470091	1	PC	RMGCFMIC 68R0 OHM +5% 62MI5W
R169	1013600091	1	PC	RMGCFMIC 8K2 OHM +5% 62MI5W
R171	1013538091	1	PC	RMGCFMIC 150K0 OHM +5% 62MI5W
R172	1013517091	1	PC	RMGCFMIC 33K0 OHM +5% 62MI5W
R173	1013586091	1	PC	RMGCFMIC 2K2 OHM +5% 62MI5W
R174	1013470091	1	PC	RMGCFMIC 68R0 OHM +5% 62MI5W
R176	1013464091	1	PC	RMGCFMIC 43R0 OHM +5% 62MI5W
R177	1013500091	1	PC	RMGCFMIC 910R0 OHM +5% 62MI5W
R180	1013492091	1	PC	RMGCFMIC 510R0 OHM +5% 62MI5W
R181	1013487091	1	PC	RMGCFMIC 330R0 OHM +5% 62MI5W
R182	1013471091	1	PC	RMGCFMIC 75R0 OHM +5% 62MI5W
R183	1013577091	1	PC	RMGCFMIC 1K0 OHM +5% 62MI5W
R185	1013472091	1	PC	RMGCFMIC 82R0 OHM +5% 62MI5W

Ref Designator	Part Number	Qty		Description
VIDEO PCB				
R186	1013536091	1	PC	RMGCFMIC 120K0 OHM +5% 62MI5W
R188	1013501091	1	PC	RMGCFMIC 10K0 OHM +5% 62MI5W
R189	1013592091	1	PC	RMGCFMIC 3K9 OHM +5% 62MI5W
R200	1013485091	1	PC	RMGCFMIC 270R0 OHM +5% 62MI5W
R201	1013459091	1	PC	RMGCFMIC 33R0 OHM +5% 62MI5W
R202	1013579091	1	PC	RMGCFMIC 1K2 OHM +5% 62MI5W
<i>Miscellaneous</i>				
L103	5516884016	1	PC	LF 47U0H +10% 5.8 OHM 70MI0A
L104	5516884016	1	PC	LF 47U0H +10% 5.8 OHM 70MI0A
L105	5516884016	1	PC	LF 47U0H +10% 5.8 OHM 70MI0A
L106	5516884016	1	PC	LF 47U0H +10% 5.8 OHM 70MI0A
L107	5517935016	1	PC	LF 22U0H +10% 3.4 OHM 130.0A
L108	5517935016	1	PC	LF 22U0H +10% 3.4 OHM 130.0A
L110	5516884016	1	PC	LF 47U0H +10% 5.8 OHM 70MI0A
L111	5516884016	1	PC	LF 47U0H +10% 5.8 OHM 70MI0A
L100	5517950018	1	PC	LFBEAD 80.582OHM 100M0HZ FB-30 HC-3580
L101	5517950018	1	PC	LFBEAD 80.582OHM 100M0HZ FB-30 HC-3580
L102	5517950018	1	PC	LFBEAD 80.582OHM 100M0HZ FB-30 HC-3580
NJ91	55436080	1	PC	CON PHONO SCKT RCA 9P W/GND CAP JW-4109RS
NJ92	55149520	1	PC	CON DIN SCKT MIX SOCKET RCA-118JP1S
NJ93	55149520	1	PC	CON DIN SCKT MIX SOCKET RCA-118JP1S
NJ94	55149520	1	PC	CON DIN SCKT MIX SOCKET RCA-118JP1S
NJ95	55149520	1	PC	CON DIN SCKT MIX SOCKET RCA-118JP1S
NJ96	55149520	1	PC	CON DIN SCKT MIX SOCKET RCA-118JP1S
NJ97	55149520	1	PC	CON DIN SCKT MIX SOCKET RCA-118JP1S
NJ98	55149520	1	PC	CON DIN SCKT MIX SOCKET RCA-118JP1S
P601	55123430	1	PC	CONN 2.0MM 10 MA R NAT LW2003P10 0 0
P602	55206580	1	PC	CONN 2.0MM 5 MA R NAT BD'BD SOCKET MOLEX 35237-0510 0 0
P603	55174660	1	PC	CONN 2.0MM 17 MA R NAT SOCKET MOLEX 35237-1710 0 0
SK10	55489950NR	1	PC	RELAYPWR 5.0V 178.0OHM
SK11	55489950NR	1	PC	RELAYPWR 5.0V 178.0OHM
SK12	55489950NR	1	PC	RELAYPWR 5.0V 178.0OHM
Y100	552522500	1	PC	FILQZ 17M734475 HZ +30 PPM 30K0 OHM PARALLEL 22P0 F
Y101	551794700	1	PC	FILQZ 14M31818 HZ +30 PPM 30K0 OHM PARALLEL 22P0 F
POWER SUPPLY				
<i>Capacitors</i>				
C291	2028804091	1	PC	CCCFMIC 100N0F +80% -20% 16.0V Y5V
C292	2028804091	1	PC	CCCFMIC 100N0F +80% -20% 16.0V Y5V
C451	55095470NR	1	PC	CC 4N7F +20% -20% 250.0V Y5V
C457	55232840NR	1	PC	CE 27MIOF +20% 80.0V 85C
C458	55232840NR	1	PC	CE 27MIOF +20% 80.0V 85C
C459	55095470NR	1	PC	CC 4N7F +20% -20% 250.0V Y5V
C460	55095470NR	1	PC	CC 4N7F +20% -20% 250.0V Y5V
C461	55095460NR	1	PC	CPPMX 100N0F +20% -20%
C466	202692100	1	PC	CE 4MI7F +20% 25.0V 85C
C469	55095470NR	1	PC	CC 4N7F +20% -20% 250.0V Y5V
C470	55095470NR	1	PC	CC 4N7F +20% -20% 250.0V Y5V
C498	20268030AM	1	PC	CE 1MI0F +20% 25.0V 85C
C441	2024647071	1	PC	CC 100N0F +80% -20% 25.0V Z5V
C442	2017857071	1	PC	CC 47N0F +80% -20% 50.0V Z5V
C443	2017857071	1	PC	CC 47N0F +80% -20% 50.0V Z5V
C452	2041669070	1	PC	CPM 100N0F +20% 250.0V
C453	2041669070	1	PC	CPM 100N0F +20% 250.0V
C454	2041669070	1	PC	CPM 100N0F +20% 250.0V
C455	2041669070	1	PC	CPM 100N0F +20% 250.0V
C456	2041669070	1	PC	CPM 100N0F +20% 250.0V
C462	1036482071	1	PC	CPF 47N0F +10% 100.0V
C463	1036482071	1	PC	CPF 47N0F +10% 100.0V
C464	1036482071	1	PC	CPF 47N0F +10% 100.0V
C465	5512740030	1	PC	CE 560N0F +20% 50.0V 85C
C467	2026884030	1	PC	CE 1U0F +20% 50.0V 85C
C471	2026884030	1	PC	CE 1U0F +20% 50.0V 85C

Ref Designator	Part Number	Qty		Description
POWER SUPPLY				
C472	2026884030	1	PC	CE 1U0F +20% 50.0V 85C
C473	2025267030	1	PC	CE 470U0F +20% 10.0V 85C
C474	2026884030	1	PC	CE 1U0F +20% 50.0V 85C
C475	2026884030	1	PC	CE 1U0F +20% 50.0V 85C
C476	2026884030	1	PC	CE 1U0F +20% 50.0V 85C
C483	5509541071	1	PC	CPM 220N0F +10% 63.0V
C484	1307454030	1	PC	CE 100U0F +20% 50.0V 85C
C485	2026888030	1	PC	CE 10U0F +20% 50.0V 85C
C486	2026884030	1	PC	CE 1U0F +20% 50.0V 85C
C495	1036482071	1	PC	CPF 47N0F +10% 100.0V
C496	1036482071	1	PC	CPF 47N0F +10% 100.0V
C497	1036482071	1	PC	CPF 47N0F +10% 100.0V
C290	2029347016	1	PC	CC 100N0F +80% -20% 50.0V F
C468	2029347016	1	PC	CC 100N0F +80% -20% 50.0V F
C487	2029347016	1	PC	CC 100N0F +80% -20% 50.0V F
C491	2073760016	1	PC	CC 2N2F +80% -20% 16.0V 3F4
C492	2073760016	1	PC	CC 2N2F +80% -20% 16.0V 3F4
C493	2029347016	1	PC	CC 100N0F +80% -20% 50.0V F
C494	2029347016	1	PC	CC 100N0F +80% -20% 50.0V F
<i>Semiconductors</i>				
D451	20525530NR	1	PC	D-SR 1N4003 200.0V 1A
D452	55170630NR	1	PC	D-BRDHC BP3504WF 35.0A
D453	20525530NR	1	PC	D-SR 1N4003 200.0V 1A
D454	20525530NR	1	PC	D-SR 1N4003 200.0V 1A
D455	20525530NR	1	PC	D-SR 1N4003 200.0V 1A
D456	20525530NR	1	PC	D-SR 1N4003 200.0V 1A
D457	20525530NR	1	PC	D-SR 1N4003 200.0V 1A
D460	20525530NR	1	PC	D-SR 1N4003 200.0V 1A
D465	20525530NR	1	PC	D-SR 1N4003 200.0V 1A
D466	20525530NR	1	PC	D-SR 1N4003 200.0V 1A
D467	20525530NR	1	PC	D-SR 1N4003 200.0V 1A
D472	20525530NR	1	PC	D-SR 1N4003 200.0V 1A
D473	20525530NR	1	PC	D-SR 1N4003 200.0V 1A
D478	20525530NR	1	PC	D-SR 1N4003 200.0V 1A
D479	20525530NR	1	PC	D-SR 1N4003 200.0V 1A
IC41	20361320MU	1	PC	IC-REGPOSF XD KIA7806PI NORMAL
IC42	55142790NR	0	PC	IC-REGPOSF XD NJM2395F63 NORMAL
IC42	55702130NR	1	PC	IC-REGPOSF XD NJM2396F63 NORMAL
Q451	5514267056	1	PC	TR-SLPLF MPSA06 N 500MIOA
Q452	5514267056	1	PC	TR-SLPLF MPSA06 N 500MIOA
Q453	5514267056	1	PC	TR-SLPLF MPSA06 N 500MIOA
Q454	5514267056	1	PC	TR-SLPLF MPSA06 N 500MIOA
Q455	5514267056	1	PC	TR-SLPLF MPSA06 N 500MIOA
Q456	5514267056	1	PC	TR-SLPLF MPSA06 N 500MIOA
Q460	5513335056	1	PC	TR-SLPLF MPSA56 Y P -500MIOA -300V
D291	7043654016	1	PC	D-SLP 1N4148 100.0V 150E-3A
D292	7043654016	1	PC	D-SLP 1N4148 100.0V 150E-3A
D458	2052696016	1	PC	D-ZENER 1N5231B 5.1V 500MIOW
D459	7043654016	1	PC	D-SLP 1N4148 100.0V 150E-3A
D475	8044273016	1	PC	D-ZENER BZX55B33 33V 500MIOW
D476	2045463016	1	PC	D-ZENER 1N5239B 9.1V 500MIOW
<i>Resistors</i>				
R450	5518010016	1	PC	RA 3M3 OHM +10% 500MIOW
R451	55568350NR	1	PC	RW 40R0 OHM +5% 15.0W
R452	55568350NR	1	PC	RW 40R0 OHM +5% 15.0W
R455	150227100	1	PC	RMOF 10R0 OHM +5% 2.0W
R476	80442780NR	1	PC	RMOF 4R7 OHM +5% 2.0W
R479	110616700	1	PC	RMOF 12K0 OHM +5% 1.0W
R480	110616700	1	PC	RMOF 12K0 OHM +5% 1.0W
R316	1105964016	1	PC	RCF 1K0 OHM +5% 250MIOW
R453	4043564016	1	PC	RCF 4K7 OHM +5% 250MIOW
R454	4043564016	1	PC	RCF 4K7 OHM +5% 250MIOW
R456	1105964016	1	PC	RCF 1K0 OHM +5% 250MIOW

Ref Designator	Part Number	Qty		Description
POWER SUPPLY				
R457	3093948016	1	PC	RCF 10K0 OHM +5% 250MI0W
R458	1105964016	1	PC	RCF 1K0 OHM +5% 250MI0W
R459	9057106016	1	PC	RCF 12R0 OHM +5% 250MI0W
R460	1105956016	1	PC	RCF 33R0 OHM +5% 250MI0W
R461	1105956016	1	PC	RCF 33R0 OHM +5% 250MI0W
R462	1105956016	1	PC	RCF 33R0 OHM +5% 250MI0W
R463	5088295016	1	PC	RCF 100R0 OHM +5% 250MI0W
R464	3093948016	1	PC	RCF 10K0 OHM +5% 250MI0W
R465	4043564016	1	PC	RCF 4K7 OHM +5% 250MI0W
R466	3093948016	1	PC	RCF 10K0 OHM +5% 250MI0W
R467	3093951016	1	PC	RCF 100K0 OHM +5% 250MI0W
R468	3093948016	1	PC	RCF 10K0 OHM +5% 250MI0W
R469	3093951016	1	PC	RCF 100K0 OHM +5% 250MI0W
R470	3093948016	1	PC	RCF 10K0 OHM +5% 250MI0W
R471	3093951016	1	PC	RCF 100K0 OHM +5% 250MI0W
R472	2046946016	1	PC	RCF 2K2 OHM +5% 250MI0W
R473	3093948016	1	PC	RCF 10K0 OHM +5% 250MI0W
R474	3093951016	1	PC	RCF 100K0 OHM +5% 250MI0W
R475	3093951016	1	PC	RCF 100K0 OHM +5% 250MI0W
<i>Miscellaneous</i>				
S441	556591600	1	PC	SWIPUSH POWER SWITCH 10.0A 250.0V 100MIOOHM 1T 2P
SK41	55127440NR	1	PC	RELAYPWR 12.0V 270.0OHM 10.0A
SK42	55231610NR	1	PC	RELAYPWR 12.0V 270.0OHM 16.0A
SK43	55231610NR	1	PC	RELAYPWR 12.0V 270.0OHM 16.0A
T541	55648780NR	1	PC	TF-LAM ST/BY-TRANSFORMER 120V
N412	556867600	1	PC	WIRECONASY UNIQUE 3P 600MM UL1007 RIBBON 24 1
N453	555976500	1	PC	WIRECONASY DL 2.0MM 3P 530MM UL2547 26 1
N462	556867300	1	PC	WIRECONASY UNIQUE 2P 250MM UL1007 PVC DISCRETE 16 1
N466	556867100	1	PC	WIRECONASY UNIQUE 2P 200MM UL1007 PVC DISCRETE 16 1
N606	557244700	1	PC	WIRECONASY UNIQUE 5P 750MM UL1007 PVC DISCRETE 26 1
N707	557262100	1	PC	WIRECONASY UNIQUE 3P 300MM UL1007 RIBBON 22 1
N708	557262200	1	PC	WIRECONASY UNIQUE 4P 300MM UL1007 RIBBON 22 1
F451	20870650NR	1	PC	FUSE SLO-BLO 3.0 A 250.0 V
F452	55724420NR	1	PC	FUSE SLO-BLO 15.0 A 250.0 V
F453	55521310NR	1	PC	FUSE SLO-BLO 500MIO A 250.0 V
F454	55170760NR	1	PC	FUSE SLO-BLO 1.5 A 125.0 V
F455	55170760NR	1	PC	FUSE SLO-BLO 1.5 A 125.0 V
	55170330CM	2	PC	TERMFUSEHLDR FUSE-HOLDER J4210020001X FOR F451-455
	55170330CM	2	PC	TERMFUSEHLDR FUSE-HOLDER J4210020001X FOR F451-455
	55170330CM	2	PC	TERMFUSEHLDR FUSE-HOLDER J4210020001X FOR F451-455
	55170330CM	2	PC	TERMFUSEHLDR FUSE-HOLDER J4210020001X FOR F451-455
	55170330CM	2	PC	TERMFUSEHLDR FUSE-HOLDER J4210020001X FOR F451-455
NJ21	55125430NR	1	PC	D-LEM TORX178B RD RND CL
NJ22	55175950	1	PC	CON PHONO SCKT RCA 1P W/GND JE010003MN
NJ41	55222010	1	PC	CON MAINS INLET A/C INLET 7014-NGP
NJ42	55231540NR	1	PC	CONN-SPE A206D0054P AC OUTLET US NA 15.25MM 3 BK 0 A0
NJ48	55050690	1	PC	CONN-PHJAC 6.35 ST HORZ CKX3-6.35-04 BK 0 0
P212	55146570	1	PC	CONN 2.5MM 3 MA ST NAT 0 0
P213	55146580	1	PC	CONN 2.5MM 4 MA ST NAT 0 0
P401	55231370	1	PC	CON 11.88MM 6.0MM PITCH ACTUAL
P402	55090080	1	PC	CONN 2.0MM 3 MA ST NAT LW2002P03 0 0
P403	55231360	1	PC	CON 11.88MM 6.0MM PITCH ACTUAL
P404	55231370	1	PC	CON 11.88MM 6.0MM PITCH ACTUAL
P405	55231370	1	PC	CON 11.88MM 6.0MM PITCH ACTUAL
P406	55231370	1	PC	CON 11.88MM 6.0MM PITCH ACTUAL
P407	55231370	1	PC	CON 11.88MM 6.0MM PITCH ACTUAL
P408	55146630	1	PC	CONN 2.5MM 8 MA ST NAT 0 0
P409	55150370	1	PC	CONN 2.5MM 9 MA ST NAT 0 0
P454	55090070	1	PC	CONN 2.0MM 2 MA ST NAT LW2002P0200T 0 0
P463	55169140	1	PC	CON 3.96MM PITCH MOREX 35313-0210
P464	55171550	1	PC	CON 3.96MM PITCH MOREX 35313-0310
P465	55175430	1	PC	CON 3.96MM PITCH MOREX 35313-0410
P467	55169140	1	PC	CON 3.96MM PITCH MOREX 35313-0210
	55127070	2	PC	SCREW-ST 3MM 10MM JIS B 1122 J5636140010X 19 0 0
	55577410	1	PC	AC PUN BRACKET H/SINK BRIDGE --

Ref Designator	Part Number	Qty		Description
POWER SUPPLY				
	55127070	4	PC	SCREW-ST 3MM 10MM JIS B 1122 J5636140010X 19 0 0
	55182550	1	PC	AC PUN SHIELD DIGITAL ET
BE66	5512669050	1	PC	FBEAD SURFACE MT 2500OHM FCM2012H-252T02
BE67	5512669050	1	PC	FBEAD SURFACE MT 2500OHM FCM2012H-252T02
G401	55135980NR	1	PC	TERMLUG GND
G402	55135980NR	1	PC	TERMLUG GND
HS51	55304050	1	PC	AC HEATSINK BRIDGE 34.4*28.5*64H -- ME

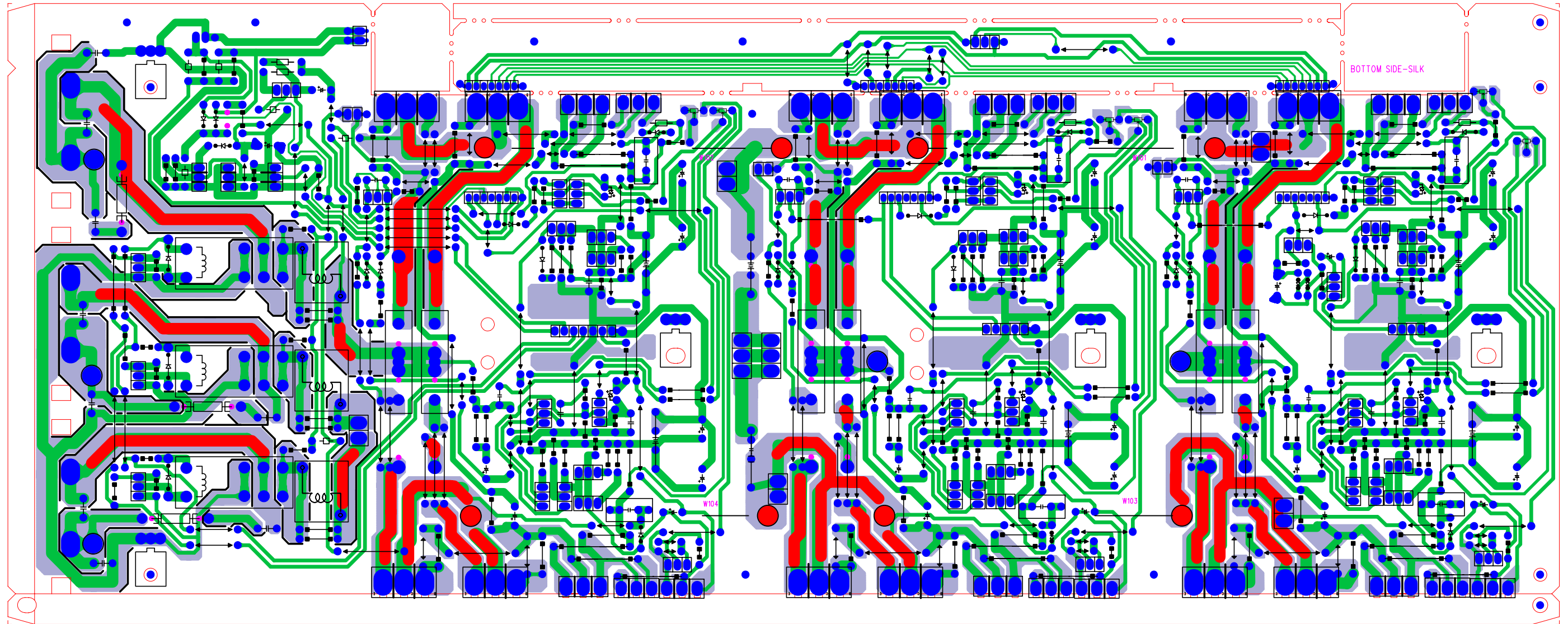

03.AVR7200-3CHAMP-M01-0 - Wed Mar 19 11:06:23 2003

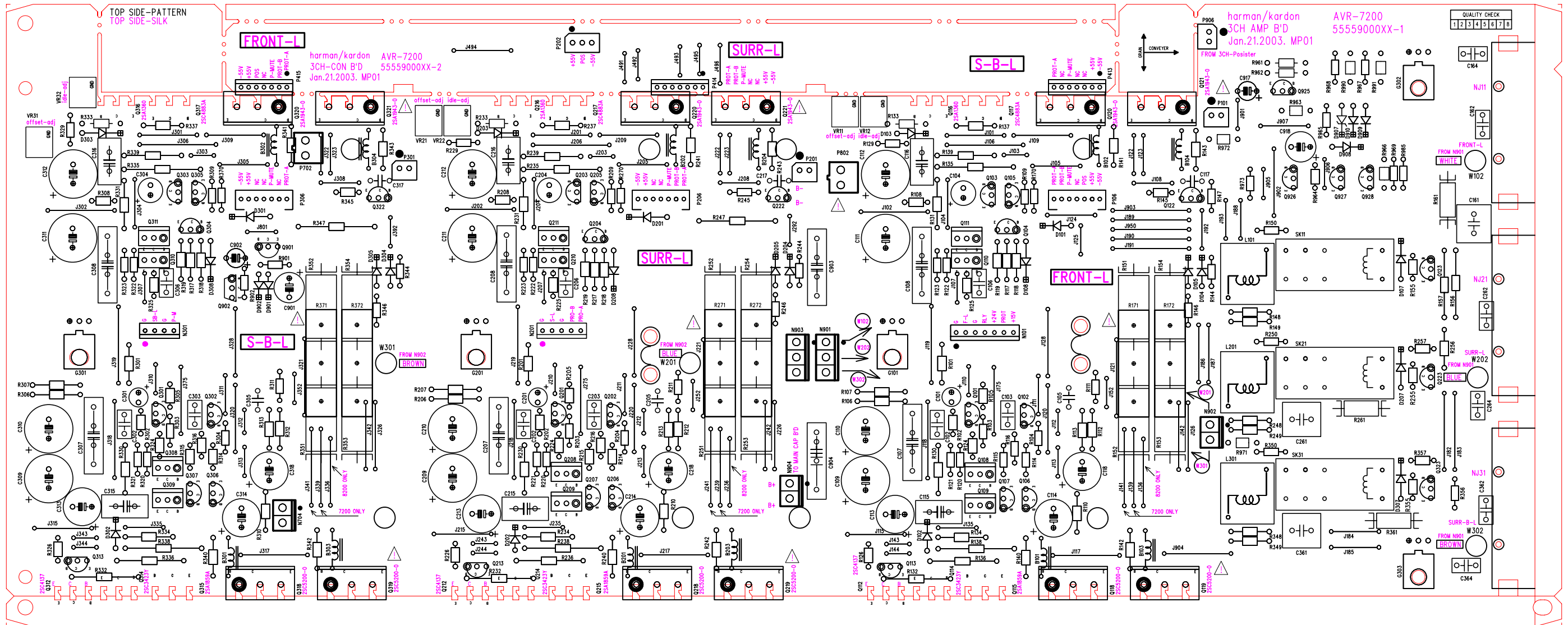

03.AVR7200-3CHAMP-M01-0 - Wed Mar 19 11:11:30 2003

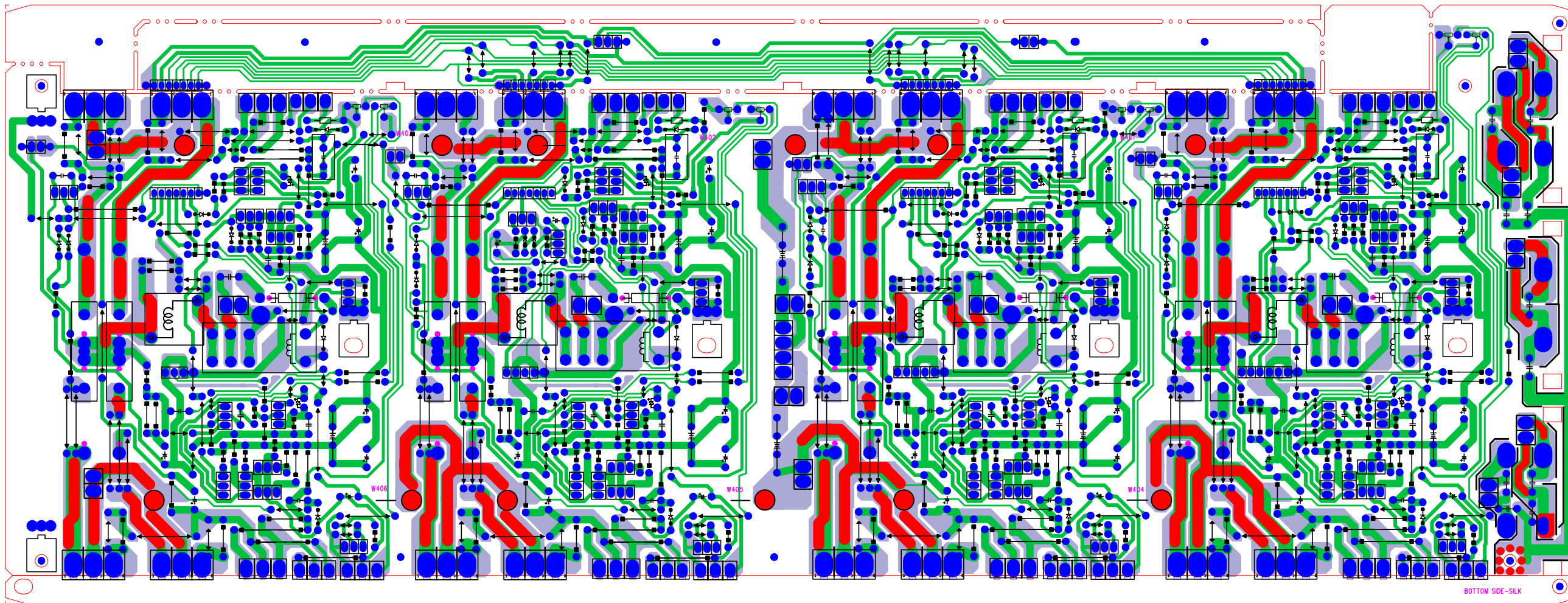

BOTTOM SIDE-SILK

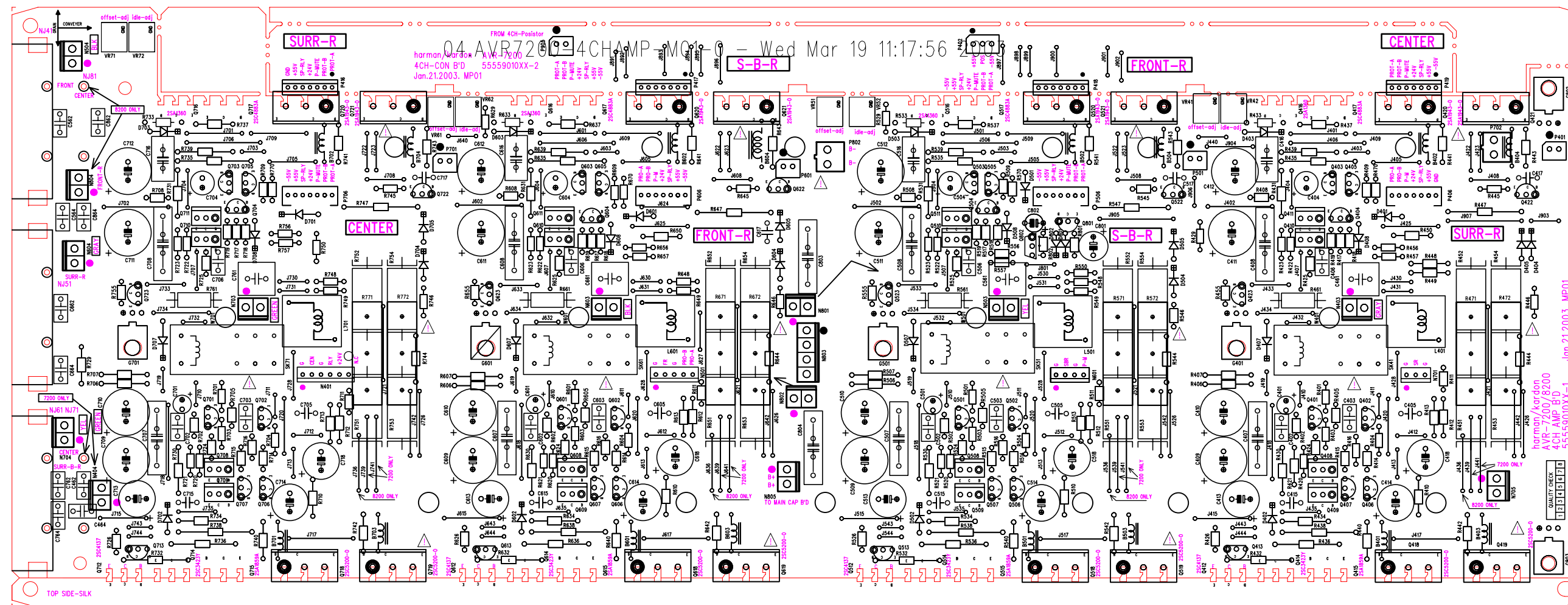

TOP SIDE-SILK

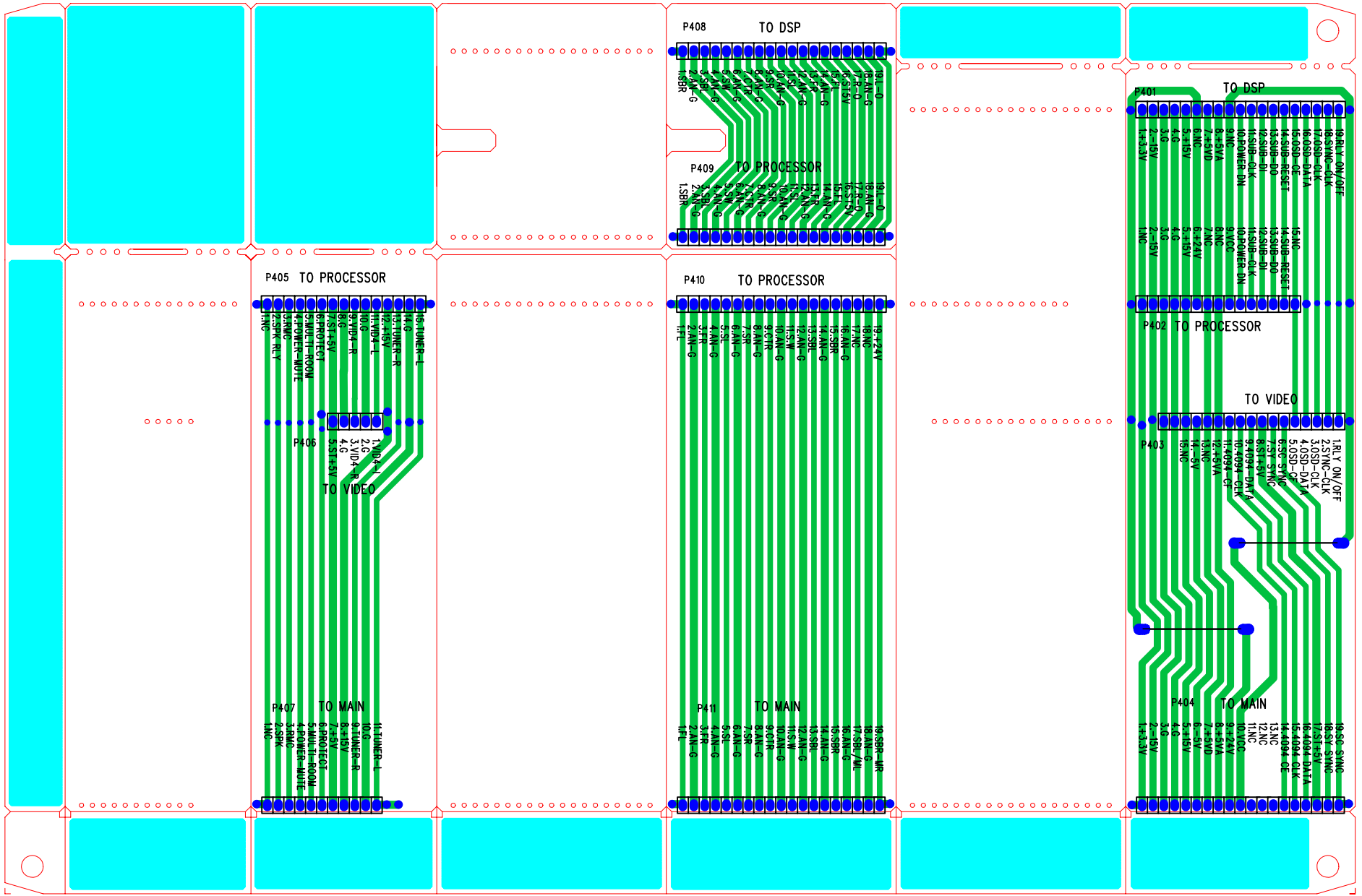

07.AVR7200 CONNECTOR M0 - Wed Mar 19 11:25:05 2003

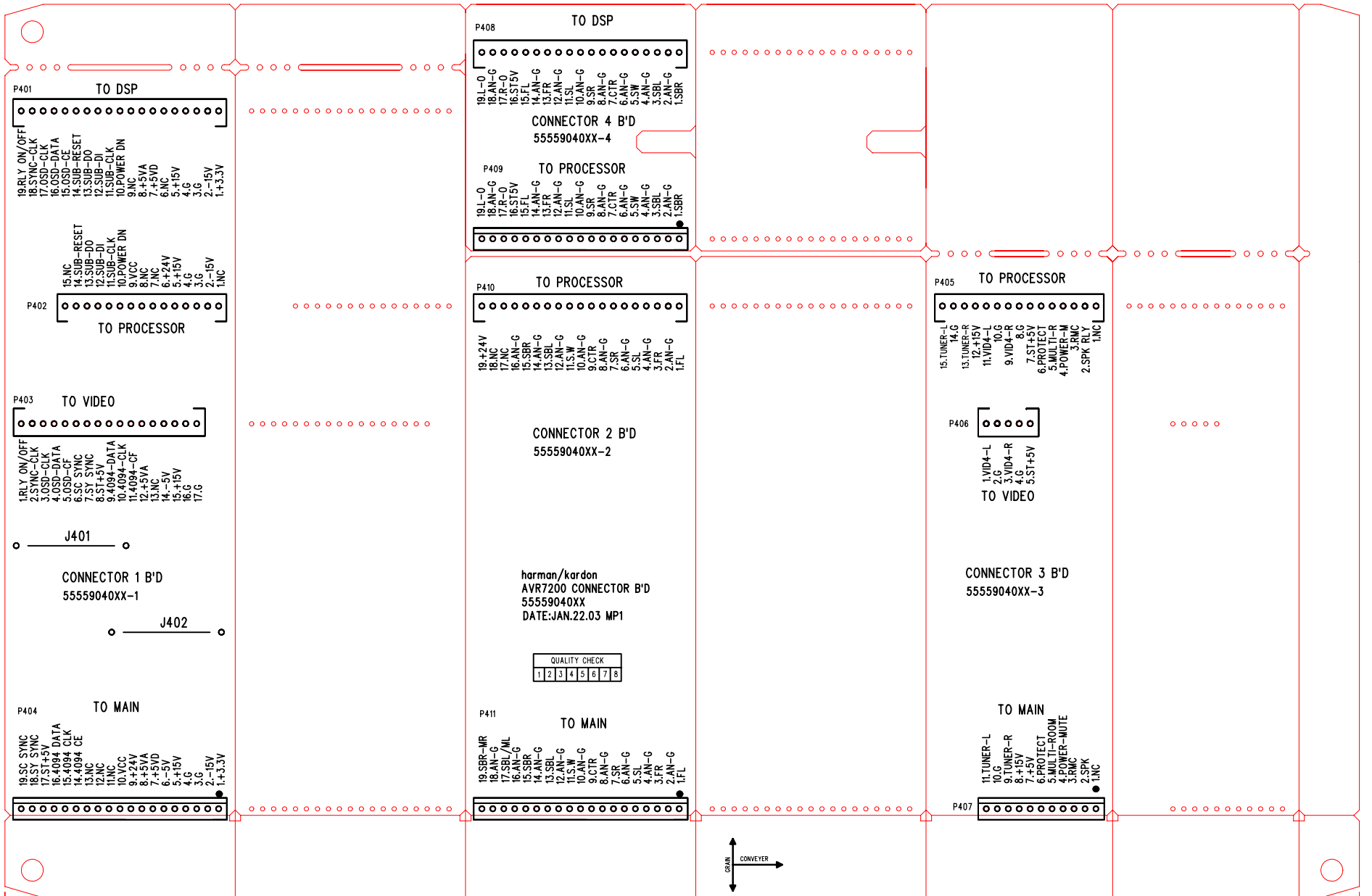

07.AVR7200 CONNECTOR M0 - Wed Mar 19 11:26:27 2003

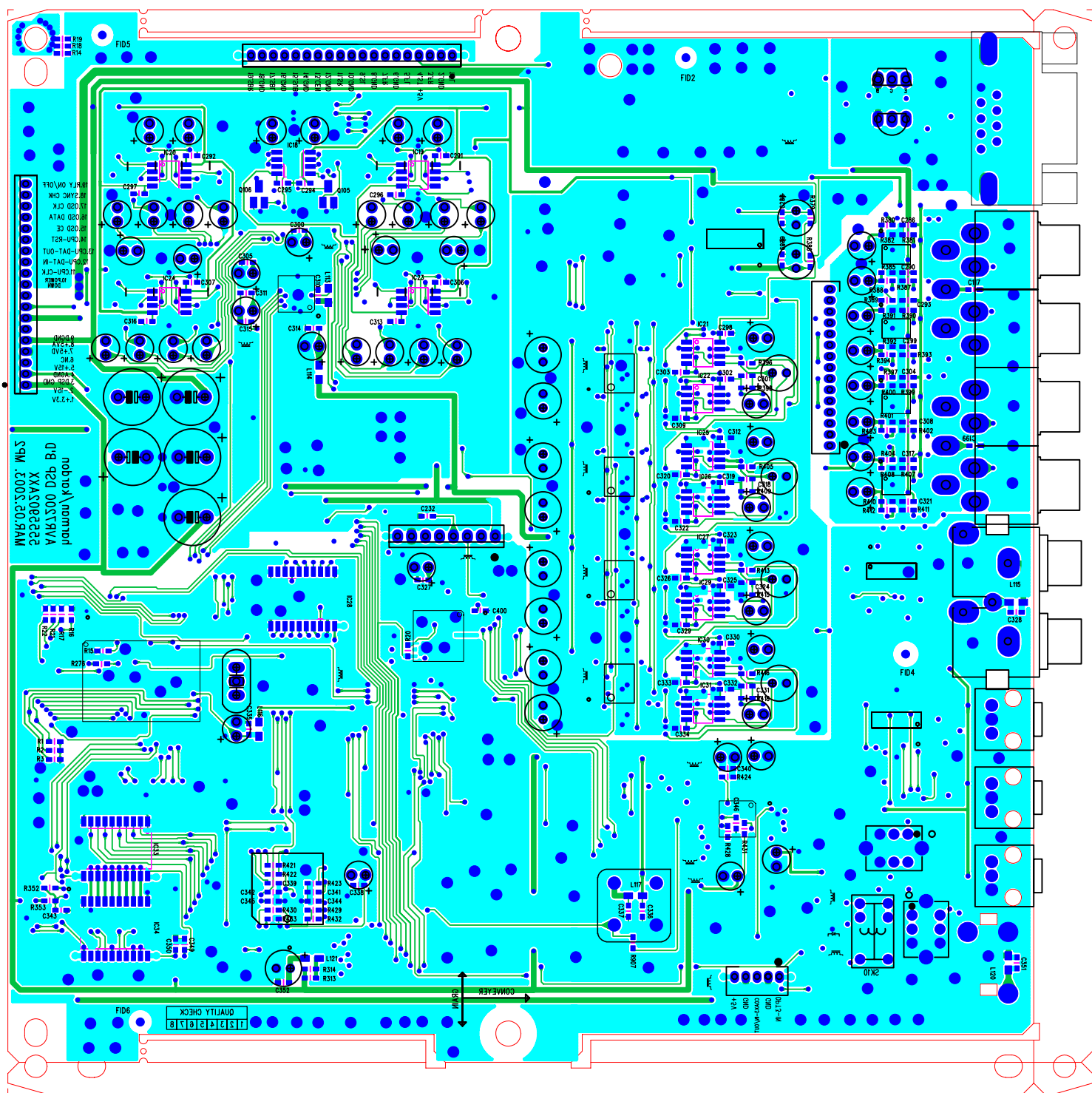

AVR7200 DSP M02_0305.pc - Wed Mar 19 09:13:29 2003

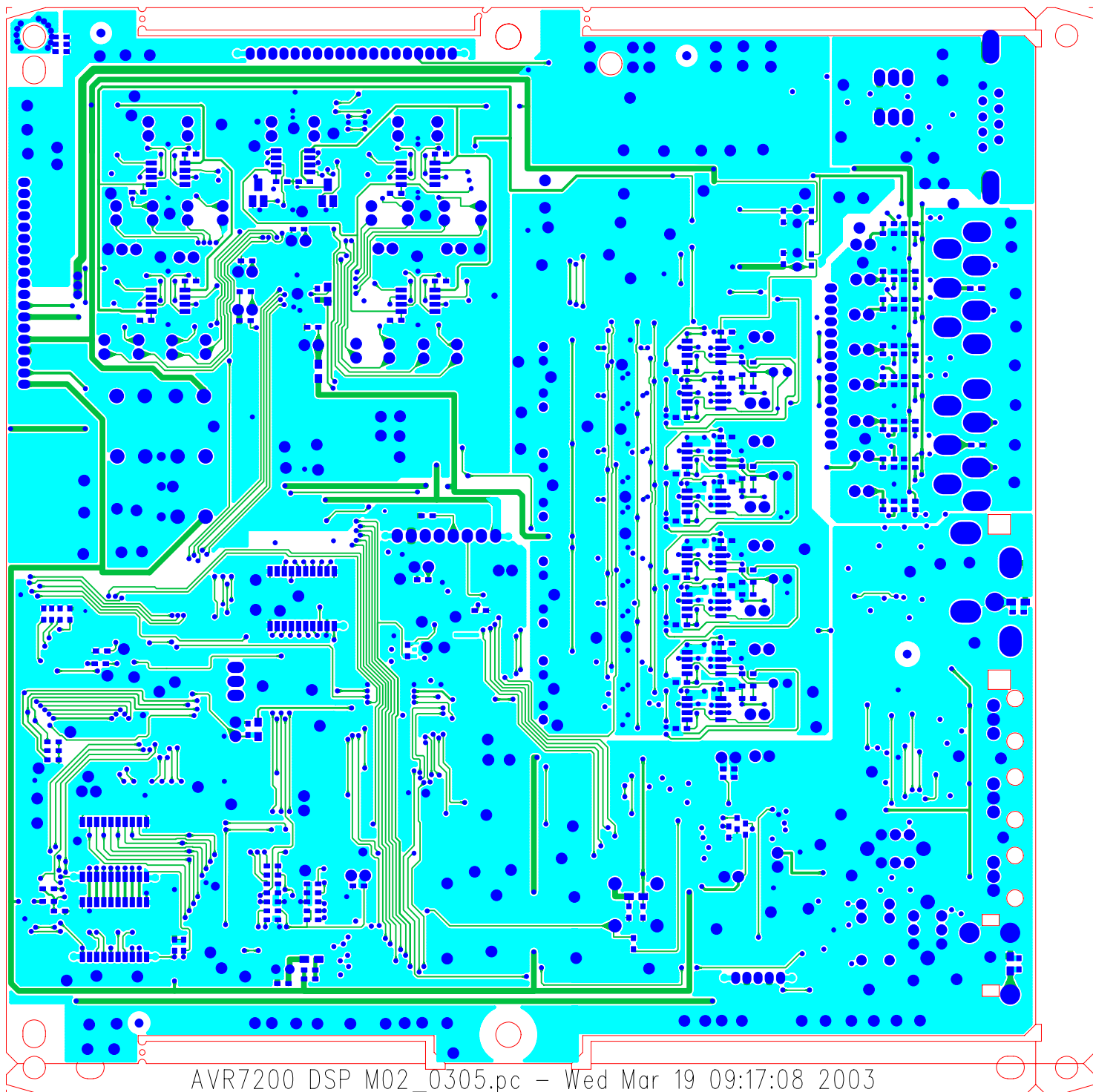

AVR7200 DSP M02_0305.pc - Wed Mar 19 09:17:08 2003

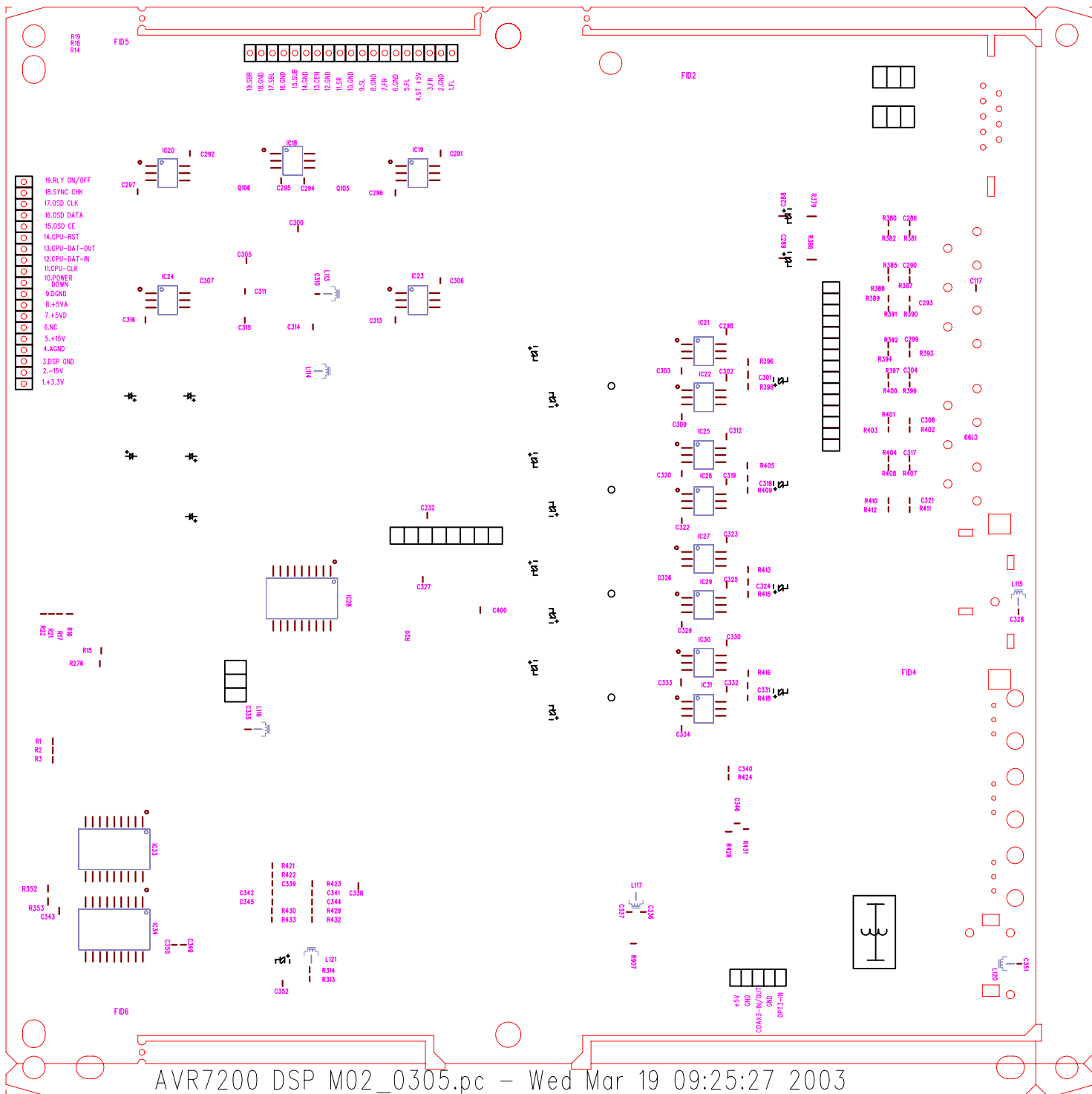

AVR7200 DSP M02_0305.pc - Wed Mar 19 09:25:27 2003

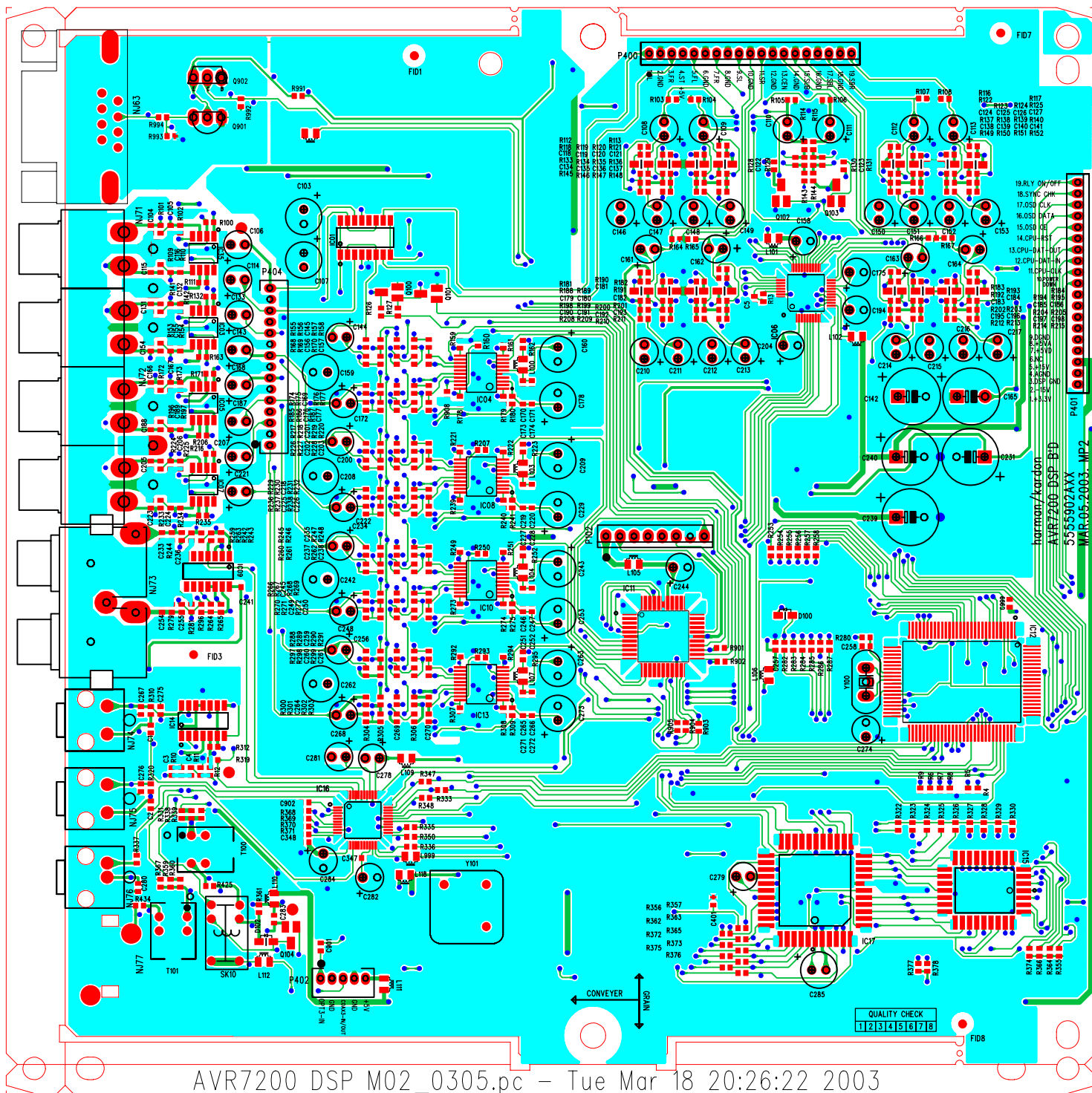

AVR7200 DSP M02_0305.pc - Tue Mar 18 20:26:22 2003

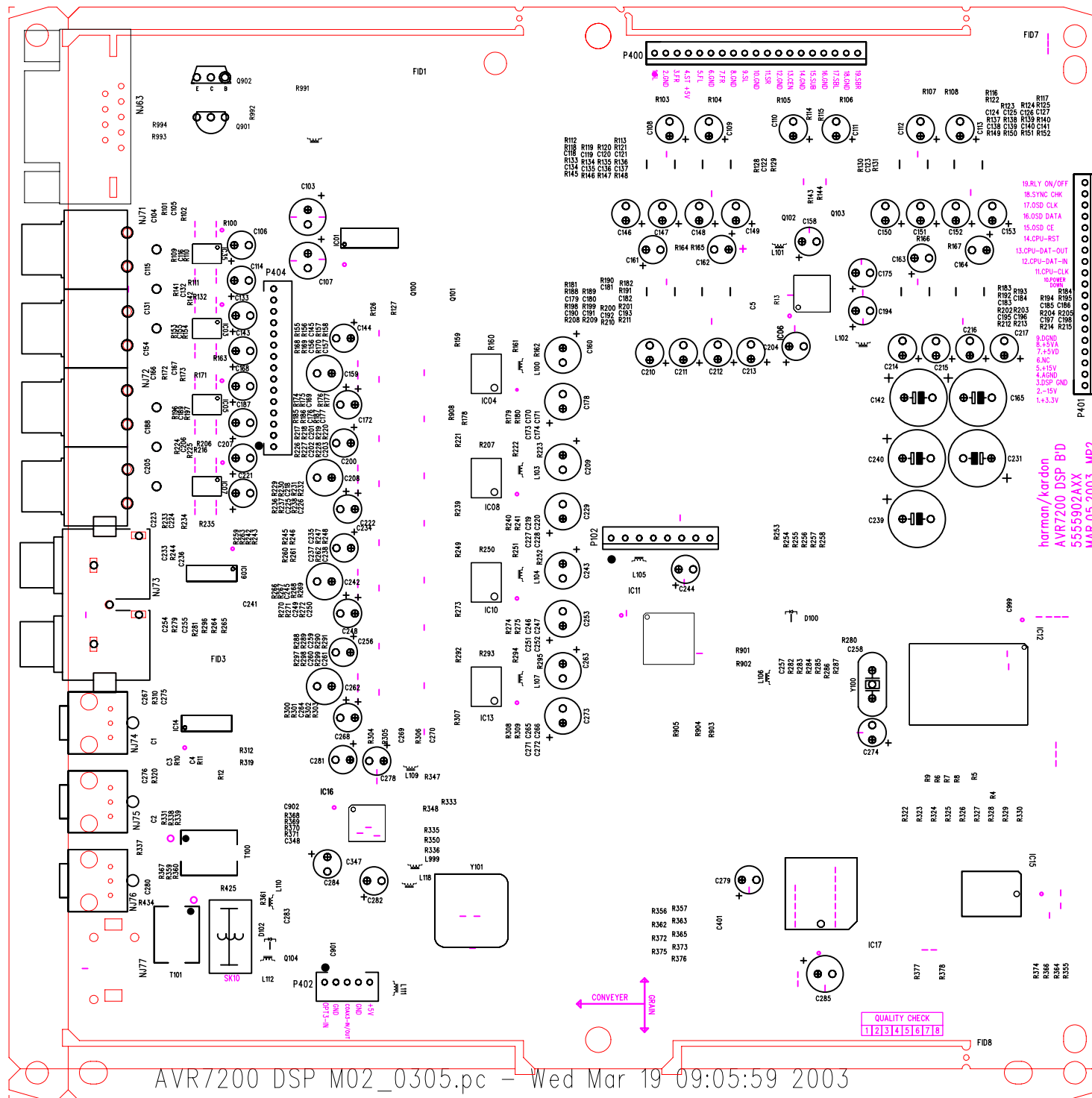
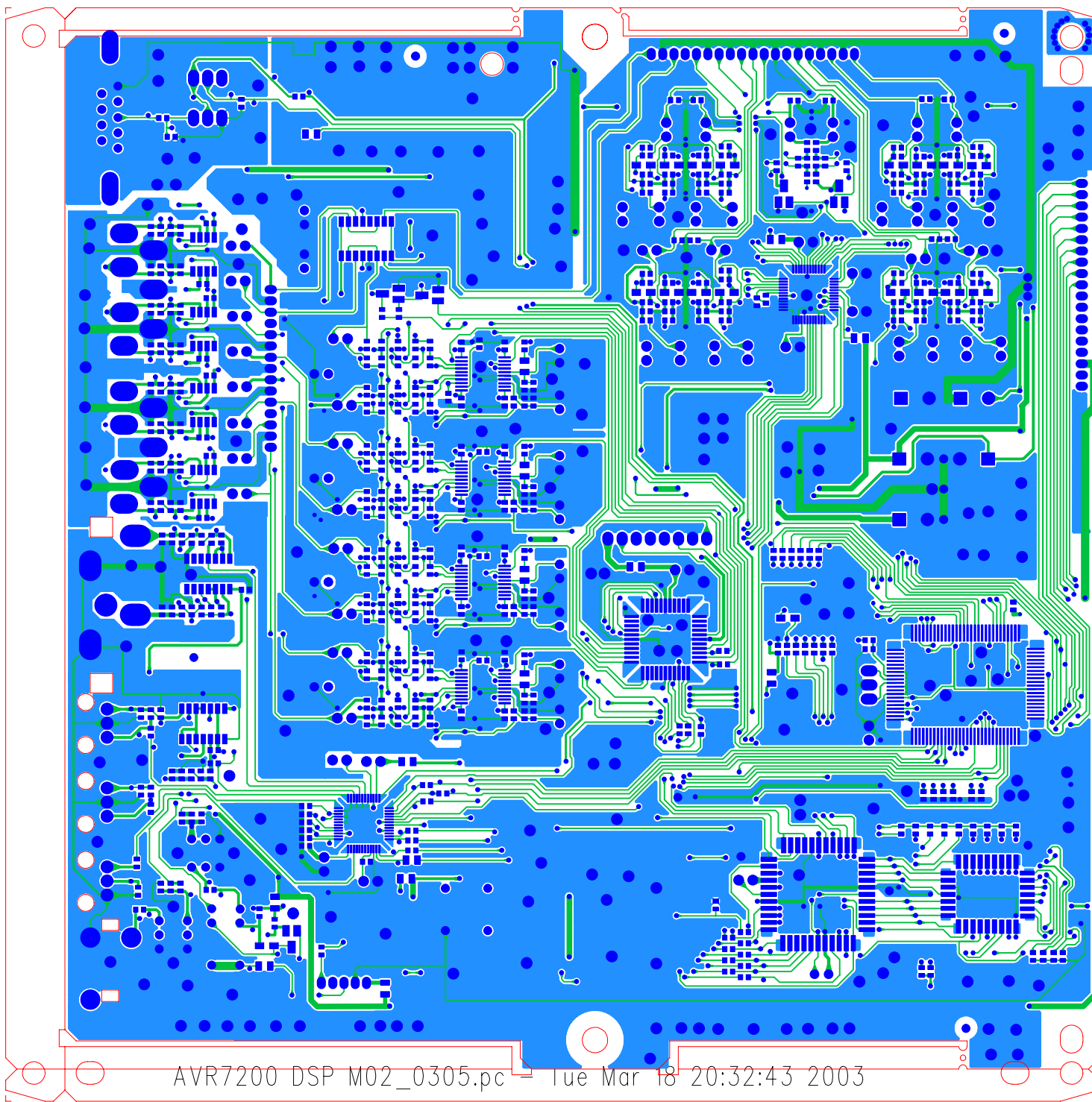

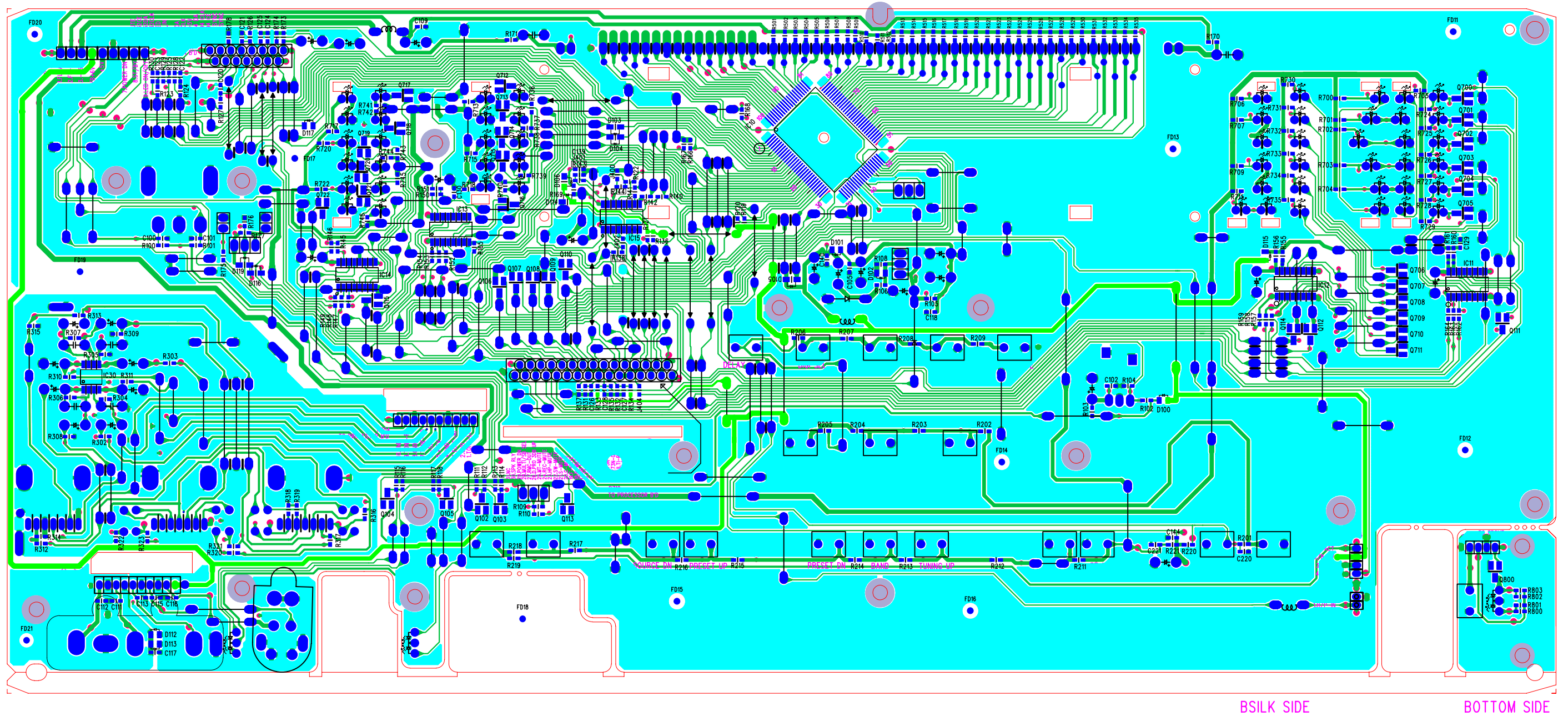

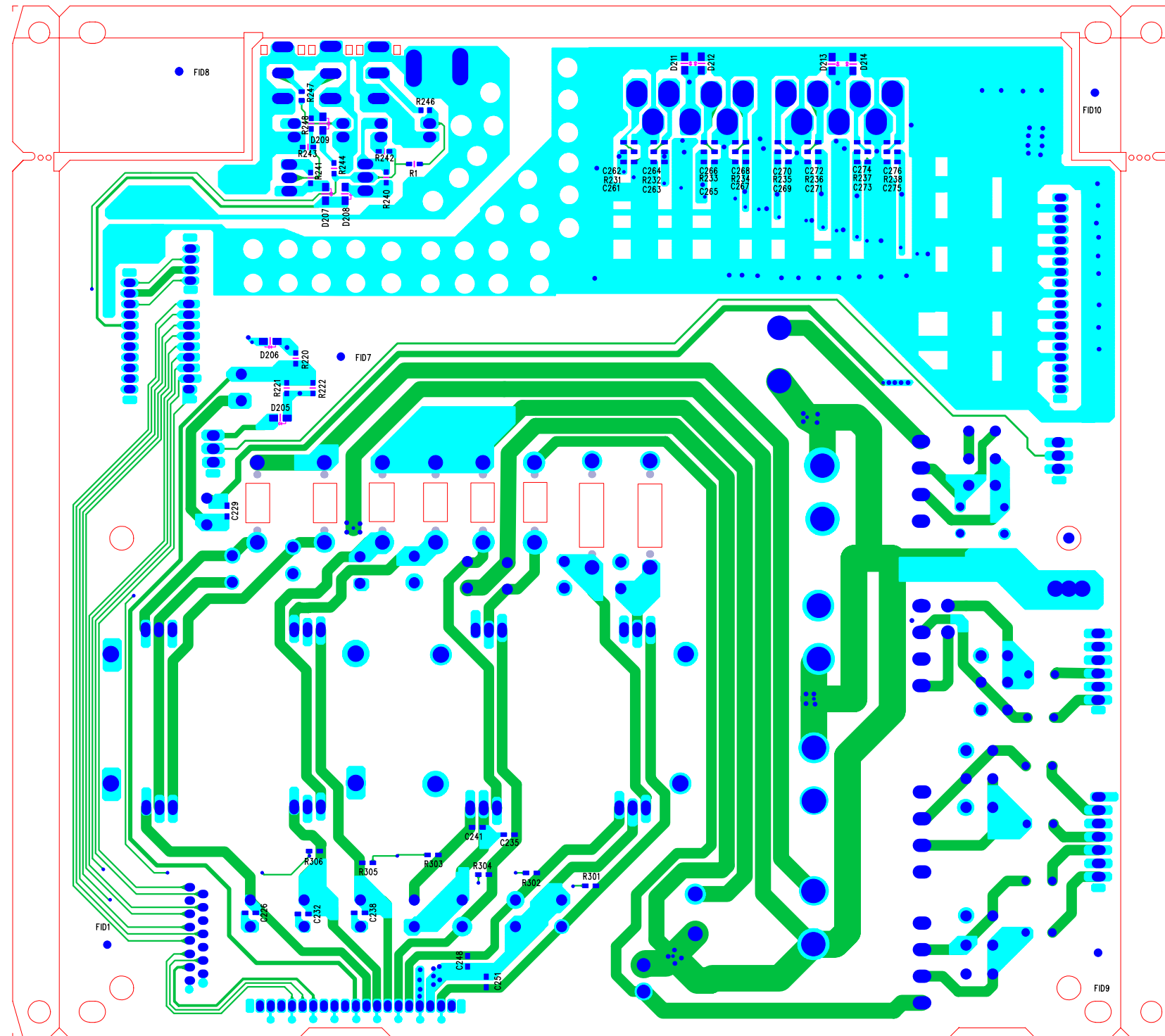

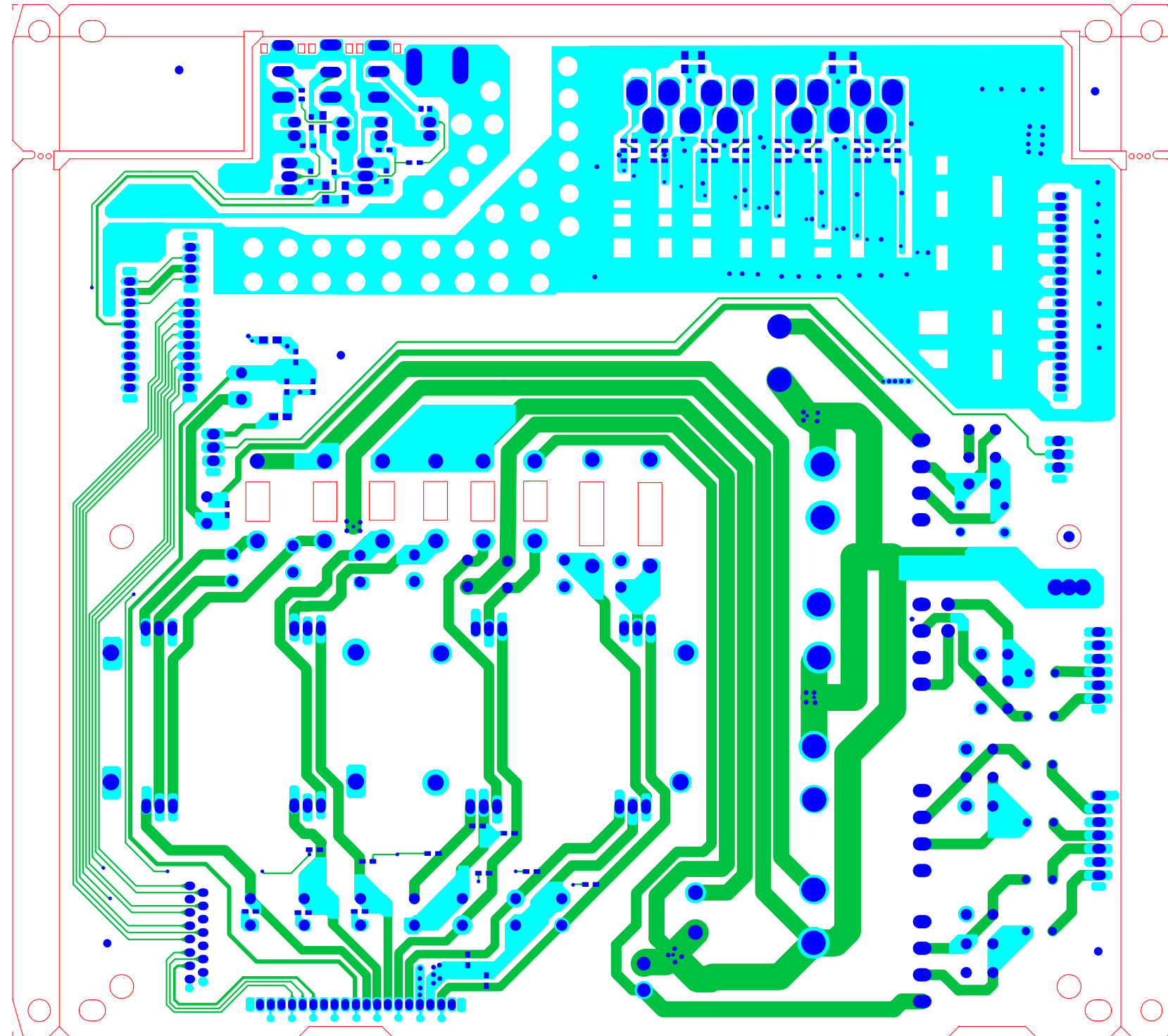

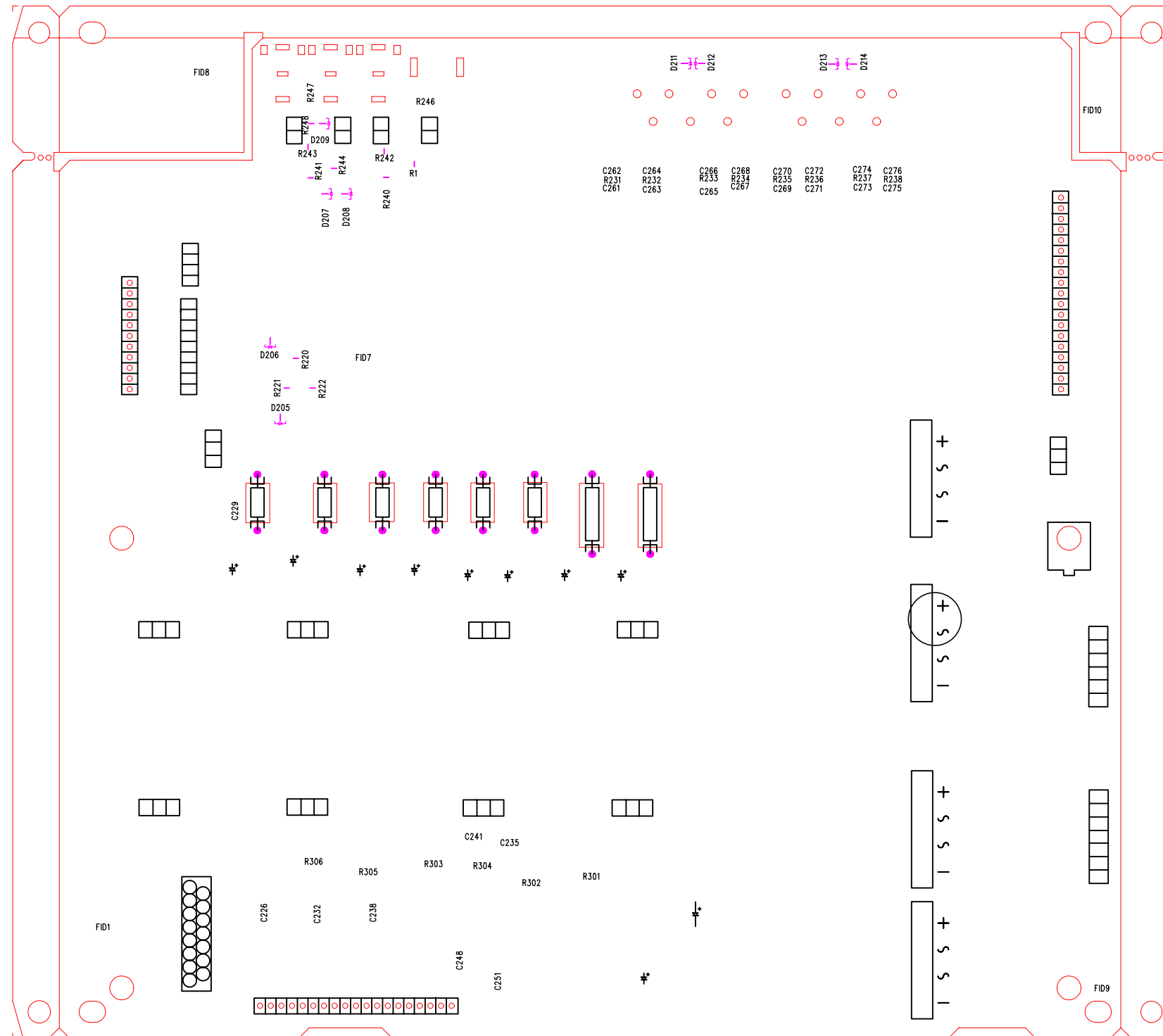

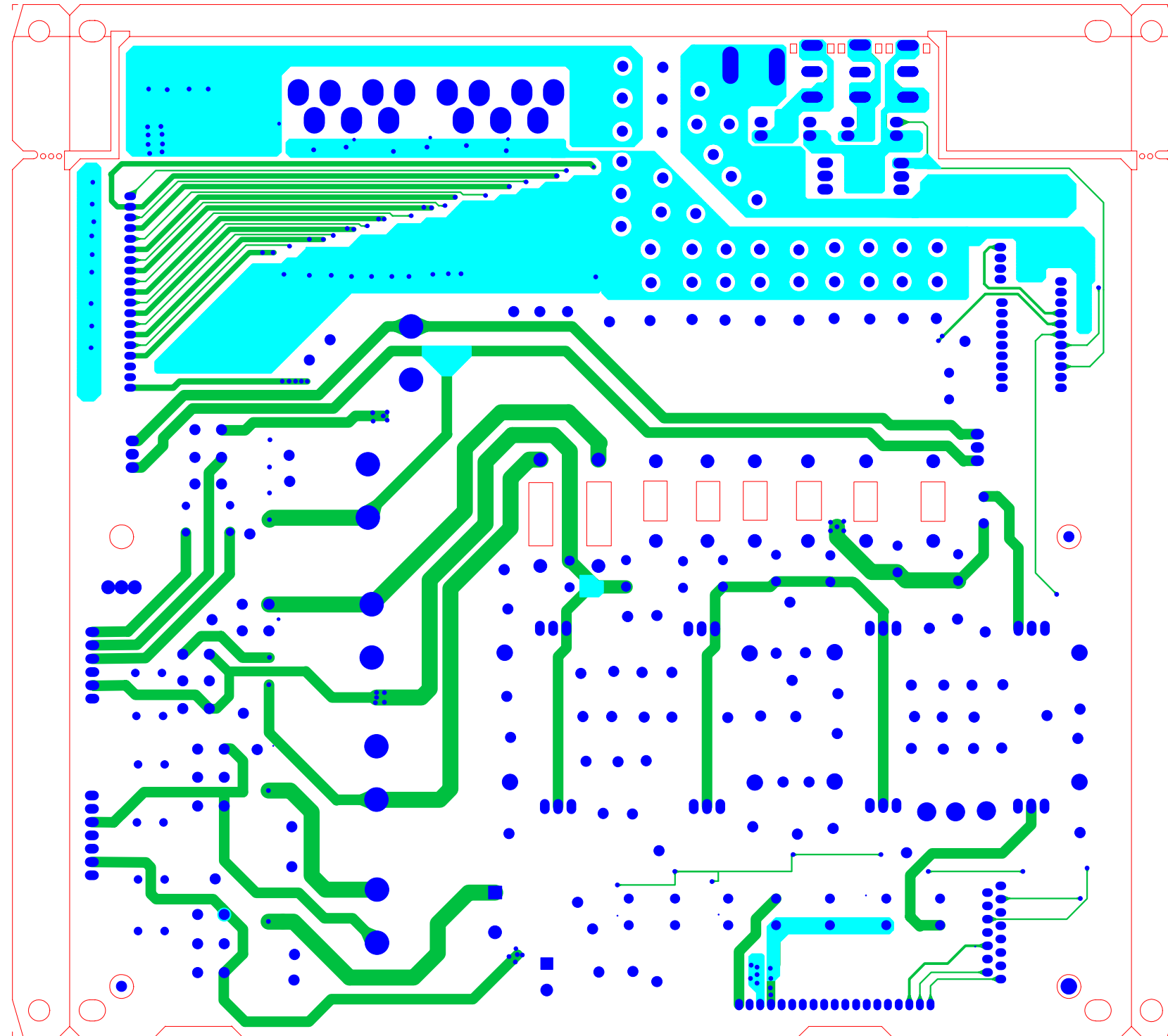

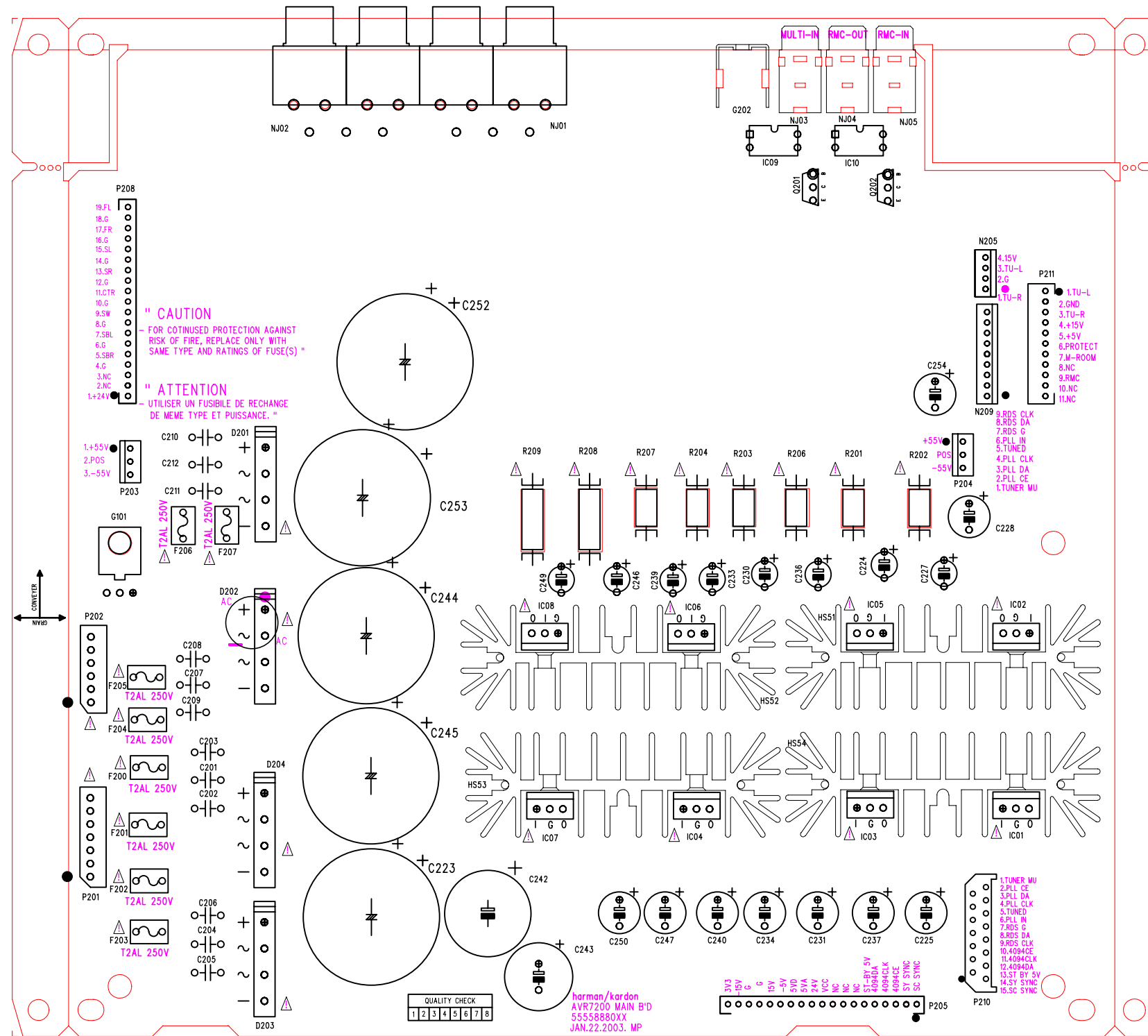

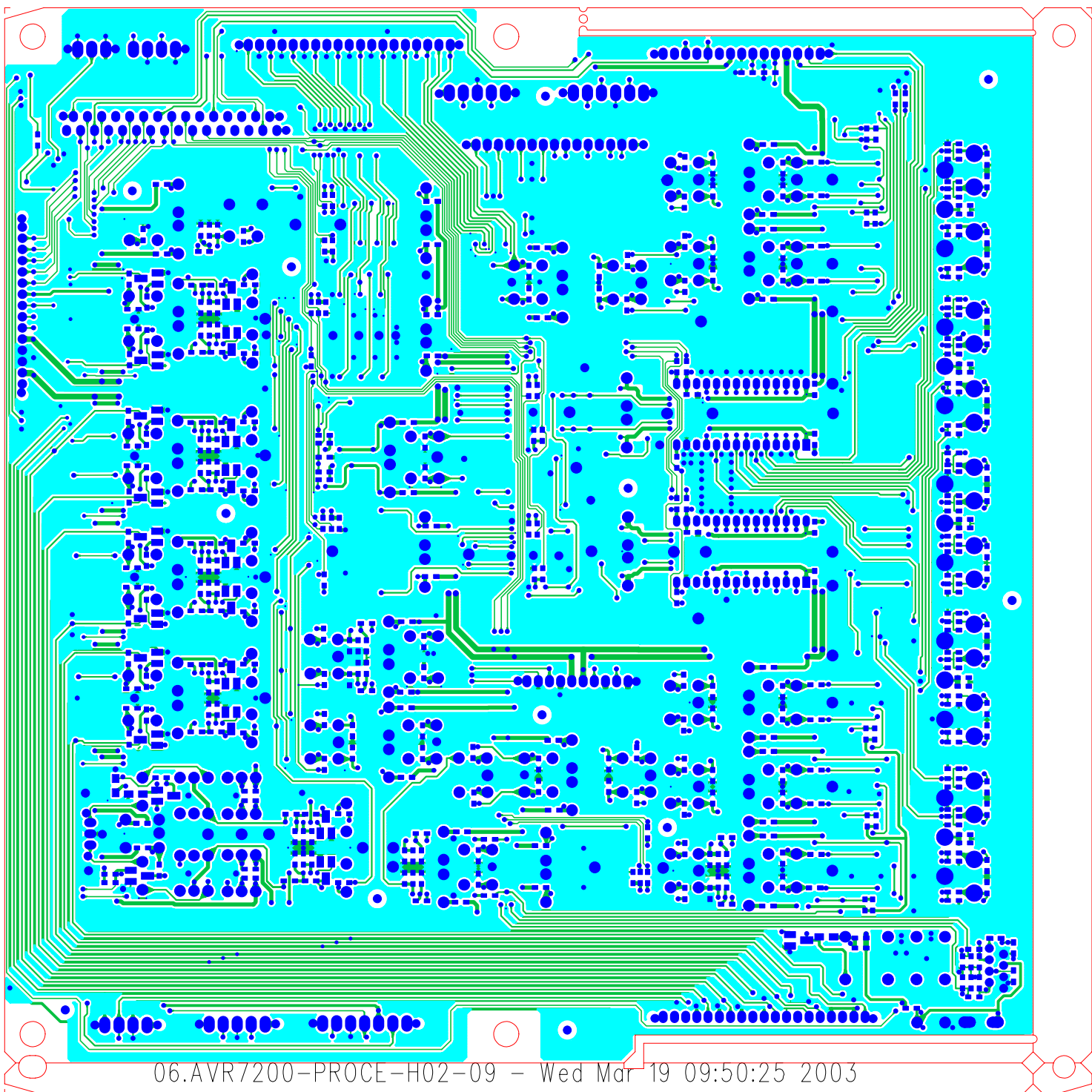
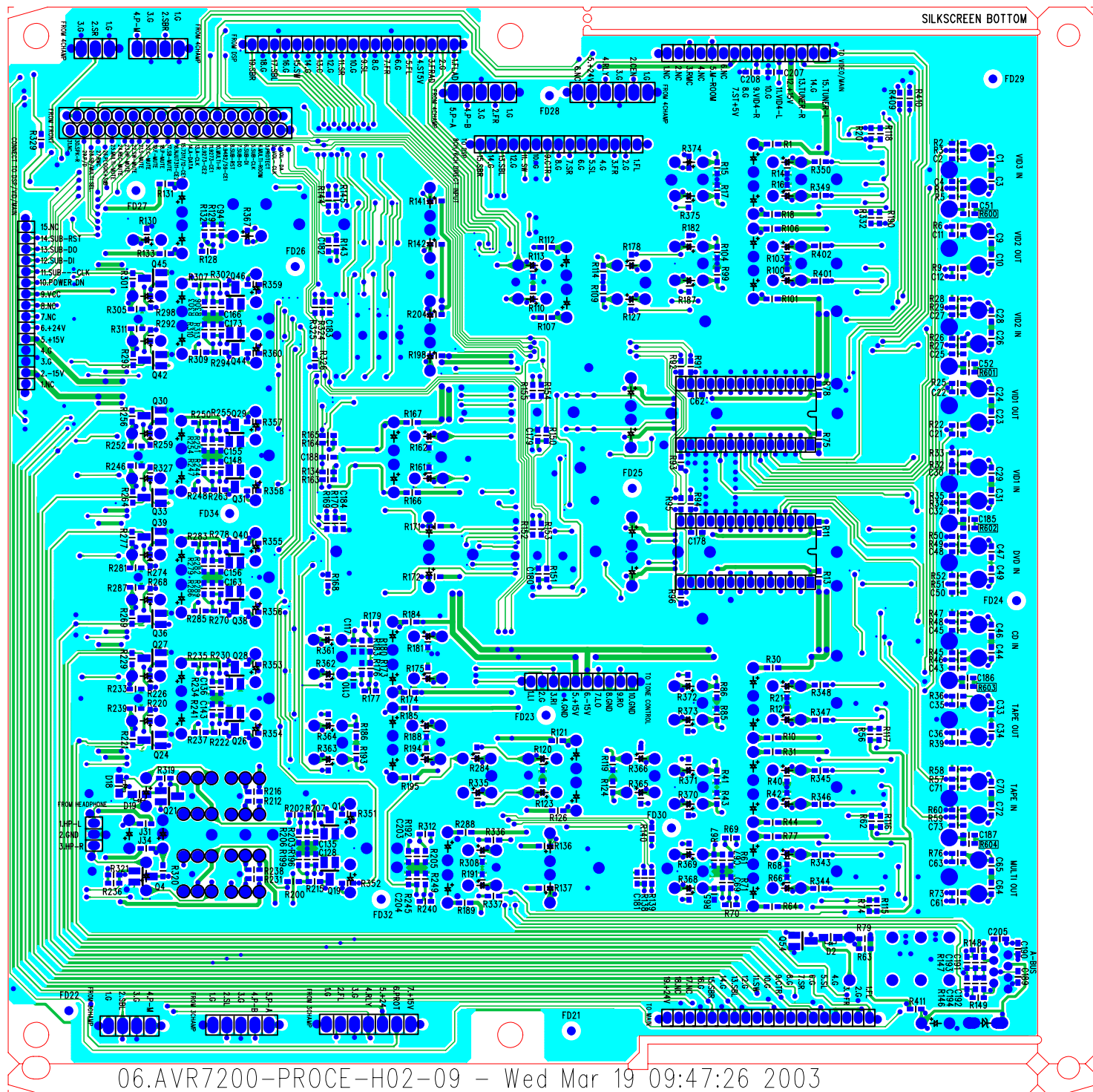

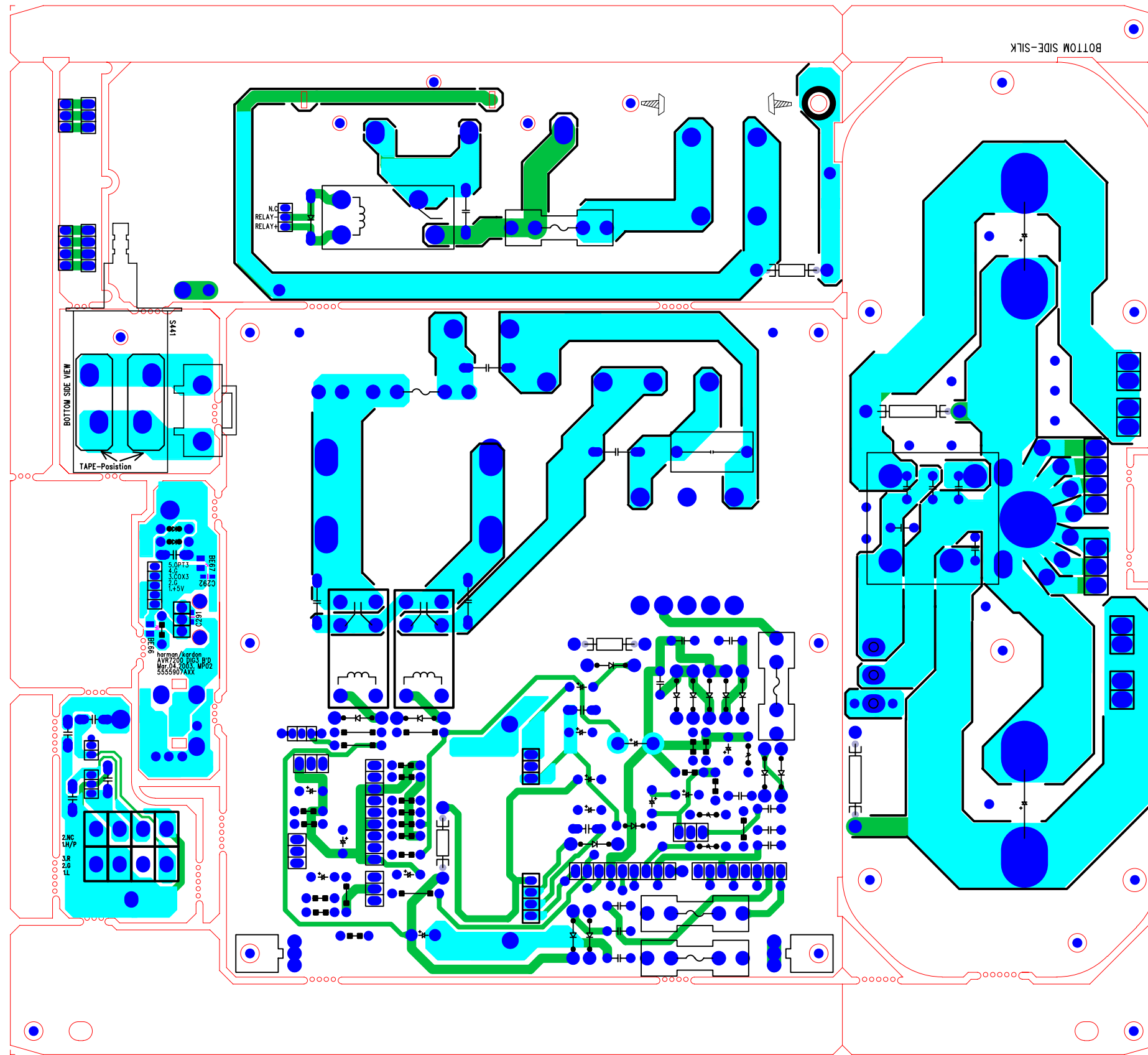

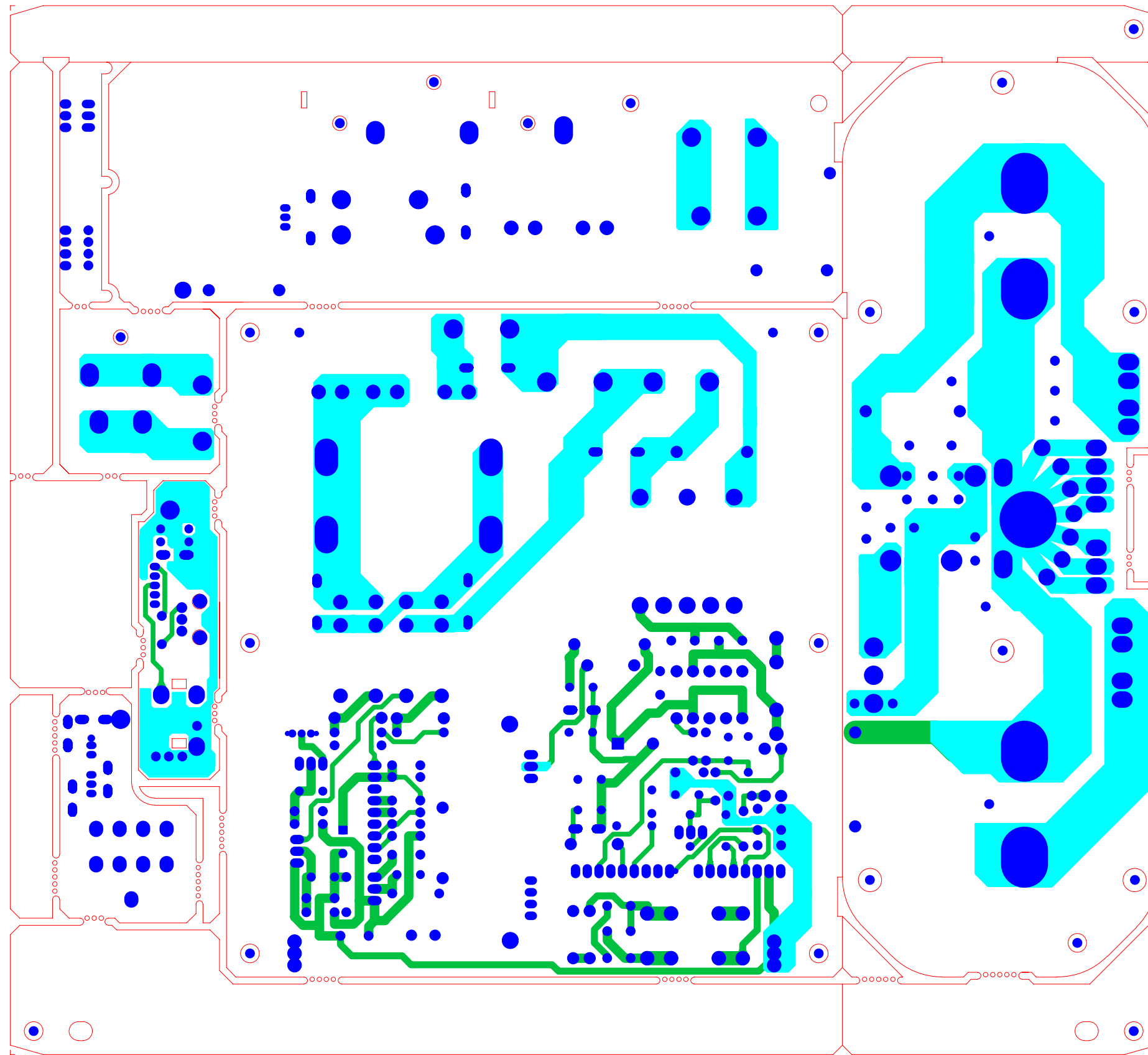

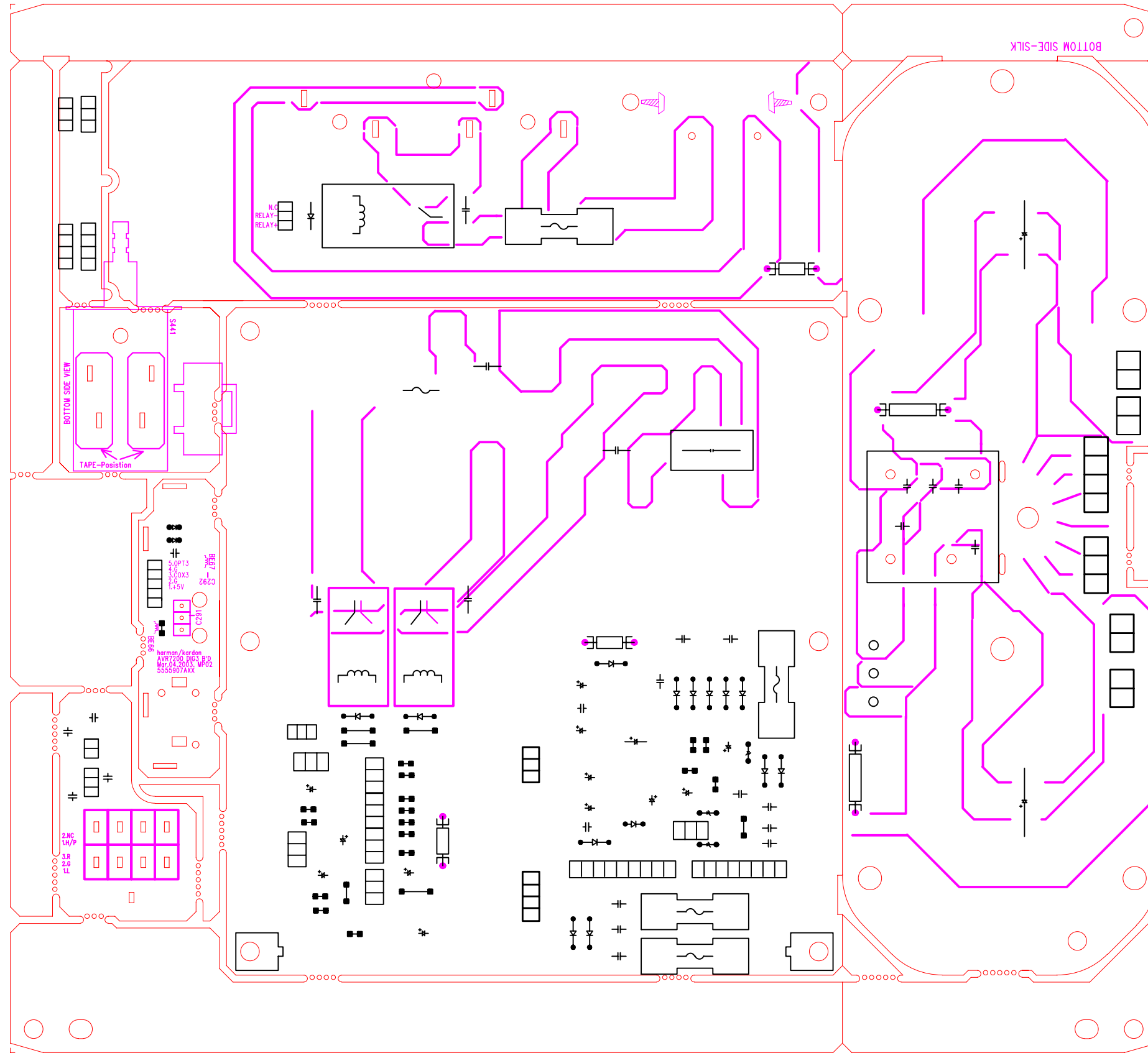

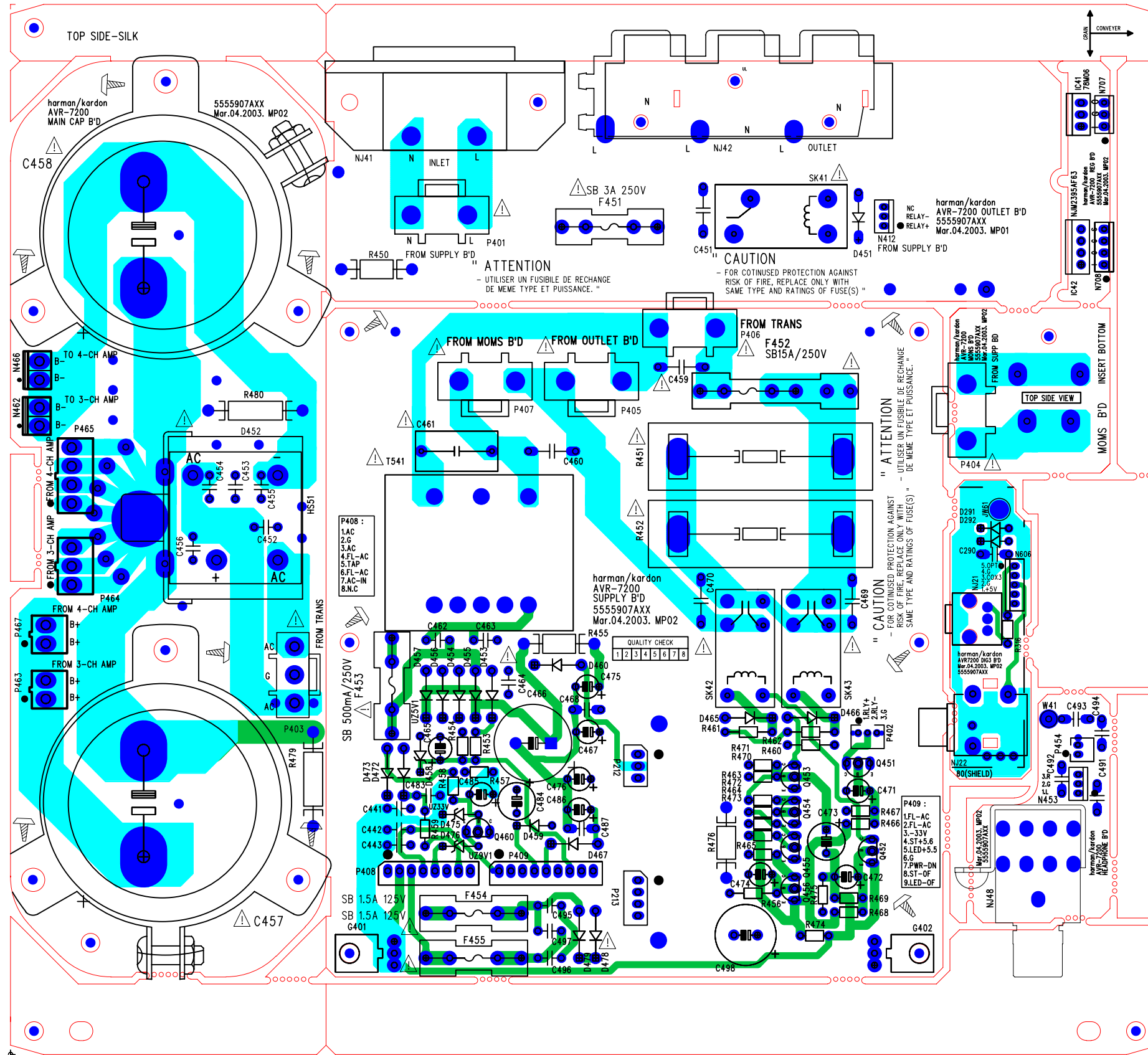

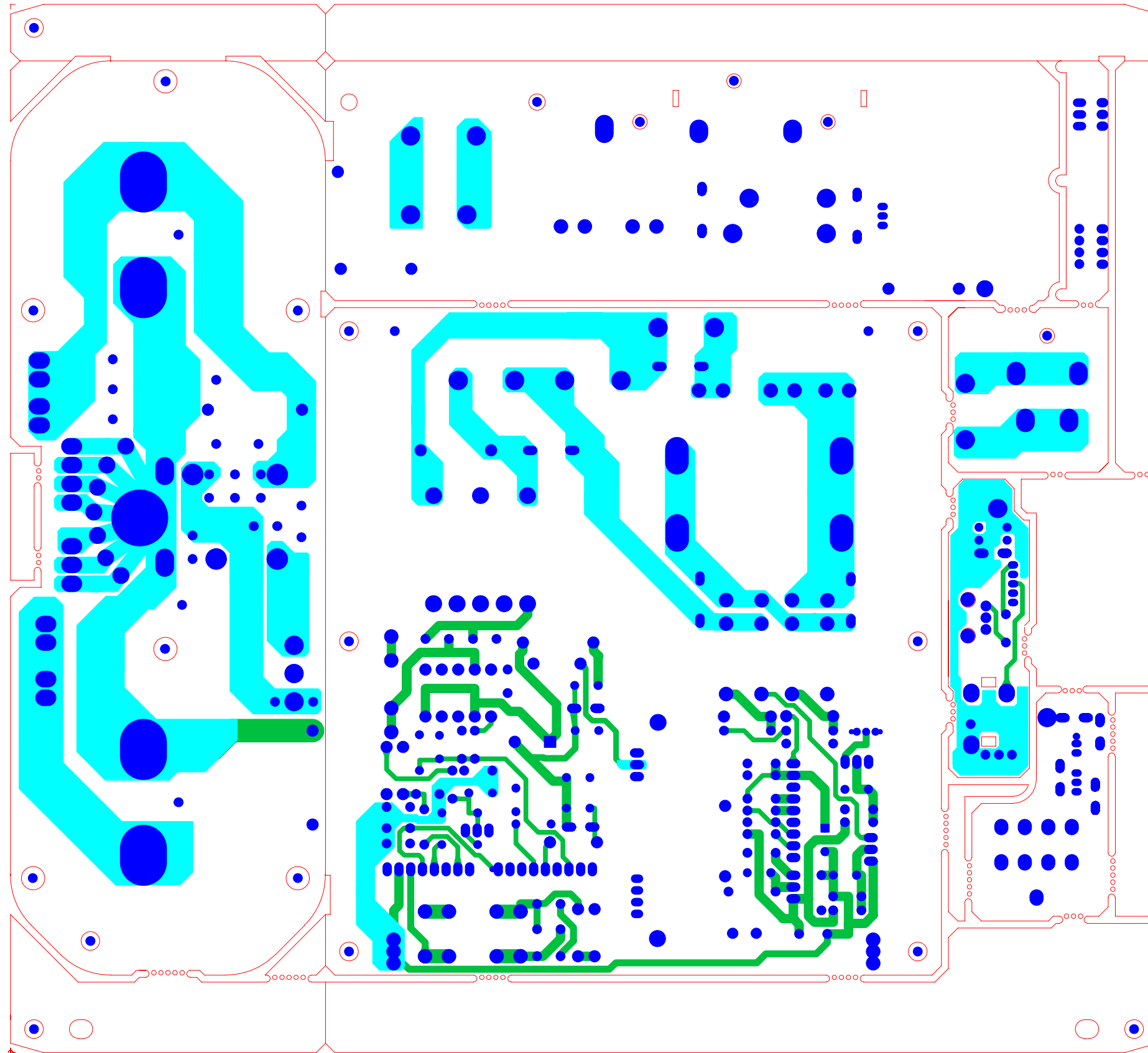

CMOS 8-Bit Single Chip Microcomputer IC

CXP82860

SONY

CXP82832/82840/82852/82860

Pin Assignment (Top View)

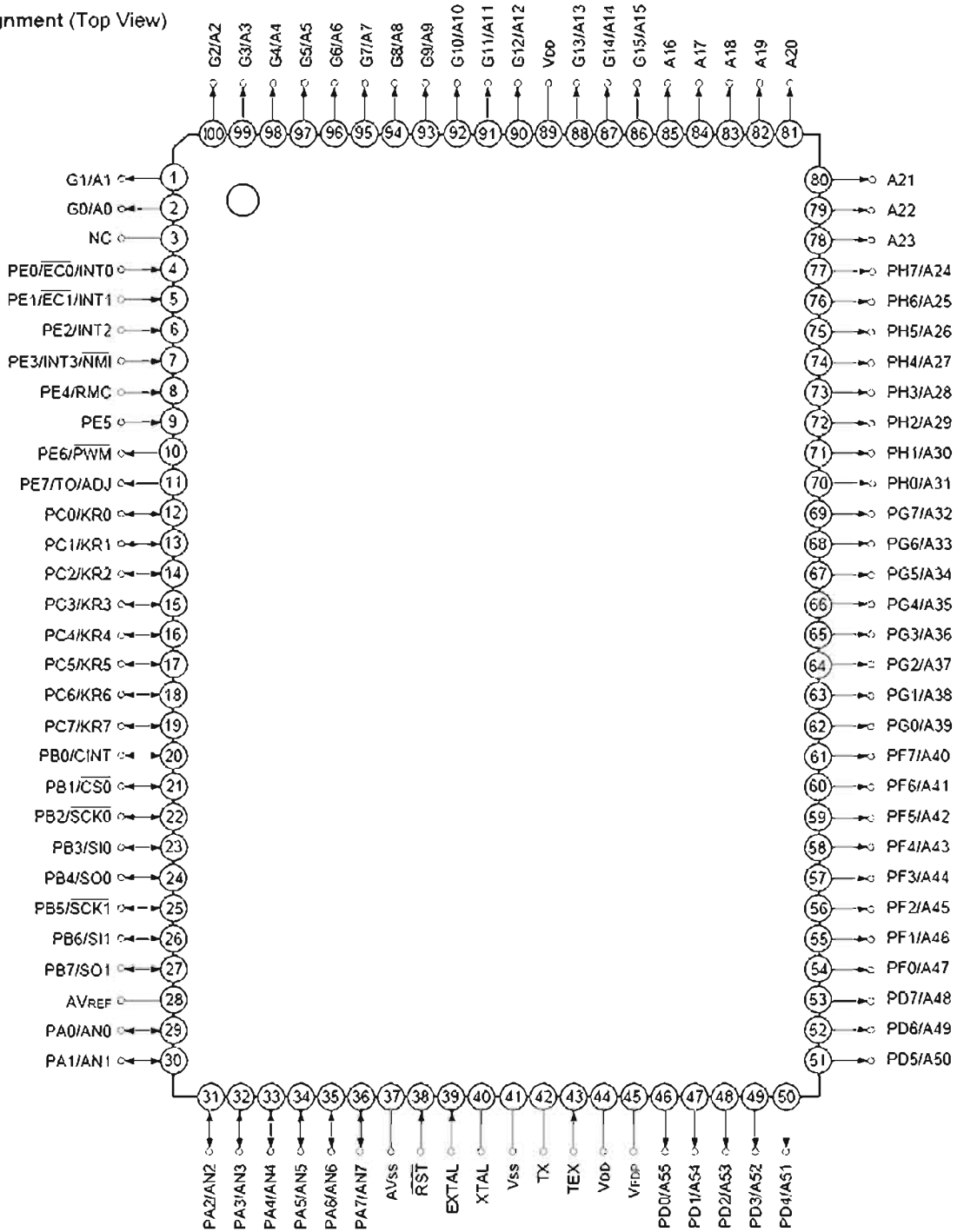

- Note)** 1. NC (Pin 3) must be connected to VDD.
2. VDD (Pins 44 and 89) must be connected to VDD.

Pin code	I/O	Functions		
PA0/AN0 to PA7/AN7	I/O/ Analog input	(Port A) 8-bit I/O port. I/O can be set in a unit of single bits. Incorporation of the pull-up resistor can be set through the software in a unit of 4 bits. (8pins)	Analog inputs to A/D converter. (8 pins)	
PB0/CINT	I/O/Input	(Port B) 8-bit I/O port. I/O can be set in a unit of single bits. Incorporation of the pull-up resistor can be set through the software in a unit of 4 bits. (8 pins)	Capture input to 16-bit timer/counter.	
PB1/ $\overline{CS0}$	I/O/Input		Chip select input for serial interface (CH0).	
PB2/ $\overline{SCK0}$	I/O/I/O		Serial clock I/O (CH0).	
PB3/SI0	I/O/Input		Serial data input (CH0).	
PB4/SO0	I/O/Output		Serial data output (CH0).	
PB5/ $\overline{SCK1}$	I/O/I/O		Serial clock I/O (CH1).	
PB6/SI1	I/O/Input		Serial data input (CH1).	
PB7/SO1	I/O/Output		Serial data output (CH1).	
PC0/KR0 to PC7/KR7	I/O/Input	(Port C) 8-bit I/O port. I/O can be set in a unit of single bits. Can drive 12mA sync current. Incorporation of the pull-up resistor can be set through the software in a unit of 4 bits. (8 pins)	Serves as key return inputs when operating key scan with fluorescent display panel (FDP) segment signal. (8 pins)	
PD0/A55 to PD7/A48	Output/Output	(Port D) 8-bit output port. (8 pins)	FDP segment signal (anode connection) outputs.	
PE0/INT0/ $\overline{EC0}$	Input/Input/Input	(Port E) 8-bit port. Lower 6 bits are for inputs; upper 2 bits are for outputs. (8 pins)	Inputs for external interruption request. (4 pins)	External event inputs for timer/counter. (2 pins)
PE1/INT1/ $\overline{EC1}$	Input/Input/Input			Non-maskable interruption request input.
PE2/INT2	Input/Input		Remote control reception circuit input.	
PE3/INT3/ NMI	Input/Input/Input		14-bit PWM output.	
PE4/RMC	Input/Input		Output for the 16-bit timer/counter rectangular waves, and 32kHz oscillation frequency division.	
PE5	Input			
PE6/ \overline{PWM}	Output/Output			
PE7/TO/ADJ	Output/Output/ Output			
PF0/A47 to PF7/A40	Output/Output	(Port F) 8-bit output port. (8pins)	FDP segment signal (anode connection) outputs.	

Pin code	I/O	Functions	
PG0/A39 to PG7/A32	Output/Output	(Port G) 8-bit output port. (8 pins)	FDP segment signal (anode connection) outputs. (8 pins)
PH0/A31 to PH7/A24	Output/Output	(Port H) 8-bit output port. (8 pins)	FDP segment signal (anode connection) outputs. (8 pins)
A16 to A23	Output	FDP segment signal (anode connection) outputs. (8 pins)	
G0/A0 to G15/A15	Output/Output	Outputs for FDP timing signals (grid connection)/segment signals (anode connection). (16 pins)	
V _{FDP}		FDP voltage supply when incorporated pull-down (PD) resistor is set by mask option.	
EXTAL	Input	Crystal connectors for system clock oscillation. When the clock is supplied externally, input to EXTAL; opposite phase clock should be input to XTAL.	
XTAL	Output		
TEX	Input	Crystal connectors for 32kHz timer/counter clock oscillation. For usage as event input, input to TEX, and open TX.	
TX	Output		
$\overline{\text{RST}}$	Input	Low-level active, system reset	
NC		NC. Under normal operation, connect to V _{DD} .	
AV _{REF}	Input	Reference voltage input for A/D converter.	
AV _{SS}		A/D converter GND.	
V _{DD}		V _{CC} supply.	
V _{SS}		GND.	



November 1992
Revised April 1999

74VHC244

Octal Buffer/Line Driver with 3-STATE Outputs

General Description

The VHC244 is an advanced high speed CMOS octal bus buffer fabricated with silicon gate CMOS technology. It achieves high speed operation similar to equivalent Bipolar Schottky TTL while maintaining the CMOS low power dissipation. The VHC244 is a non-inverting 3-STATE buffer having two active-LOW output enables. These devices are designed to be used as 3-STATE memory address drivers, clock drivers, and bus oriented transmitter/receivers.

An input protection circuit ensures that 0V to 7V can be applied to the input pins without regard to the supply voltage. This device can be used to interface 5V to 3V systems and two supply systems such as battery back up. This cir-

cuit prevents device destruction due to mismatched supply and input voltages.

Features

- High Speed: $t_{PD} = 3.9\text{ns}$ (typ) at $V_{CC} = 5\text{V}$
- High noise immunity: $V_{NIH} = V_{NIL} = 28\% V_{CC}$ (min)
- Power down protection is provided on all inputs
- Low noise: $V_{OLP} = 0.6\text{V}$ (typ)
- Low power dissipation: $I_{CC} = 4\ \mu\text{A}$ (max) @ $T_A = 25^\circ\text{C}$
- Pin and function compatible with 74HC244

Ordering Code:

Order Number	Package Number	Package Description
74VHC244M	M20B	20-Lead Small Outline Integrated Circuit (SOIC), JEDEC MS-013, 0.300" Wide
74VHC244SJ	M20D	20-Lead Small Outline Package (SOP), EIAJ TYPE II, 5.3mm Wide
74VHC244MTC	MTC20	20-Lead Thin Shrink Small Outline Package (TSSOP), JEDEC MO-153, 4.4mm Wide
74VHC244N	N20A	20-Lead Plastic Dual-In-Line Package (PDIP), JEDEC MS-001, 0.300" Wide

Surface mount packages are also available on Tape and Reel. Specify by appending the suffix letter "X" to the ordering code.

Logic Symbol

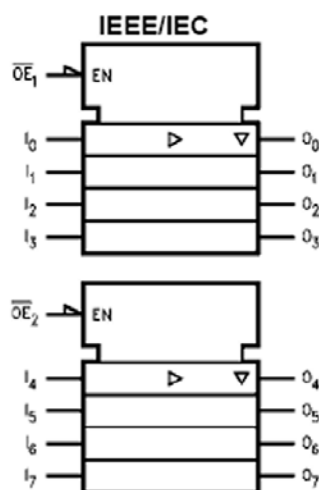

Connection Diagram

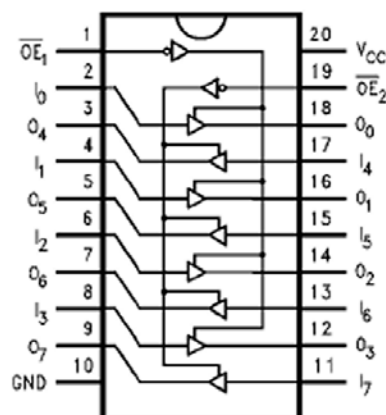

Pin Descriptions

Pin Names	Description
$\overline{OE}_1, \overline{OE}_2$	3-STATE Output Enable Inputs
I_0-I_7	Inputs
O_0-O_7	3-STATE Outputs

Truth Tables

Inputs		Outputs (Pins 12, 14, 16, 18)
\overline{OE}_1	I_n	
L	L	L
L	H	H
H	X	Z

Inputs		Outputs (Pins 3, 5, 7, 9)
\overline{OE}_2	I_n	
L	L	L
L	H	H
H	X	Z

H = HIGH Voltage Level
 L = LOW Voltage Level
 I = Immaterial
 Z = High Impedance

74VHC574

OCTAL D-TYPE FLIP FLOP WITH 3 STATE OUTPUTS NON INVERTING

- HIGH SPEED:
- $f_{MAX} = 180$ MHz (TYP.) at $V_{CC} = 5$ V
- LOW POWER DISSIPATION:
 $I_{CC} = 4$ μ A (MAX.) at $T_A = 25^\circ$ C
- HIGH NOISE IMMUNITY:
 $V_{NIH} = V_{NIL} = 28\%$ V_{CC} (MIN.)
- POWER DOWN PROTECTION ON INPUTS
- SYMMETRICAL OUTPUT IMPEDANCE:
 $|I_{OH}| = |I_{OL}| = 8$ mA (MIN)
- BALANCED PROPAGATION DELAYS:
 $t_{PLH} \approx t_{PHL}$
- OPERATING VOLTAGE RANGE:
 $V_{CC(OPR)} = 2$ V to 5.5 V
- PIN AND FUNCTION COMPATIBLE WITH 74 SERIES 574
- IMPROVED LATCH-UP IMMUNITY
- LOW NOISE: $V_{OLP} = 0.9$ V (MAX.)

DESCRIPTION

The 74VHC574 is an advanced high-speed CMOS OCTAL D-TYPE FLIP FLOP with 3 STATE OUTPUTS NON INVERTING fabricated with sub-micron silicon gate and double-layer metal wiring C²MOS technology.

These 8 bit D-Type flip-flop is controlled by a clock input (CK) and an output enable input (\overline{OE}).

On the positive transition of the clock, the Q outputs will be set to the logic states that were setup at the D inputs.

While the (\overline{OE}) input is low, the 8 outputs will be in a normal logic state (high or low logic level) and

PIN CONNECTION AND IEC LOGIC SYMBOLS

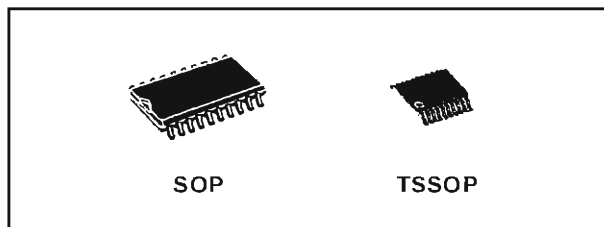
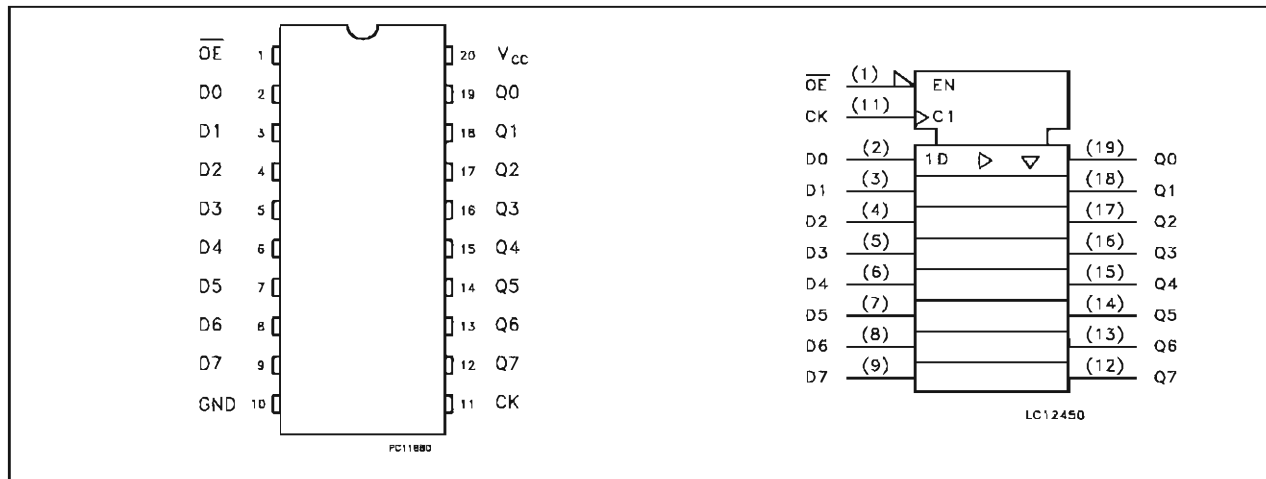

ORDER CODES

PACKAGE	TUBE	T & R
SOP	74VHC574M	74VHC574MTR
TSSOP		74VHC574TTR

while high level the outputs will be in a high impedance state.

The Output control does not affect the internal operation of flip flop; that is, the old data can be retained or the new data can be entered even while the outputs are off.

Power down protection is provided on all inputs and 0 to 7V can be accepted on inputs with no regard to the supply voltage. This device can be used to interface 5V to 3V.

All inputs and outputs are equipped with protection circuits against static discharge, giving them 2KV ESD immunity and transient excess voltage.

74VHC574

INPUT EQUIVALENT CIRCUIT

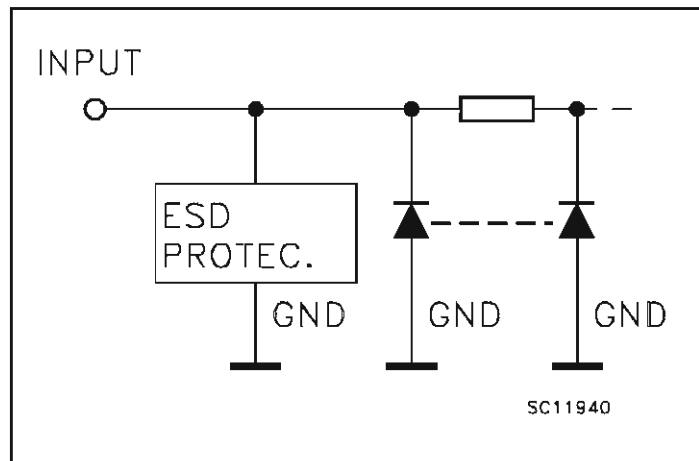

PIN DESCRIPTION

PIN No	SYMBOL	NAME AND FUNCTION
1	\overline{OE}	3-State Output Enable Input (Active LOW)
2, 3, 4, 5, 6, 7, 8, 9	D0 to D7	Data Inputs
12, 13, 14, 15, 16, 17, 18, 19	Q0 to Q7	3-State Outputs
11	CK	Clock Input (LOW-to-HIGH Edge Triggered)
10	GND	Ground (0V)
20	V _{CC}	Positive Supply Voltage

TRUTH TABLE

INPUTS			OUTPUT
\overline{OE}	CK	D	Q
H	X	X	Z
L		X	NO CHANGE
L		L	L
L		H	H

X : Don't Care
Z : High Impedance

LOGIC DIAGRAM

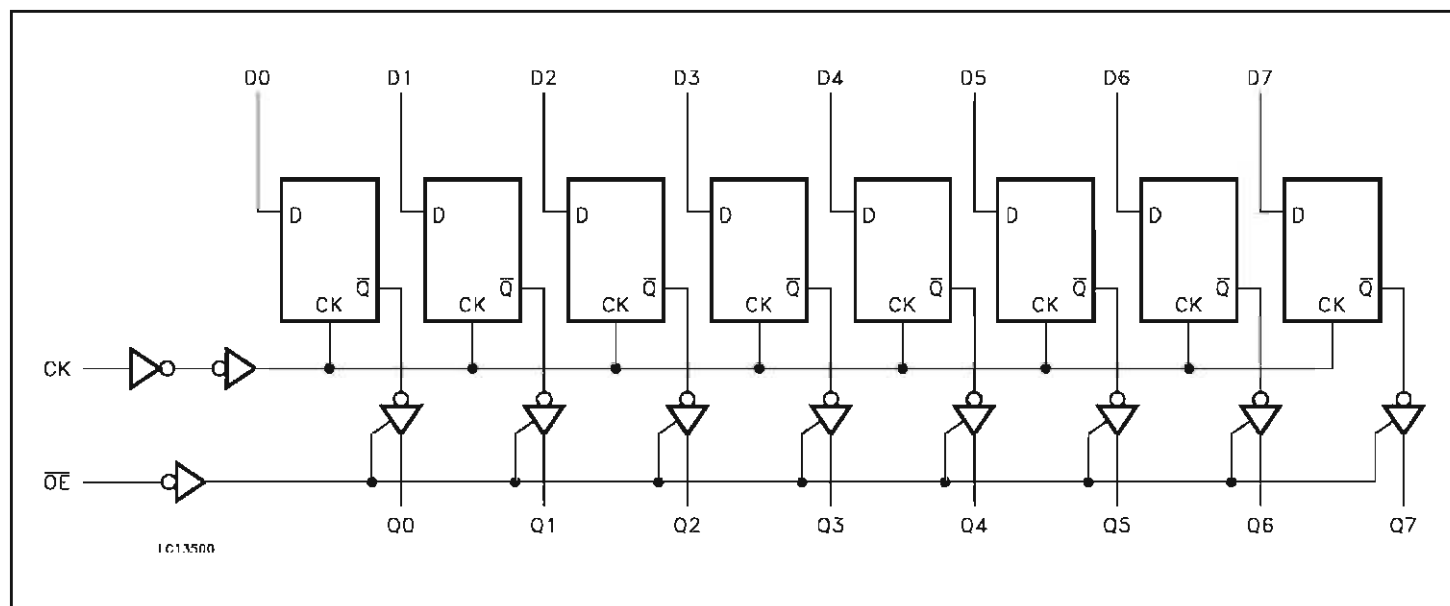

This logic diagram has not be used to estimate propagation delays

4Megabit Low Voltage OPT EPROM

AT27LV040A

TSOP, VSOP Top View
Type 1

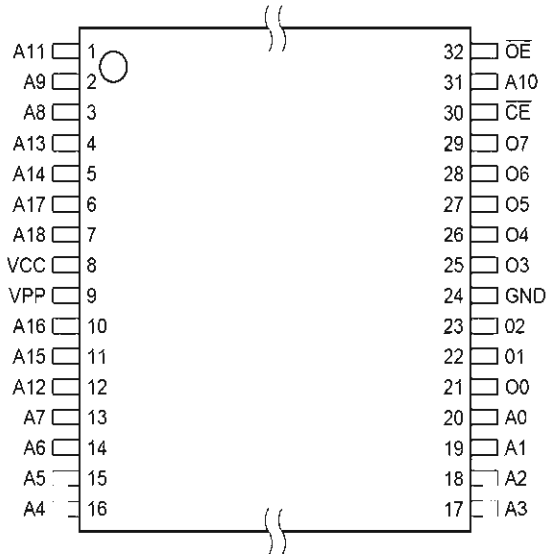
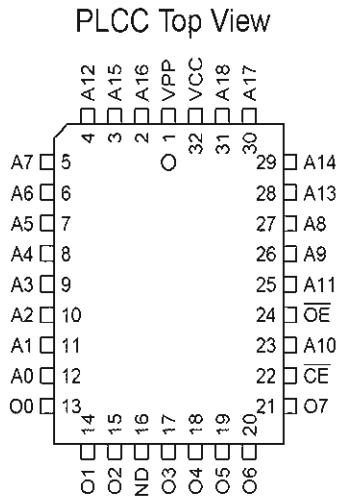

Pin Configuration

Pin Name	Function
A0 - A18	Addresses
O0 - O7	Outputs
\overline{CE}	Chip Enable
\overline{OE}	Output Enable

Block Diagram

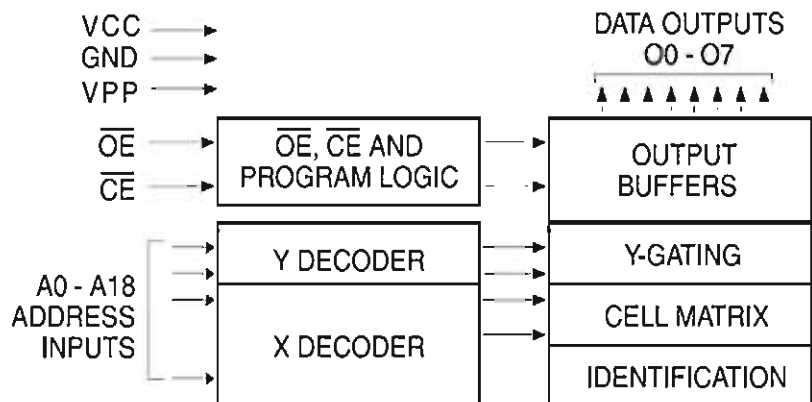

BA7046/BA7046F

SYNC Separator IC with AFC

● Block diagrams

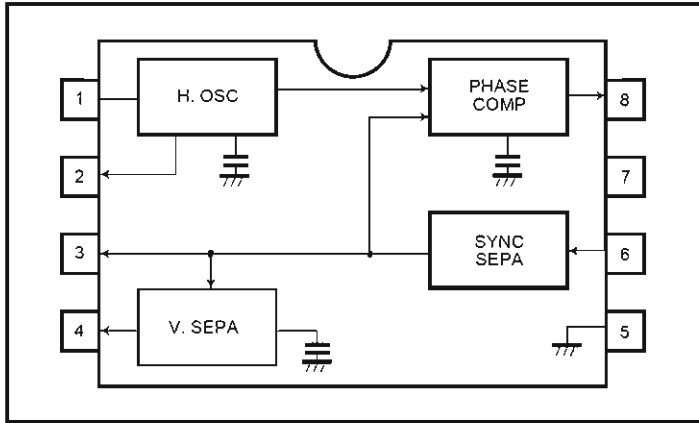

● Pin descriptions

Pin No.	Function
1	Horizontal oscillator resistor
2	H _b output
3	SYNC output (open collector)
4	V _D output
5	GND
6	Video input
7	Power supply
8	Phase comparator output

BA7046

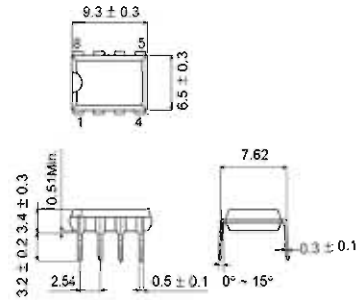

BA7046F

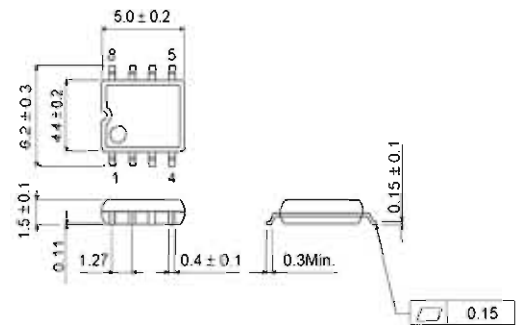

● Input / output circuits

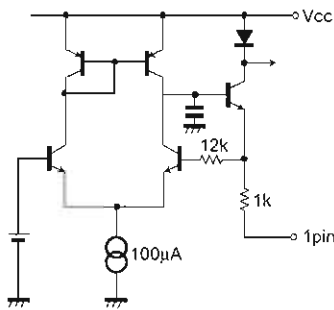

Fig. 1

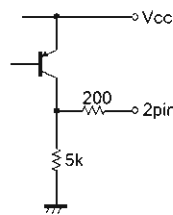

Fig. 2

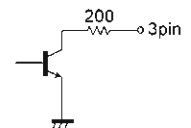

Fig. 3

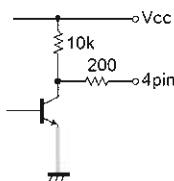

Fig. 4

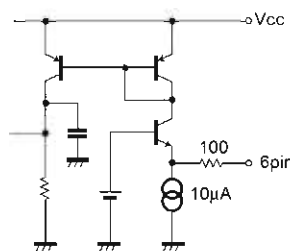

Fig. 5

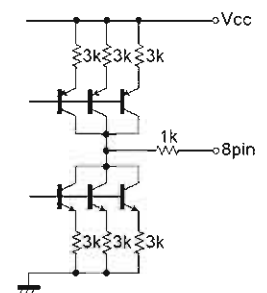

Fig. 6

8-channel analog multiplexer / demultiplexer

BU4051BC / BU4051BCF / BU4051BCFV

The BU4051BC, BU4051BCF and BU4051BCFV are analog multiplexers / demultiplexers which use three-input digital signals for control via an 8-channel analog switch.

These products feature high on / off output voltage ratio and low crosstalk between analog switches.

●Block diagram

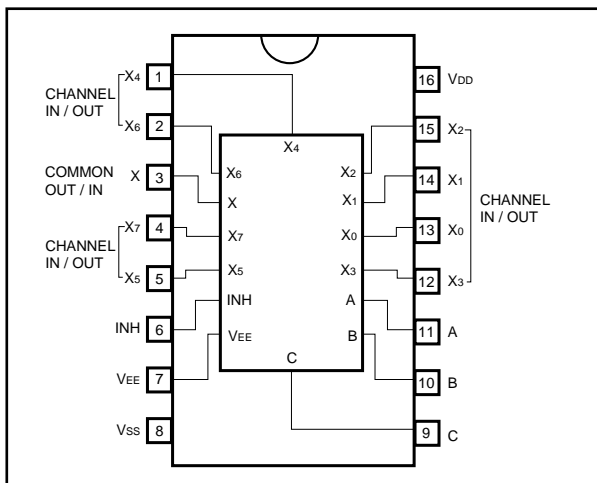

●Logic circuit diagram

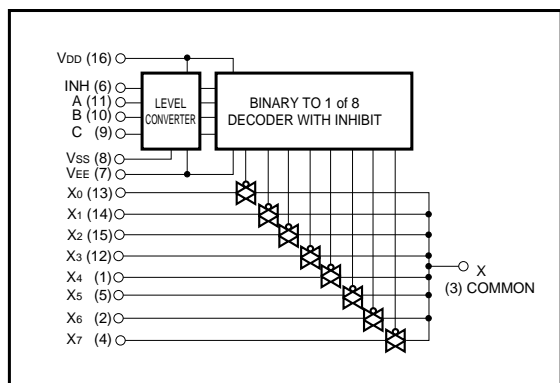

●Truth table

INH	A	B	C	ON SWITCH
L	L	L	L	X ₀
L	H	L	L	X ₁
L	L	H	L	X ₂
L	H	H	L	X ₃
L	L	L	H	X ₄
L	H	L	H	X ₅
L	L	H	H	X ₆
L	H	H	H	X ₇
H	X	X	X	NONE

X: Irrelevant

Triple 2-channel analog multiplexer / demultiplexer

BU4053BC / BU4053BCF / BU4053BCFV

The BU4053BC, BU4053BCF, and BU4053BCFV are multiplexers / demultiplexers capable of selecting and combining analog signals and digital signals in a 2 ch × 3 configuration. Inhibit signals and control signals are used to turn on the switch corresponding to each of the channels. In addition, even if the logical amplitude ($V_{DD}-V_{SS}$) of the control signal is low, signals with a large amplitude ($V_{DD}-V_{EE}$) can be switched.

Also, as each switch has a low ON resistance, it can be connected to a low impedance circuit.

●Block diagram

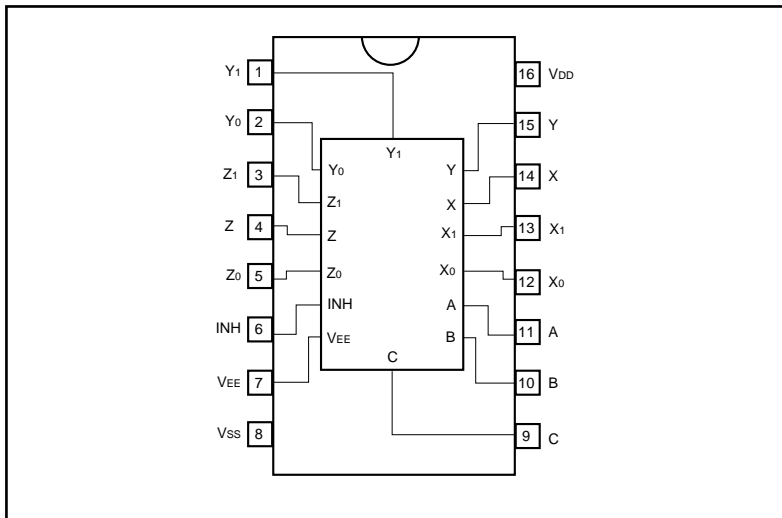

●Logic circuit diagram

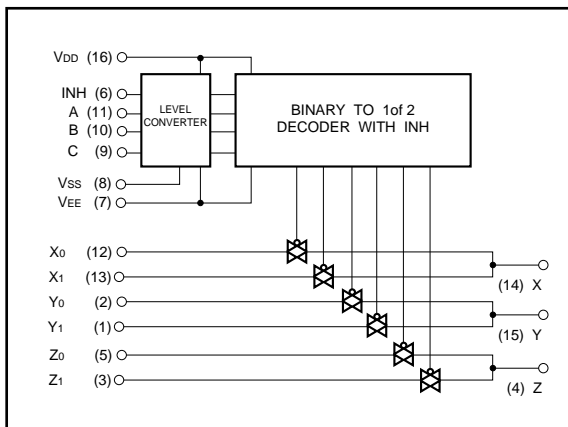

●Truth table

INH	A	B	C	ON SWITCH
L	L	L	L	X ₀ Y ₀ Z ₀
L	H	L	L	X ₁ Y ₀ Z ₀
L	L	H	L	X ₀ Y ₁ Z ₀
L	H	H	L	X ₁ Y ₁ Z ₀
L	L	L	H	X ₀ Y ₀ Z ₁
L	H	L	H	X ₁ Y ₀ Z ₁
L	L	H	H	X ₀ Y ₁ Z ₁
L	H	H	H	X ₁ Y ₁ Z ₁
H	X	X	X	NONE

X: Irrelevant

8-bit compatible shift / store register BU4094BC / BU4094BCF / BU4094BCFV

The BU4094BC, BU4094BCF, and BU4094BCFV are shift / store registers, each consisting of an 8-bit register and an 8-bit latch.

As the data in the shift register can be latched by an asynchronous strobe input, it is possible to hold the output in the data transfer mode.

The tri-state parallel output can be connected directly with an 8-bit bus line.

These registers are suitable for in-line / parallel data conversion, data receivers and other similar applications.

●Logic circuit diagram

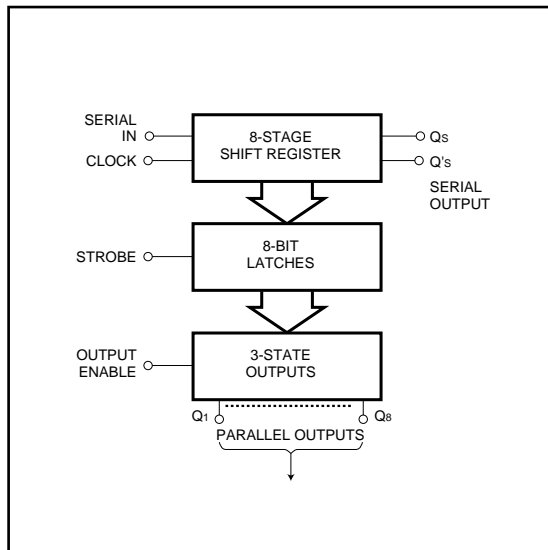

●Block diagram

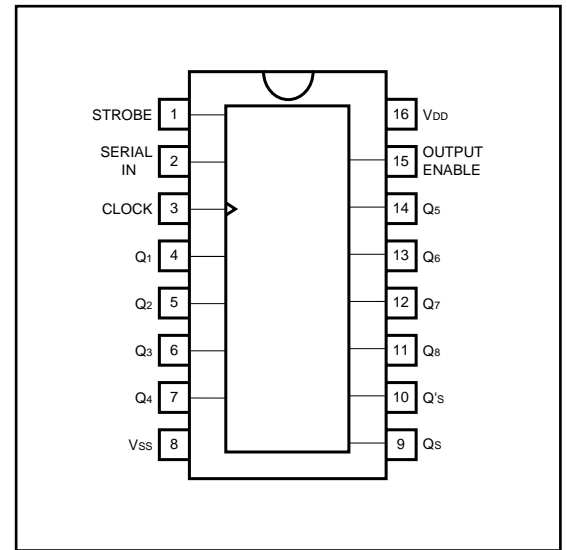

●Truth table

CLOCK	OUTPUT ENABLE	STROBE	SERIAL IN	Parallel output		Serial output	
				Q ₁	Q _n	Q _s	Q' _s
\downarrow	H	H	L	L	Q _{n-1}	Q ₇	NC
\downarrow	H	H	H	H	Q _{n-1}	Q ₇	NC
\downarrow	H	L	X	NC	NC	Q ₇	NC
\downarrow	L	X	X	Z	Z	Q ₇	NC
\uparrow	H	X	X	NC	NC	NC	Q _s
\uparrow	L	X	X	Z	Z	NC	Q _s

NC: No Change Z: High Impedance X: Irrelevant

CS4382

114 dB, 192 kHz 8-Channel D/A Converter

Features

- 24-Bit Conversion
- Up to 192 kHz Sample Rates
- 114 dB Dynamic Range
- -100 dB THD+N
- Supports PCM and DSD Data Formats
- Selectable Digital Filters
- Volume Control with Soft Ramp
 - 1 dB Step Size
 - Zero Crossing Click-Free Transitions
- Dedicated DSD inputs
- Low Clock Jitter Sensitivity
- Simultaneous Support for Two Synchronous Sample Rates for DVD Audio
- μ C or Stand-Alone Operation

Description

The CS4382 is a complete 8-channel digital-to-analog system including digital interpolation, fifth-order delta-sigma digital-to-analog conversion, digital de-emphasis, volume control and analog filtering. The advantages of this architecture include: ideal differential linearity, no distortion mechanisms due to resistor matching errors, no linearity drift over time and temperature and a high tolerance to clock jitter.

The CS4382 accepts PCM data at sample rates from 4 kHz to 192 kHz, DSD audio data, and operates over a wide power supply range. These features are ideal for multi-channel audio systems including DVD players, SACD players, A/V receivers, digital TV's and VCR's, mixing consoles, effects processors, set-top boxes, and automotive audio systems.

ORDERING INFORMATION

CS4382-KQZ, Lead Free	-10 to 70 °C	48-pin LQFP
CS4382-BQ	-40 to 85 °C	48-pin LQFP
CDB4382		Evaluation Board

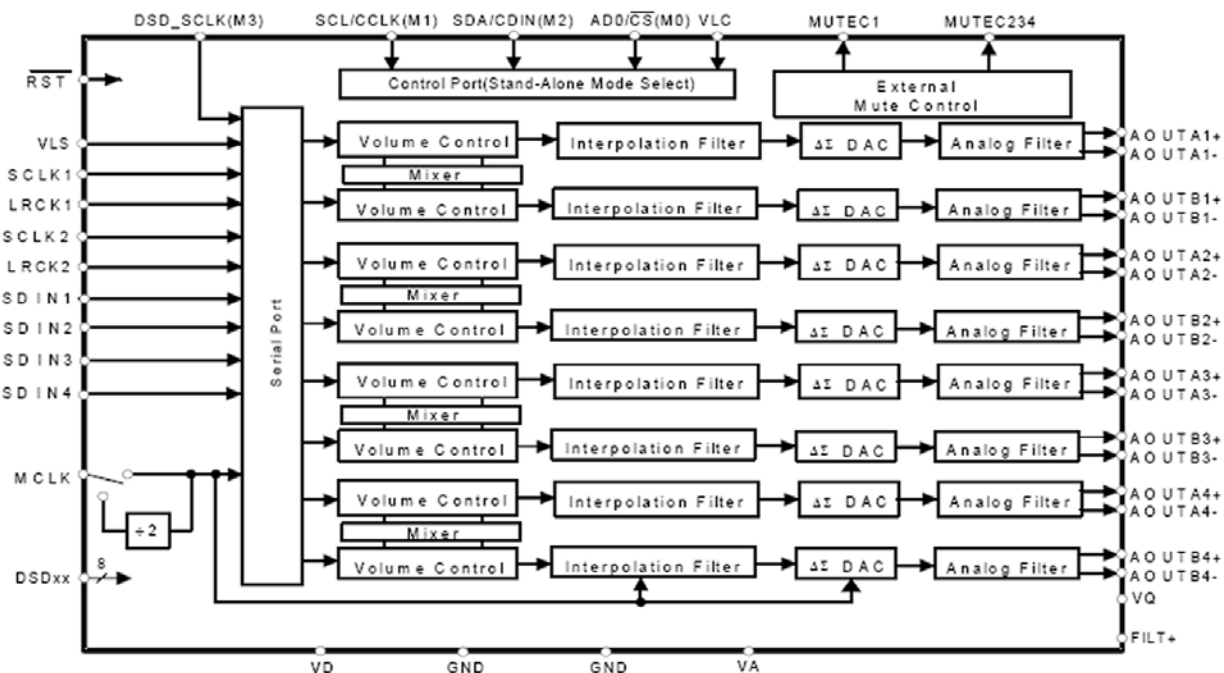

Preliminary Product Information

This document contains information for a new product. Cirrus Logic reserves the right to modify this product without notice.



CS4382

4. PIN DESCRIPTION

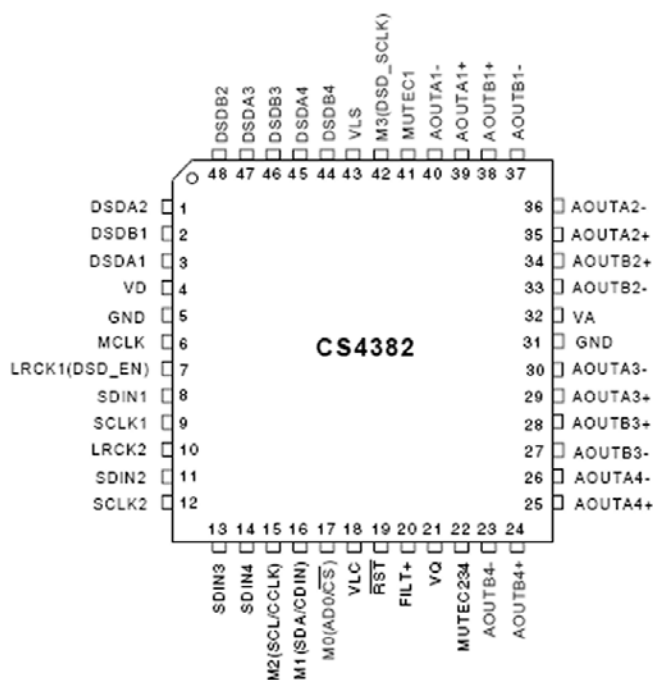

Pin Name	#	Pin Description
VD	4	Digital Power (Input) - Positive power supply for the digital section. Refer to the Recommended Operating Conditions for appropriate voltages.
GND	5 31	Ground (Input) - Ground reference. Should be connected to analog ground.
MCLK	6	Master Clock (Input) - Clock source for the delta-sigma modulator and digital filters. Table 5 illustrates several standard audio sample rates and the required master clock frequency.
LRCK1 LRCK2	7 10	Left Right Clock (Input) - Determines which channel, Left or Right, is currently active on the serial audio data line. The frequency of the left/right clock must be at the audio sample rate, F_s .
SDIN1 SDIN2 SDIN3 SDIN4	8 11 13 14	Serial Audio Data Input (Input) - Input for two's complement serial audio data.
SCLK1 SCLK2	9 12	Serial Clock (Input) - Serial clock for the serial audio interface.
VLC	18	Control Port Power (Input) - Determines the required signal level for the control port. Refer to the Recommended Operating Conditions for appropriate voltages.
RST	19	Reset (Input) - The device enters a low power mode and all internal registers are reset to their default settings when low.
FILT+	20	Positive Voltage Reference (Output) - Positive reference voltage for the internal sampling circuits. Requires the capacitive decoupling to analog ground, as shown in the Typical Connection Diagram.
VQ	21	Quiescent Voltage (Output) - Filter connection for internal quiescent voltage. VQ must be capacitively coupled to analog ground, as shown in the Typical Connection Diagram. The nominal voltage level is specified in the Analog Characteristics and Specifications section. VQ presents an appreciable source impedance and any current drawn from this pin will alter device performance. However, VQ can be used to bias the analog circuitry assuming there is no AC signal component and the DC current is less than the maximum specified in the Analog Characteristics and Specifications section.



CS4382

Pin Name	#	Pin Description
MUTEC1	41	Mute Control (Output) - The Mute Control pins go high during power-up initialization, reset, muting, power-down or if the master clock to left/right clock frequency ratio is incorrect. These pins are intended to be used as a control for external mute circuits to prevent the clicks and pops that can occur in any single supply system. The use of external mute circuits are not mandatory but may be desired for designs requiring the absolute minimum in extraneous clicks and pops.
MUTEC234	22	
AOUTA1 +,-	39, 40	Differential Analog Output (Output) - The full scale differential analog output level is specified in the Analog Characteristics specification table.
AOUTB1 +,-	38, 37	
AOUTA2 +,-	35, 36	
AOUTB2 +,-	34, 33	
AOUTA3 +,-	29, 30	
AOUTB3 +,-	28, 27	
AOUTA4 +,-	25, 26	
AOUTB4 +,-	24, 23	
VA	32	Analog Power (Input) - Positive power supply for the analog section. Refer to the Recommended Operating Conditions for appropriate voltages.
VLS	43	Serial Audio Interface Power (Input) - Determines the required signal level for the serial audio interface. Refer to the Recommended Operating Conditions for appropriate voltages.

Control Port Definitions

SCL/CCLK	15	Serial Control Port Clock (Input) - Serial clock for the serial control port. Requires an external pull-up resistor to the logic interface voltage in I ² C mode as shown in the Typical Connection Diagram.
SDA/CDIN	16	Serial Control Data (Input/Output) - SDA is a data I/O line in I ² C mode and requires an external pull-up resistor to the logic interface voltage, as shown in the Typical Connection Diagram. CDIN is the input data line for the control port interface in SPI mode.
AD0/ $\overline{\text{CS}}$	17	Address Bit 0 (I²C) / Control Port Chip Select (SPI) (Input) - AD0 is a chip address pin in I ² C mode; $\overline{\text{CS}}$ is the chip select signal for SPI format.

Stand-Alone Definitions

M0	17	Mode Selection (Input) - Determines the operational mode of the device as detailed in Tables 6 and 7.
M1	16	
M2	15	
M3	42	

DSD Definitions

DSD_SCLK	42	DSD Serial Clock (Input) - Serial clock for the Direct Stream Digital audio interface.
DSD_EN	7	DSD-Enable (Input) - When held at logic '1' the device will enter DSD mode (Stand-Alone mode only).
DSDA1	3	Direct Stream Digital Input (Input) - Input for Direct Stream Digital serial audio data.
DSDB1	2	
DSDA2	1	
DSDB2	48	
DSDA3	47	
DSDB3	46	
DSDA4	45	
DSDB4	44	

24-Bit Multi Standard
Audio DSP Decoder

CS493263

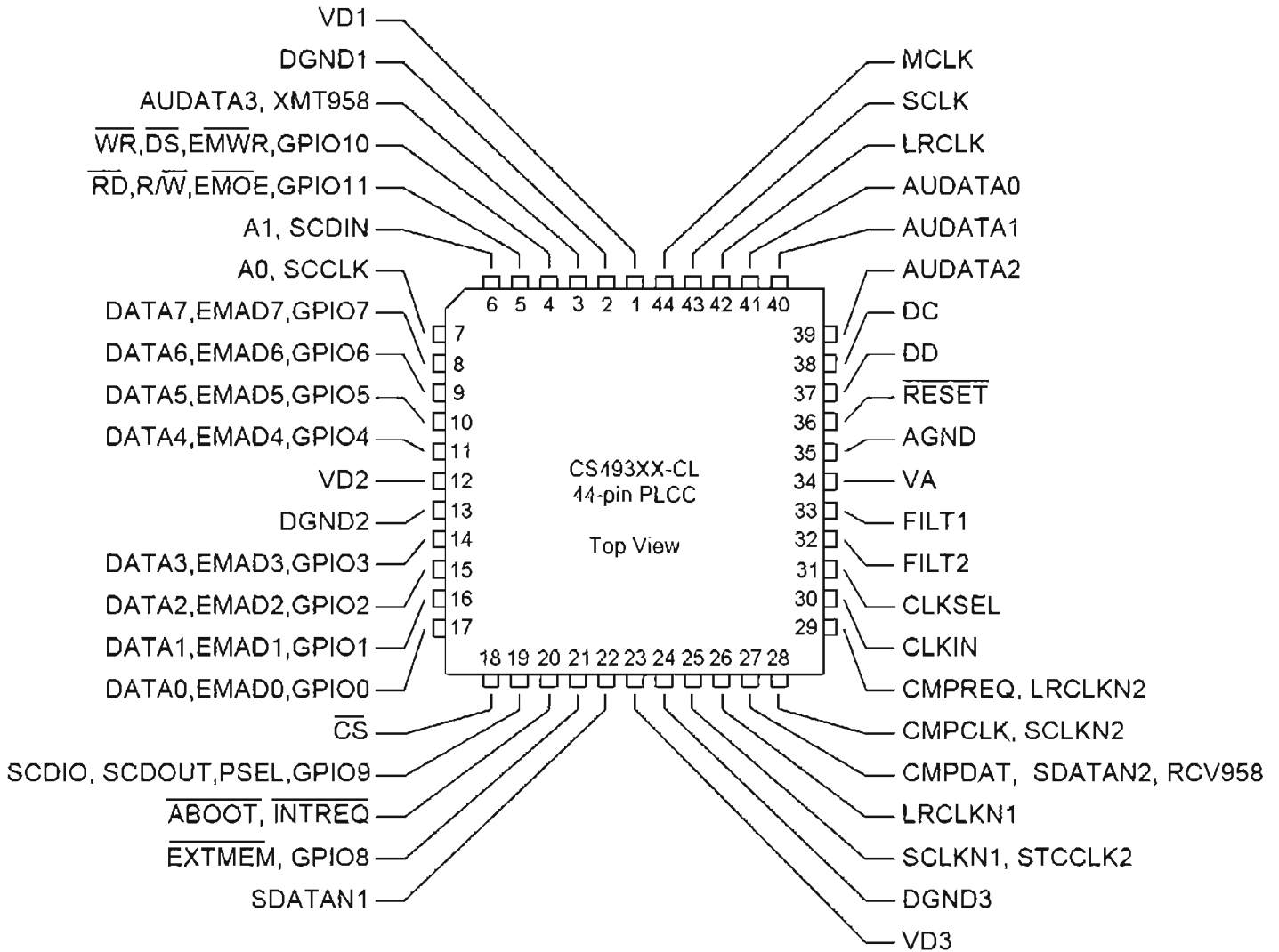



CS5360

24-Bit Stereo A/D Converter for Digital Audio

Features

- 24 Bit Conversion
- 105 dB Dynamic Range
- -95 dB THD+N
- 128X Oversampling
- Fully Differential Inputs
- Linear Phase Digital Anti-Alias Filtering
 - 21.7 kHz passband ($F_s = 48\text{kHz}$)
 - 85 dB stop band attenuation
 - 0.0025 dB pass band ripple
- High Pass Filter - DC Offset Removal
- Peak Signal Level Detector
 - High Resolution and Bar Graph Modes
- Pin Compatible with CS5334 and CS5335

Description

The CS5360 is a 2-channel, single +5 V supply, 24-bit analog-to-digital converter for digital audio systems. The CS5360 performs sampling, analog-to-digital conversion and anti-alias filtering, generating 24-bit values for both left and right inputs in serial form. The output word rate can be up to 50 kHz per channel.

The CS5360 uses 4th-order, delta-sigma modulation with 128X oversampling followed by digital filtering and decimation, which removes the need for an external anti-alias filter. This ADC uses a differential architecture which provides excellent noise rejection.

The CS5360 has a filter passband to 21.7 kHz. The filter has linear phase, 0.0025 dB passband ripple, and >85 dB stopband rejection. An on-chip high pass filter is also included to remove DC offsets.

ORDERING INFORMATION

CS5360-KS	-10° to 70°C	20-pin Plastic SSOP
CS5360-BS	-40° to 85°C	20-pin Plastic SSOP

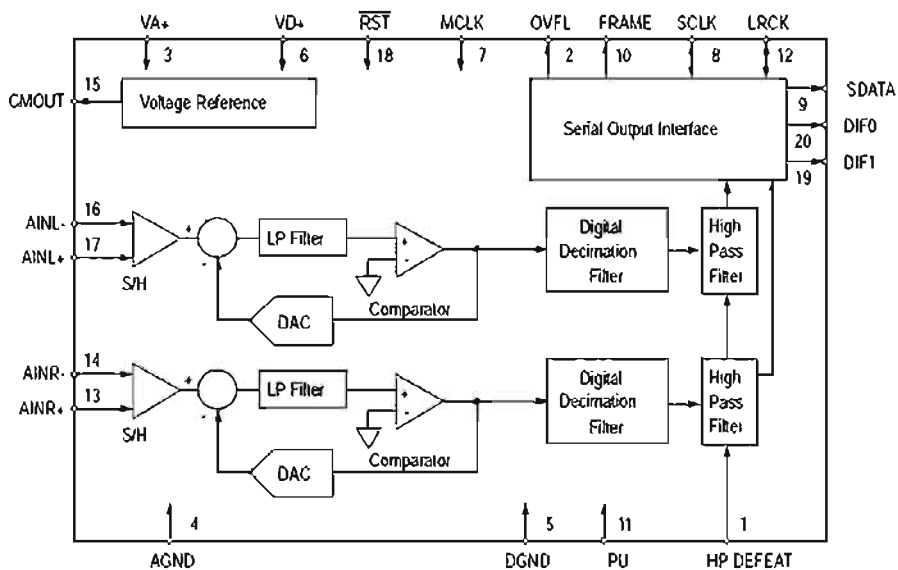



CS5360

5. PIN DESCRIPTIONS

High Pass Filter Defeat	HPDEFEAT	1	20	DIF0	Digital Interface Format 0
Overflow	OVFL	2	19	DIF1	Digital Interface Format 1
Analog Power	VA+	3	18	$\overline{\text{RST}}$	Reset
Analog Ground	AGND	4	17	AINL+	Non-Inverting Left Channel Input
Digital Ground	DGND	5	16	AINL-	Inverting Left Channel Input
Digital Power	VD+	6	15	CMOUT	Common Mode Output
Master Clock	MCLK	7	14	AINR-	Inverting Right Channel Input
Serial Data Clock	SCLK	8	13	AINR+	Non-Inverting Right Channel Input
Serial Data Output	SDATA	9	12	LRCK	Left / Right Clock
Frame Signal	FRAME	10	11	PU	Peak Update

High Pass Filter Defeat - HP DEFEAT

Pin 1, Input

Function

A high logic level on this pin disables the digital high pass filter. A low logic level on this pin enables the high pass filter.

Overflow - $\overline{\text{OVFL}}$

Pin 2, Input

Function

Overflow indicates analog input overrange, for both the Left and Right channels, since the last update request on the PEAK UPDATE (PU) pin. A value of 1 in the register indicates an overrange condition. The left channel information is output on $\overline{\text{OVFL}}$ during the left channel portion of LRCK. The right channel information is available on $\overline{\text{OVFL}}$ during the right channel portion of LRCK. The registers are updated with a high to low transition on the PEAK UPDATE pin. A 47 k Ω pull-down resistor on this pin will set the CS5360 in Master Mode.

Positive Analog Power - VA+

Pin 3, Input

Function:

Positive analog supply. Nominally +5 volts.

Analog Ground - AGND

Pin 4, Input

Function:

Analog ground reference.

DGND - Digital Ground

Pin 5, Input

Function:

Digital ground reference.



CS5360

Positive Digital Power - VD+*Pin 6, Input**Function:*

Positive digital supply. Nominally +5 volts.

Master Clock - MCLK*Pin 7, Input**Function:*

Clock source for the delta-sigma modulator sampling and digital filters. In Master Mode, the frequency of this clock must be 256x the output sample rate, F_s . In Slave Mode, the frequency of this clock must be either 256x, 384x or 512x F_s .

Serial Data Clock - SCLK*Pin 8, Input/Output**Function:*

Clocks the individual bits of the serial data out from the SDATA pin. The relationship between LRCK, SCLK and SDATA is controlled by DIF0 and DIF1. In Master Mode, SCLK is an output clock with a frequency of 64x the output sample rate, F_s . In Slave Mode, SCLK is an input.

Serial Data Output - SDATA*Pin 9, Output**Function:*

Two's complement MSB-first serial data of 24 bits is output on this pin. Included in the serial data output is the 8-bit Input Signal Level Bits. The data is clocked out via the SCLK clock and the channel is determined by LRCK. The relationship between LRCK, SCLK and SDATA is controlled by DIF0 and DIF1.

Peak Update - PU*Pin 11, Input**Function:*

Transfers the Peak Signal Level contents of the Active Registers to the Output Registers on a high to low transition on this pin. This transition will also reset the Active register.

Frame Signal - FRAME*Pin 10, Output**Function:*

Frames the Peak Signal Level (PSL) Bits. FRAME goes high coincident with the leading edge of the first PSL bit and falls coincident with the trailing edge of the last PSL bit as shown in Figures 8-10. A 47 k Ω pull-down resistor on this pin will set the Peak Signal Level Monitoring format to "Bar Graph" mode.

Left/Right Clock - LRCK*Pin 12, Input/Output**Function:*

LRCK determines which channel, left or right, is to be output on SDATA. The relationship between LRCK, SCLK and SDATA is controlled by DIF0 and DIF1. Although the outputs for each channel are transmitted at different times, Left/Right pairs represent simultaneously sampled analog inputs. In Master Mode, LRCK is an output clock whose frequency is equal to the output sample rate, F_s . In Slave Mode, LRCK is an input clock whose frequency must be equal to F_s .



CS5360

Differential Right Channel Analog Input - AINR+, AINR-*Pin 13 and Pin 14, Input**Function:*

Analog input connections of the right channel differential inputs. Typically 2 Vrms differential (1Vrms for each input pin) for a full-scale analog input signal.

Common Mode Output - CMOUT*Pin 15, Output**Function:*

This output, nominally 2.2 V, can be used to bias the analog input circuitry to the common mode voltage of the CS5360. CMOUT is not buffered and the maximum current is 10 μ A.

Differential Left Channel Analog Input - AINL+, AINL-*Pin 16 and Pin 17, Input**Function:*

Analog input connections of the left channel differential inputs. Typically 2 Vrms differential (1Vrms for each input pin) for a full-scale analog input signal.

Reset - $\overline{\text{RST}}$ *Pin 18, Input**Function:*

A low logic level on this pin activates Reset.

Digital Interface Format - DIF0, DIF1*Pins 19 and 20, Input**Function:*

These two pins select one of 3 digital interface formats or power-down. The format determines the relationship between SCLK, LRCK and SDATA. The formats are detailed in Figures 8-10.

mitsumi

Video Switch · 75Ω driver · Y/C mix MM1501

Video Switch · 75Ω driver · Y/C mix Monolithic IC MM1501 Series

Outline

This IC extends the series of ICs for video/audio signal switching, with a 2-input 1-output single video switch, video signal/chroma signal 75Ω driver, and Y/C mixing circuit in one small package (SOT-26).

Features

- (1) Low power consumption achieved.
- (2) Low power supply voltage realized.
- (3) Frequency bandwidth without 75Ω driver: 10MHz with 75Ω driver: 7MHz
- (4) Cross talk 70dB When 4.43MHz
- (5) With SAG measures pin (75Ω driver and Y/C mix driver)

Package

- SOT-26A (with 75Ω driver)
- SOT-26B (without 75Ω driver)

Applications

- (1) TV
- (2) VTR
- (3) Video camera
- (4) Digital still camera
- (5) Other visual equipment

Line-up

Functions	Model Name	Input	Output	Clamp	6dB amp	75Ω driver	SAG measures pin	Power supply voltage
Switch	MM1501	2	1	×	×	×	×	4.5~13.0V
	MM1502			×	○	×	×	4.5~13.0V
	MM1503			○	×	×	×	4.5~13.0V
	MM1504			○	○	×	×	4.5~13.0V
	MM1505			×	×	○	×	4.5~13.0V
	MM1506			×	○	○	×	4.5~13.0V
	MM1507			○	×	○	×	4.5~13.0V
	MM1508			○	○	○	×	4.5~13.0V
Driver	MM1509	1	1	×	○	○	○	4.5~13.0V
	MM1510			○	○	○	○	4.5~13.0V
Y/C mix	MM1511	1	1	○/×	×	×	×	4.5~13.0V
	MM1512			○/×	○	○	○	4.5~13.0V

Block Diagram

■ MM1501

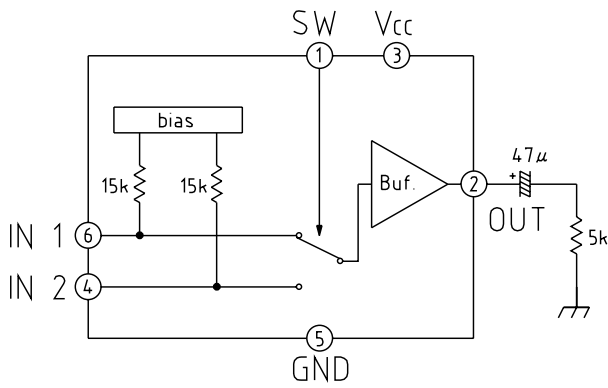

■ MM1505

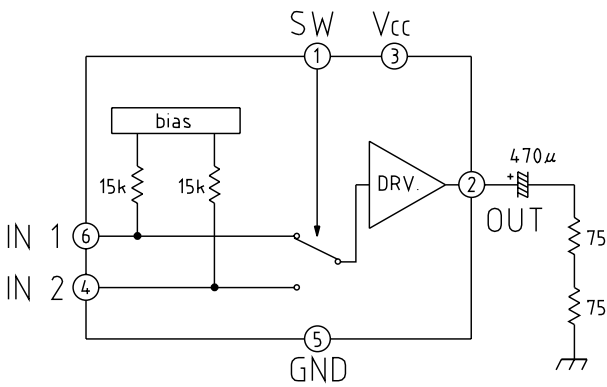

■ MM1511

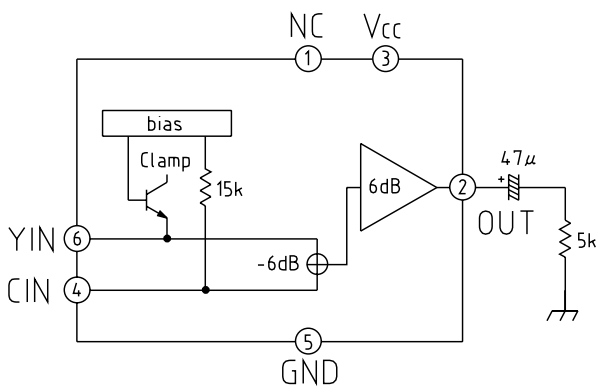

Absolute Maximum Ratings (Ta=25°C)

Item	Symbol	Rating	Unit	
Storage temperature	T _{STG}	-40~+125	°C	
Operating temperature	T _{OPR}	-30~+75	°C	
Power supply voltage	V _{CC}	15	V	
Allowable loss	When alone	P _d	200	mW
	When mounted on board	P _d	350 (★)	mW

*Board size 100mm×100mm t=1.6

Recommended Operating Conditions

Item	Symbol	Rating	Unit
Power supply voltage	V _{CC}	4.5~13	V

Electrical Characteristics (Except where noted otherwise, Ta=25°C, V_{CC}=5V)

■ MM1501

Item	Symbol	Measurement conditions	Min.	Typ.	Max.	Unit
Consumption current	I _{CC}	Refer to measurement procedures		3.7	4.8	mA
Input pin voltage	V _{IN}	No-signal, no-load	2.70	2.90	3.10	V
Output pin voltage	V _{OUT}	No-signal, no-load		2.15		V
Voltage gain	G _V	Refer to measurement procedures	-0.5	0	+0.5	dB
Frequency characteristic	f _c	Refer to measurement procedures	-1	0	+1	dB
Differential gain	V _{CC} =9V DG	Refer to measurement procedures	-3	0	+3	%
Differential phase	V _{CC} =9V DP	Refer to measurement procedures	-3	0	+3	deg
Total harmonic distortion ratio	THD	Refer to measurement procedures		0.03	0.3	%
Output dynamic range	V _D	Refer to measurement procedures	3.5	3.8		V
Output offset voltage	V _{OFF}	Refer to measurement procedures			±15	mV
Cross talk	C _T	Refer to measurement procedures		-70	-60	dB
SW input voltage H	V _{IH}	Refer to measurement procedures	2.1			V
SW input voltage L	V _{IL}	Refer to measurement procedures			0.7	V
Input impedance	Z _i			15		kΩ
Output impedance	Z _o			75		Ω

■ MM1502

Item	Symbol	Measurement conditions	Min.	Typ.	Max.	Unit
Consumption current	I _{CC}	Refer to measurement procedures		4.7	6.1	mA
Input pin voltage	V _{IN}	No-signal, no-load	1.70	1.90	2.10	V
Output pin voltage	V _{OUT}	No-signal, no-load		2.10		V
Voltage gain	G _V	Refer to measurement procedures	5.5	6.0	6.5	dB
Frequency characteristic	f _c	Refer to measurement procedures	-1	0	+1	dB
Differential gain	V _{CC} =9V DG	Refer to measurement procedures	-3	0	+3	%
Differential phase	V _{CC} =9V DP	Refer to measurement procedures	-3	0	+3	deg
Total harmonic distortion ratio	THD	Refer to measurement procedures		0.03	0.3	%
Output dynamic range	V _D	Refer to measurement procedures	3.5	3.8		V
Output offset voltage	V _{OFF}	Refer to measurement procedures			±30	mV
Cross talk	C _T	Refer to measurement procedures		-70	-60	dB
SW input voltage H	V _{IH}	Refer to measurement procedures	2.1			V
Sw input voltage L	V _{IL}	Refer to measurement procedures			0.7	V
Input impedance	Z _i			15		kΩ
Output impedance	Z _o			12		Ω

■ MM1503

Item	Symbol	Measurement conditions	Min.	Typ.	Max.	Unit
Consumption current	I _{CC}	Refer to measurement procedures		3.3	4.3	mA
Input pin voltage	V _{IN}	No-signal, no-load	1.80	2.00	2.20	V
Output pin voltage	V _{OUT}	No-signal, no-load		1.25		V
Voltage gain	G _V	Refer to measurement procedures	-0.5	0	+0.5	dB
Frequency characteristic	f _c	Refer to measurement procedures	-1	0	+1	dB
Differential gain	DG	Refer to measurement procedures	-3	0	+3	%
Differential phase	DP	Refer to measurement procedures	-3	0	+3	deg
Total harmonic distortion ratio	THD	Refer to measurement procedures		0.03	0.3	%
Output dynamic range	V _D	Refer to measurement procedures	2.6	2.9		V
Output offset voltage	V _{OFF}	Refer to measurement procedures			±15	mV
Cross talk	C _T	Refer to measurement procedures		-70	-60	dB
SW input voltage H	V _{IH}	Refer to measurement procedures	2.1			V
SW input voltage L	V _{IL}	Refer to measurement procedures			0.7	V
Input impedance	Z _O			75		Ω

■ MM1504

Item	Symbol	Measurement conditions	Min.	Typ.	Max.	Unit
Consumption current	I _{CC}	Refer to measurement procedures		4.4	5.7	mA
Input pin voltage	V _{IN}	No-signal, no-load	1.20	1.40	1.60	V
Output pin voltage	V _{OUT}	No-signal, no-load		1.25		V
Voltage gain	G _V	Refer to measurement procedures	5.5	6.0	6.5	dB
Frequency characteristic	f _c	Refer to measurement procedures	-1	0	+1	dB
Differential gain	DG	Refer to measurement procedures	-3	0	+3	%
Differential phase	DP	Refer to measurement procedures	-3	0	+3	deg
Total harmonic distortion ratio	THD	Refer to measurement procedures		0.03	0.3	%
Output dynamic range	V _D	Refer to measurement procedures	2.6	2.9		V
Output offset voltage	V _{OFF}	Refer to measurement procedures			±30	mV
Cross talk	C _T	Refer to measurement procedures		-70	-60	dB
SW input voltage H	V _{IH}	Refer to measurement procedures	2.1			V
SW input voltage L	V _{IL}	Refer to measurement procedures			0.7	V
Input impedance	Z _O			12		Ω

■ MM1505

Item	Symbol	Measurement conditions	Min.	Typ.	Max.	Unit
Consumption current	I _{CC}	Refer to measurement procedures		6.5	8.5	mA
Input pin voltage	V _{IN}	No-signal, no-load	2.35	2.55	2.75	V
Output pin voltage	V _{OUT}	No-signal, no-load		2.55		V
Voltage gain	G _V	Refer to measurement procedures	-0.5	0.0	0.5	dB
Frequency characteristic	f _c	Refer to measurement procedures	-1	0	+1	dB
Differential gain	V _{CC=9V} DG	Refer to measurement procedures	-3	0	+3	%
Differential phase	V _{CC=9V} DP	Refer to measurement procedures	-3	0	+3	deg
Output dynamic range	V _D	Refer to measurement procedures	2.6	3.0		V
Output offset voltage	V _{OFF}	Refer to measurement procedures			±15	mV
Cross talk	C _T	Refer to measurement procedures		-70	-60	dB
SW input voltage H	V _{IH}	Refer to measurement procedures	2.1			V
SW input voltage L	V _{IL}	Refer to measurement procedures			0.7	V
Input impedance	Z _i			15		kΩ

mitsumi

Video Switch · 75Ω driver · Y/C mix MM1501

■ MM1509

Item	Symbol	Measurement conditions	Min.	Typ.	Max.	Unit
Consumption current	I _{CC1}	Refer to measurement procedures		6.3	8.2	mA
Current consumption for PS	I _{CC2}	Refer to measurement procedures		20	30	μA
PS input voltage L	V _{PSL}	Refer to measurement procedures			0.3	V
PS input voltage H	V _{PSH}	Refer to measurement procedures	1.8			V
Input pin voltage	V _{IN}	No-signal, no-load	1.75	1.95	2.15	V
Output pin voltage	V _{OUT}	No-signal, no-load		2.35		V
Voltage gain	G _V	Refer to measurement procedures	5.5	6.0	6.5	dB
Frequency characteristic	f _c	Refer to measurement procedures	-1	0	+1	dB
Differential gain	V _{CC=9V} DG	Refer to measurement procedures	-3	0	+3	%
Differential phase	V _{CC=9V} DP	Refer to measurement procedures	-3	0	+3	deg
Output dynamic range	V _D	Refer to measurement procedures	2.9	3.2		V
Input impedance	Z _i			15		kΩ

■ MM1510

Item	Symbol	Measurement conditions	Min.	Typ.	Max.	Unit
Consumption current	I _{CC1}	Refer to measurement procedures		6.4	8.3	mA
Current consumption for PS	I _{CC2}	Refer to measurement procedures		20	30	μA
PS input voltage L	V _{PSL}	Refer to measurement procedures			0.3	V
PS input voltage H	V _{PSH}	Refer to measurement procedures	1.8			V
Input pin voltage	V _{IN}	No-signal, no-load	1.15	1.35	1.55	V
Output pin voltage	V _{OUT}	No-signal, no-load		1.15		V
Voltage gain	G _V	Refer to measurement procedures	5.5	6.0	6.5	dB
Frequency characteristic	f _c	Refer to measurement procedures	-1	0	+1	dB
Differential gain	DG	Refer to measurement procedures	-3	0	+3	%
Differential phase	DP	Refer to measurement procedures	-3	0	+3	deg
Output dynamic range	V _D	Refer to measurement procedures	2.6	3.0		V

■ MM1511

Item	Symbol	Measurement conditions	Min.	Typ.	Max.	Unit
Consumption current	I _{CC}	Refer to measurement procedures		4.4	5.7	mA
Y input pin voltage	V _{YIN}	No-signal, no-load	2.00	2.20	2.40	V
C input pin voltage	V _{CIN}	No-signal, no-load	1.85	2.05	2.25	V
Output pin voltage	V _{OUT}	No-signal, no-load		1.15		V
Voltage gain	G _V	Refer to measurement procedures	-0.5	0	6.5	dB
Frequency characteristic	f _c	Refer to measurement procedures	-1	0	+0.5	dB
Differential gain	DG	Refer to measurement procedures	-3	0	+3	%
Differential phase	DP	Refer to measurement procedures	-3	0	+3	deg
Y output dynamic range	V _{DY}	Refer to measurement procedures	2.6	2.9		V
C output dynamic range	V _{DC}	Refer to measurement procedures	2.0			V
C input impedance	Z _i			15		kΩ
Output impedance	Z _o			25		Ω

MITSUMI

Video Switch · 75Ω driver · Y/C mix MM1501

■ MM1512

Item	Symbol	Measurement conditions	Min.	Typ.	Max.	Unit
Consumption current	I _{CC}	Refer to measurement procedures		6.9	9.0	mA
Y input pin voltage	V _{YIN}	No-signal, no-load	1.95	2.15	2.35	V
C input pin voltage	V _{CIN}	No-signal, no-load	1.80	2.00	2.20	V
Output pin voltage	V _{OUT}	No-signal, no-load		1.10		V
Voltage gain	G _V	Refer to measurement procedures	5.5	6.0	6.5	dB
Frequency characteristic	f _c	Refer to measurement procedures	-1	0	+1	dB
Differential gain	DG	Refer to measurement procedures	-3	0	+3	%
Differential phase	DP	Refer to measurement procedures	-3	0	+3	deg
Y output dynamic range	V _{DY}	Refer to measurement procedures	2.6	2.9		V
C output dynamic range	V _{DC}	Refer to measurement procedures	2.0			V
C input impedance	Z _i			15		kΩ

Measurement Procedures

■ MM1501~MM1508

· Switch Status

Item	Symbol	Switch status		
		S1	S2	S3
Consumption current	I _{CC}	2	2	2
Voltage gain	G _V	1	2	2
		2	1	1
Frequency characteristic	f _c	1	2	2
		2	1	1
Differential gain	DG	1	2	2
		2	1	1
Differential phase	DP	1	2	2
		2	1	1

Item	Symbol	Switch status		
		S1	S2	S3
Total harmonic distortion ratio	THD	1	2	2
		2	1	1
Output dynamic range	V _D	1	2	2
		2	1	1
Output offset voltage	V _{OFF}	2	2	2
		2	2	1
Cross talk	C _T	1	2	1
		2	1	2
SW input voltage H	V _{IH}	2	2	1
SW input voltage L	V _{IL}			

·Measurement Procedures (MM1501 ~ MM1504)

Consumption current	I _{CC}	Connect a DC ammeter to V _{CC} pin and measure. Hereafter, short the ammeter to use.
Voltage gain	G _V	Input a 2.0V _{P-P} (1.0V _{P-P} for MM1502 and MM1504), 100kHz sine wave to SG1. If TP1 voltage is V1 and TP3 voltage is V2, find G _V using the following formula: $G_V = 20\text{LOG} (V_2/V_1) \text{ dB}$
Frequency characteristic	f _c	In the above G _V measurement, if TP3 voltage at 10MHz is V3, find f _c as follows: $f_c = 20\text{LOG} (V_3/V_2) \text{ dB}$
Differential gain	DG	Input a 2.0V _{P-P} (1.0V _{P-P} for MM1502 and MM1504) staircase to SG1 and measure differential gain at TP3. APL = 10 ~ 90%
Differential phase	DP	The same as for DG, but measure differential phase.
Total harmonic distortion ratio	THD	Input a 2.5V _{P-P} (1.25V _{P-P} for MM1502, MM1504), 1kHz sine wave to SG1, connect a distortion factor meter to TP3 and measure.
Output dynamic range	V _D	Input a 100kHz sine wave to SG1. Change the amplitude of the sine wave, and measure V _D , the maximum amplitude under THD 1%, at TP3.
Output offset voltage	V _{OFF}	Measure the DC voltage difference of each switch status at TP2.
Cross talk	C _T	VC1 = 2.1V and VC2 = 0.7V. Input a 2.0V _{P-P} , 4.43MHz sine wave to SG1, and operate SW3. If TP3 voltage when there is an output signal on the OUT pin is V4, and when there is no signal TP3 voltage is V5, then find C _T by the following formula: $C_T = 20\text{LOG} (V_5/V_4) \text{ dB}$
SW input voltage	V _I	Impress an optional DC voltage on TP5 and TP6. Gradually increase from VC1 = 0V. When TP6 voltage is output on TP2, TP4 voltage is V _{IH} . Gradually lower from VC1 = V _{CC} , and when TP5 voltage is output on TP2, TP4 voltage is V _{IL} .

· Measurement Procedures (MM1505 ~ MM1508)

Consumption current	I_{CC}	Connect a DC ammeter to V_{CC} pin and measure. Hereafter, short the ammeter to use.
Voltage gain	G_V	Input a 2.0V _{P-P} (1.0V _{P-P} for MM1506 and MM1508), 100kHz sine wave to SG1. If TP1 voltage is V_1 and TP3 voltage is V_2 , find G_V using the following formula: $G_V = 20\text{LOG} (V_2/V_1) \text{ dB}$
Frequency characteristic	f_c	In the above G_V measurement, if TP3 voltage at 7MHz is V_3 , find f_c as follows: $f_c = 20\text{LOG} (V_3/V_2) \text{ dB}$
Differential gain	DG	Input a 2.0V _{P-P} (1.0V _{P-P} for MM1506 and MM1508) staircase to SG1 and measure differential gain at TP3. $\text{APL} = 10 \sim 90\%$
Differential phase	DP	The same as for DG, but measure differential phase.
Output dynamic range	V_D	Input a 100kHz sine wave to SG1. Change the amplitude of the sine wave, and measure V_D , the maximum amplitude under THD 1%, at TP3.
Output offset voltage	V_{OFF}	Measure the DC voltage difference of each switch status at TP2.
Cross talk	C_T	$V_{C1} = 2.1\text{V}$ and $V_{C2} = 0.7\text{V}$. Input a 2.0V _{P-P} , 4.43MHz sine wave to SG1, and operate SW3. If TP3 voltage when there is an output signal on the OUT pin is V_4 , and when there is no signal TP3 voltage is V_5 , then find C_T by the following formula: $C_T = 20\text{LOG} (V_5/V_4) \text{ dB}$
SW input voltage	V_I	Impress an optional DC voltage on TP6 and TP7. Gradually increase from $V_{C1} = 0\text{V}$. When TP7 voltage is output on TP2, TP5 voltage is V_{IH} . Gradually lower from $V_{C1} = V_{CC}$, and when TP6 voltage is output on TP2, TP5 voltage is V_{IL} .

■ MM1511 ~ MM1512

· Switch Status

Item	Symbol	Switch status	
		S1	S2
Consumption current	I_{CC}	2	2
Voltage gain	G_V	1	2
		2	1
Frequency characteristic	f_c	1	2
		2	1

Item	Symbol	Switch status	
		S1	S2
Differential gain	DG	3	1
Differential phase	DP	3	1
Y output dynamic range	V_{DY}	2	1
C output dynamic range	V_{DC}	3	1

· Measurement Procedures

Consumption current	I_{CC1}	Connect a DC ammeter to the V_{CC} pin and measure. Hereafter, short the ammeter to use.
Voltage gain	G_V	Input a 2.0V _{P-P} (1.0V _{P-P} for MM1512), 100kHz sine wave to SG1. If TP1 voltage is V_1 and TP2 voltage is V_2 , find G_V by the following formula: $G_V = 20\text{LOG} (V_2/V_1) \text{ dB}$
Frequency characteristic	f_c	In the above G_V measurement, if TP2 voltage at 10MHz (7MHz for MM1512) is V_3 , find f_c by the following formula. $f_c = 20\text{LOG} (V_3/V_2) \text{ dB}$
Differential gain	DG	Input a 2.0V _{P-P} (1.0V _{P-P} for MM1512) to SG1, input a chroma signal to SG2, and measure differential gain at TP2. $\text{APL} = 10 \sim 90\%$
Differential phase	DP	The same as for DG, but measure differential phase.
Y output dynamic range	V_{DY}	Input a 100kHz sine wave to SG1. Measure V_{DY} , the maximum amplitude under THD 1%, at TP2.
C output dynamic range	V_{DC}	Input an APL 50% luminance signal to SG1 and input a chroma signal to SG2. Change the chroma signal amplitude and measure V_{DC} , the maximum amplitude where there is no waveform distortion at TP2.

TSH95**HIGH SPEED LOW POWER QUAD OPERATIONAL AMPLIFIER WITH DUAL **STANDBY** POSITION**

- **2 SEPARATE STANDBY** : REDUCED CONSUMPTION AND HIGH IMPEDANCE OUTPUTS
- LOW SUPPLY CURRENT : 4.5mA
- HIGH SPEED : 150MHz - 110V/ μ s
- UNITY GAIN STABILITY
- LOW OFFSET VOLTAGE : 4mV
- LOW NOISE 4.2 nV/ \sqrt Hz
- LOW COST
- SPECIFIED FOR **600 Ω** AND **150 Ω** LOADS
- HIGH VIDEO PERFORMANCES :
Differential Gain : 0.03%
Differential Phase : 0.07°
Gain Flatness : 6MHz, 0.1dB max. @ 10dB gain
- HIGH AUDIO PERFORMANCES
- ESD TOLERANCE : 2kV

DESCRIPTION

The TSH95 is a quad low power high frequency op-amp, designated for high quality video processing. The device offers an excellent speed consumption ratio with 4.5mA per amplifier for 150MHz bandwidth.

High slew rate and low noise make it also suitable for high quality audio applications.

The TSH95 offers 2 separate complementary **STANDBY** pins :

- STANDBY 1 acting on both n° 1 & 2 operators
- STANDBY 2 acting on both n° 3 & 4 operators

They reduce the consumption of the corresponding operators and put the output in a high impedance state.

ORDER CODE

Part Number	Temperature Range	Package
		D
TSH95I	-40°C, +125°C	•

D = Small Outline Package (SO) - also available in Tape & Reel (DT)

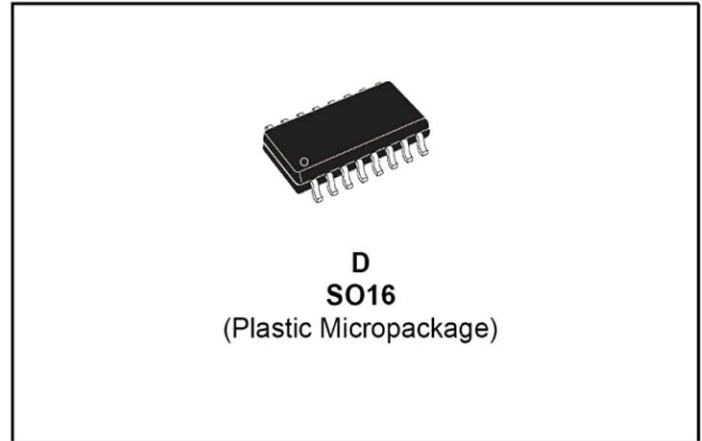
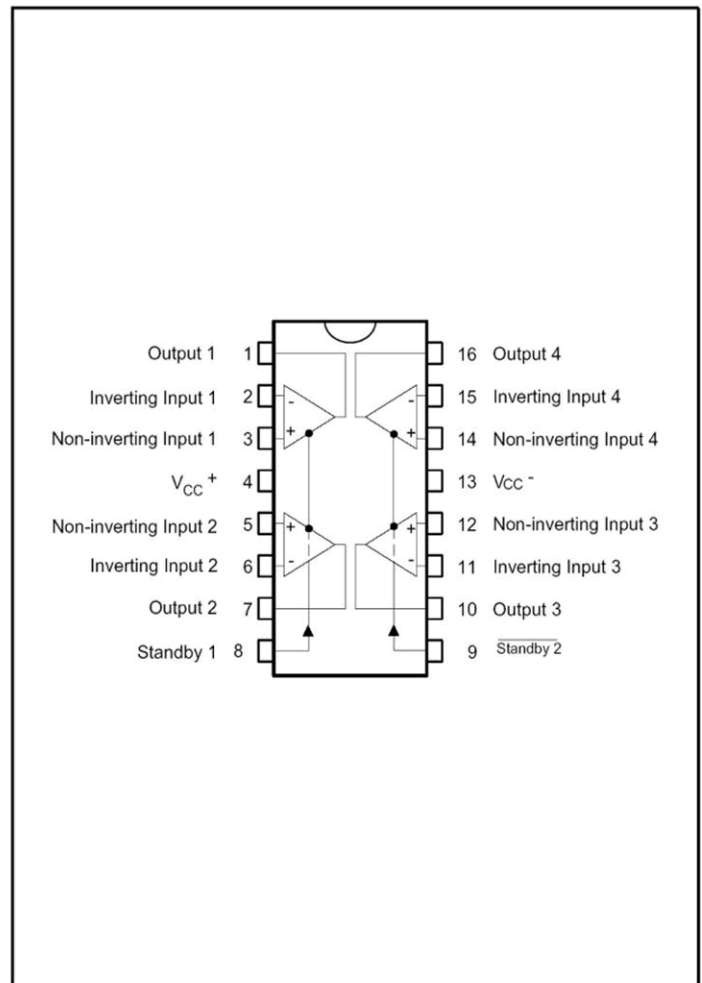
**PIN CONNECTIONS (top view)**



NJU7311A

ANALOG FUNCTION SWITCH

■ GENERAL DESCRIPTION

The NJU7311A is a hexad 2-channel and dual 1-channel analog function switch, especially suitable for input selector of audio equipments.

The high break down voltage analog switch controlled by 14-bit serial data based on logic operating voltage (5V) can ON and OFF of $\pm 15V$ signal.

The analog switch is realized superior linearity of on-resistance in all voltage range, low distortion and wide dynamic range.

Furthermore, the both of single and dual power supply application provides easy designing.

■ PACKAGE OUTLINE

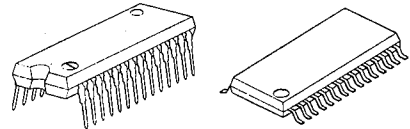

NJU7311AL

NJU7311AM

6

■ FEATURES

- Analog switch: hexad 2 channel and dual 1 channel.
- High Break Down Voltage $\pm 15V$.
- Low Distortion ----- THD: 0.002% (typ).
- Superior Linearity of ON Resistance.
- Serial Data Control.
- Package Outline SDIP 28 / DMP 30
- C-MOS Technology

■ PIN CONFIGURATION

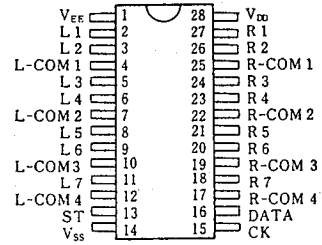

■ BLOCK DIAGRAM

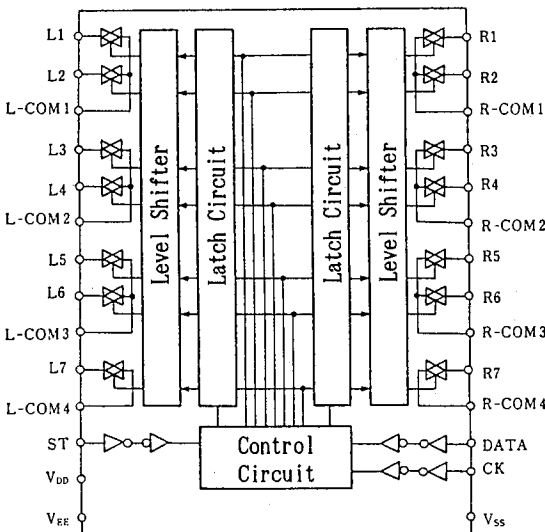

NJU7311AL

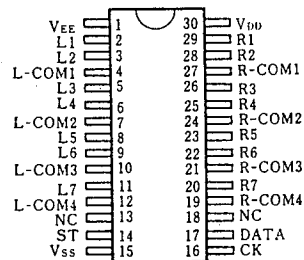

NJU7311AM



■ TERMINALS DESCRIPTION

No.		SYMBOL	FUNCTIONS	No.		SYMBOL	FUNCTIONS
DIP	DMP			DIP	DMP		
1	1	V _{EE}	Negative Voltage Supply	15	16	CK	Clock input
2	2	L1	Analog switch input/output	16	17	DATA	Data input
3	3	L2		17	19	R-COM4	R7 Common
4	4	L-COM1	L1, L2 Common	18	20	R7	Analog switch input/output
5	5	L3	Analog switch input/output	19	21	R-COM3	R5, R6 Common
6	6	L4		20	22	R6	Analog switch input/output
7	7	L-COM2	L3, L4 Common	21	23	R5	
8	8	L5	Analog switch input/output	22	24	R-COM2	R3, R4 Common
9	9	L6		23	25	R4	Analog switch input/output
10	10	L-COM3	L5, L6 Common	24	26	R3	
11	11	L7	Analog switch input/output	25	27	R-COM1	R1, R2 Common
12	12	L-COM4		L7 Common	26	28	R2
13	14	ST	Chip enable	27	29	R1	
14	15	V _{SS}	GND	28	30	V _{DD}	Positive voltage supply

■ FUNCTIONAL DESCRIPTION

(1) Timing of DATA, CK, ST

The Serial Input Data is input to internal shift register sequentially synchronized by clock signal rising edge input from CK terminal (100 kHz max.).

The Serial Input Data in the shift register is transferred to latch circuit and renew by synchronized rising edge of Chip enable signal input from ST terminal.

(Timing Chart)

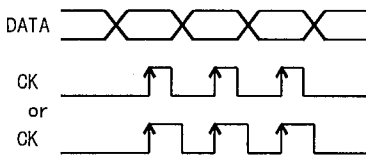

(Detailed Timing)

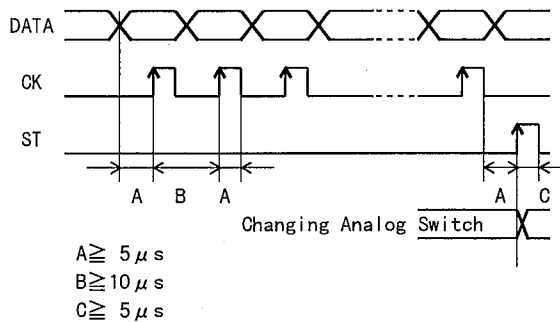

(2) Data Format

The 14-bit serial data strings format from MSB to LSB are 8-bit analog switch control data, 2-bit right and left channel selection data and 4-bit address data.

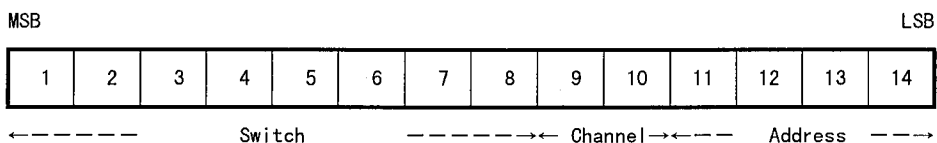



NJU7312A

ANALOG FUNCTION SWITCH

■ GENERAL DESCRIPTION

The NJU7312A is a quad 3-channel and dual 2-channel analog function switch, especially suitable for input selector of audio equipments.

The high break down voltage analog switch controlled by 14-bit serial data based on logic operating voltage (5V) can ON and OFF of $\pm 15V$ signal.

The analog switch is realized superior linearity of on-resistance in all voltage range, low distortion and wide dynamic range.

Furthermore, the both of single and dual power supply application provides easy designing.

■ PACKAGE OUTLINE

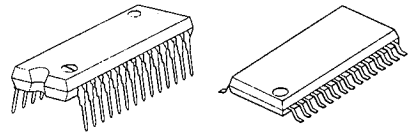

NJU7312AL

NJU7312AM

6

■ FEATURES

- Analog switch: quad 3 channel and dual 2 channel.
- High Break Down Voltage ----- $\pm 15V$.
- Low Distortion ----- THD: 0.002% (typ).
- Superior Linearity of ON Resistance.
- Serial Data Control.
- Package Outline SDIP 28 / DMP 30
- C-MOS Technology

■ PIN CONFIGURATION

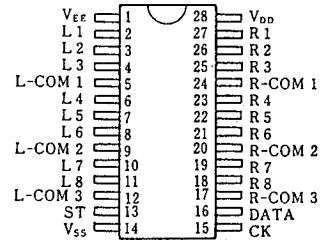

■ BLOCK DIAGRAM

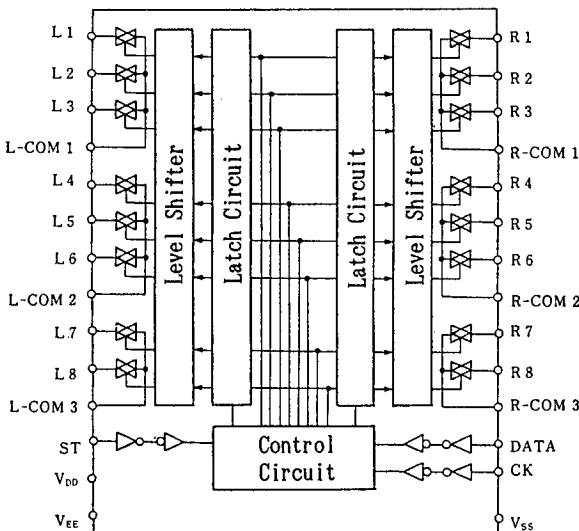

NJU7312AL

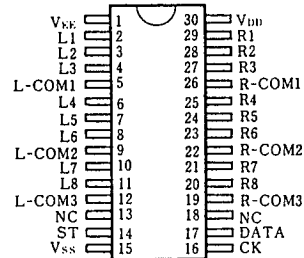

NJU7312AM



NJU7312A

■ TERMINALS DESCRIPTION

No.		SYMBOL	FUNCTIONS	No.		SYMBOL	FUNCTIONS
DIP	DMP			DIP	DMP		
1	1	V _{EE}	Negative Voltage Supply	15	16	CK	Clock input
2	2	L1	Analog switch input/output	16	17	DATA	Data input
3	3	L2		17	19	R-COM3	R7, L8 Common
4	4	L3		18	20	R8	Analog switch input/output
5	5	L-COM1		19	21	R7	
6	6	L4	Analog switch input/output	20	22	R-COM2	R4, R5, R6 Common
7	7	L5		21	23	R6	Analog switch input/output
8	8	L6		22	24	R5	
9	9	L-COM2		23	25	R4	
10	10	L7	Analog switch input/output	24	26	R-COM1	R1, R2, R3 Common
11	11	L8		25	27	R3	Analog switch input/output
12	12	L-COM3		26	28	R2	
13	14	ST		27	29	R1	
14	15	V _{SS}	GND	28	30	V _{DD}	Positive voltage supply

■ FUNCTIONAL DESCRIPTION

(1) Timing of DATA, CK, ST

The Serial Input Data is input to internal shift register sequentially synchronized by clock signal rising edge input from CK terminal(100 kHz max.).

The Serial Input Data in the shift register is transferred to latch circuit and renew by synchronized rising edge of Chip enable signal input from ST terminal.

(Timing Chart)

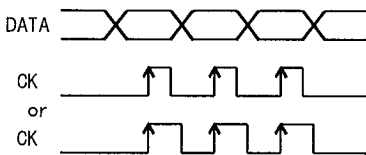

(Detailed Timing)

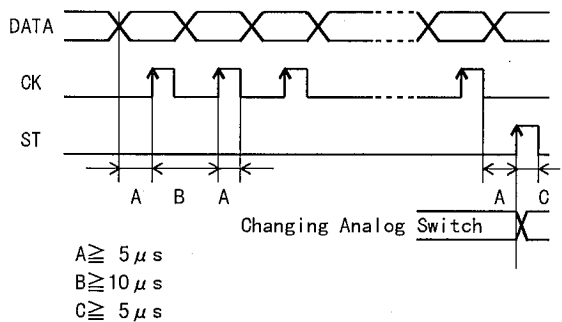

(2) Data Format

The 14-bit serial data strings format from MSB to LSB are 8-bit analog switch control data, 2-bit right and left channel selection data and 4-bit address data.

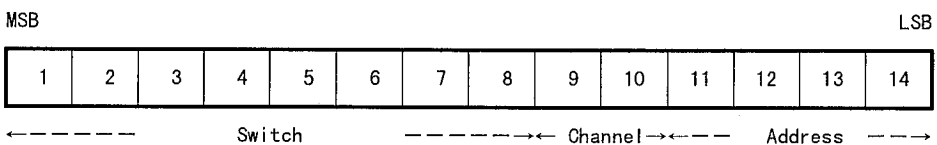



NJU201A

C-MOS QUAD SPST ANALOG SWITCH

■ GENERAL DESCRIPTION

The NJU201A is a quad break-before-make SPST analog switch protected up to 44V operating voltage.

All switches are controlled by TTL or C-MOS compatible input.

The low on-state resistance is about half compare with the NJU7301.

The NJU201A is functionally and pin-to-pin compatible with SILICONIX DG201A.

■ PACKAGE OUTLINE

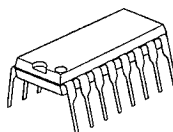

NJU201AD

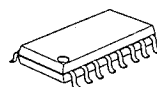

NJU201AM

■ FEATURES

- High Break Down Voltage -- 44V
- Low On-state Resistance
- Package Outline -- DIP/DMP 16
- C-MOS Technology

■ PIN CONFIGURATION

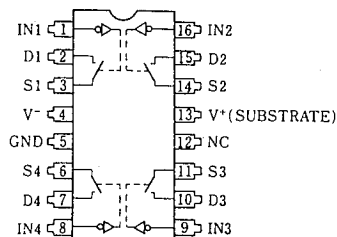

■ TRUTH TABLE

Logic (In)	Switch
0	ON
1	OFF

■ EQUIVALENT CIRCUIT

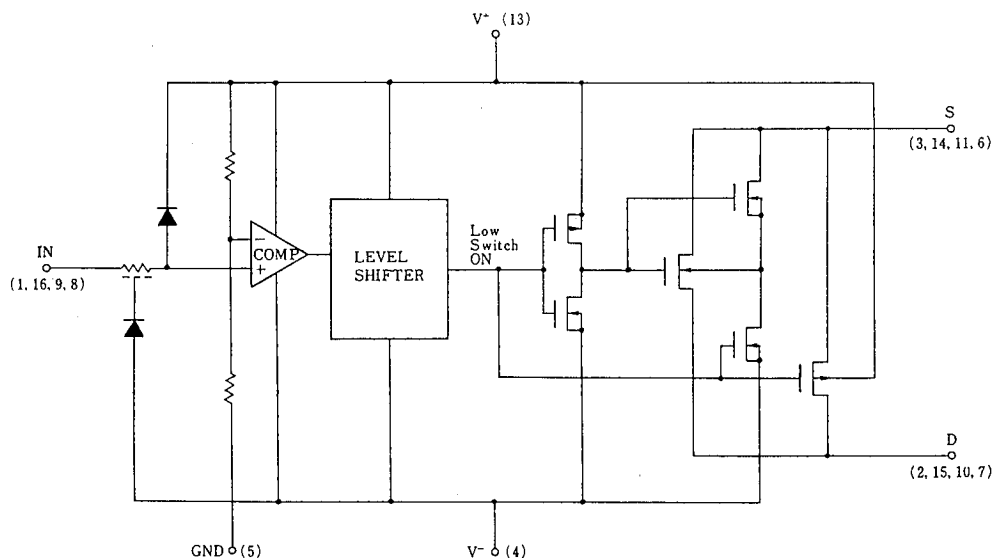

* Logic input threshold voltage V_{TH} is about $V^+ \times 0.128(V)$.
When the designing, enough margin is required.



M4A3-32-10VC-12VI

ispMACH™ 4A CPLD Family

High Performance E²CMOS®
In-System Programmable Logic

FEATURES

- ◆ High-performance, E²CMOS 3.3-V & 5-V CPLD families
- ◆ Flexible architecture for rapid logic designs
 - Excellent First-Time-Fit™ and refit feature
 - SpeedLocking™ performance for guaranteed fixed timing
 - Central, input and output switch matrices for 100% routability and 100% pin-out retention
- ◆ High speed
 - 5.0ns t_{PD} Commercial and 7.5ns t_{PD} Industrial
 - 182MHz f_{CNT}
- ◆ 32 to 512 macrocells; 32 to 768 registers
- ◆ 44 to 388 pins in PLCC, PQFP, TQFP, BGA, fpBGA and caBGA packages
- ◆ Flexible architecture for a wide range of design styles
 - D/T registers and latches
 - Synchronous or asynchronous mode
 - Dedicated input registers
 - Programmable polarity
 - Reset/ preset swapping
- ◆ Advanced capabilities for easy system integration
 - 3.3-V & 5-V JEDEC-compliant operations
 - JTAG (IEEE 1149.1) compliant for boundary scan testing
 - 3.3-V & 5-V JTAG in-system programming
 - PCI compliant (-5/-55/-6/-65/-7/-10/-12 speed grades)
 - Safe for mixed supply voltage system designs
 - Programmable pull-up or Bus-Friendly™ inputs and I/Os
 - Hot-socketing
 - Programmable security bit
 - Individual output slew rate control
- ◆ Advanced E²CMOS process provides high-performance, cost-effective solutions
- ◆ Supported by ispDesignEXPERT™ software for rapid logic development
 - Supports HDL design methodologies with results optimized for ispMACH 4A
 - Flexibility to adapt to user requirements
 - Software partnerships that ensure customer success
- ◆ Lattice and third-party hardware programming support
 - LatticePRO™ software for in-system programmability support on PCs and automated test equipment
 - Programming support on all major programmers including Data I/O, BP Microsystems, Advin, and System General

M4A3-32-10VC-12VI



44-PIN PLCC CONNECTION DIAGRAM (M4A(3,5)-32/32 AND M4A(3,5)-64/32)

Top View

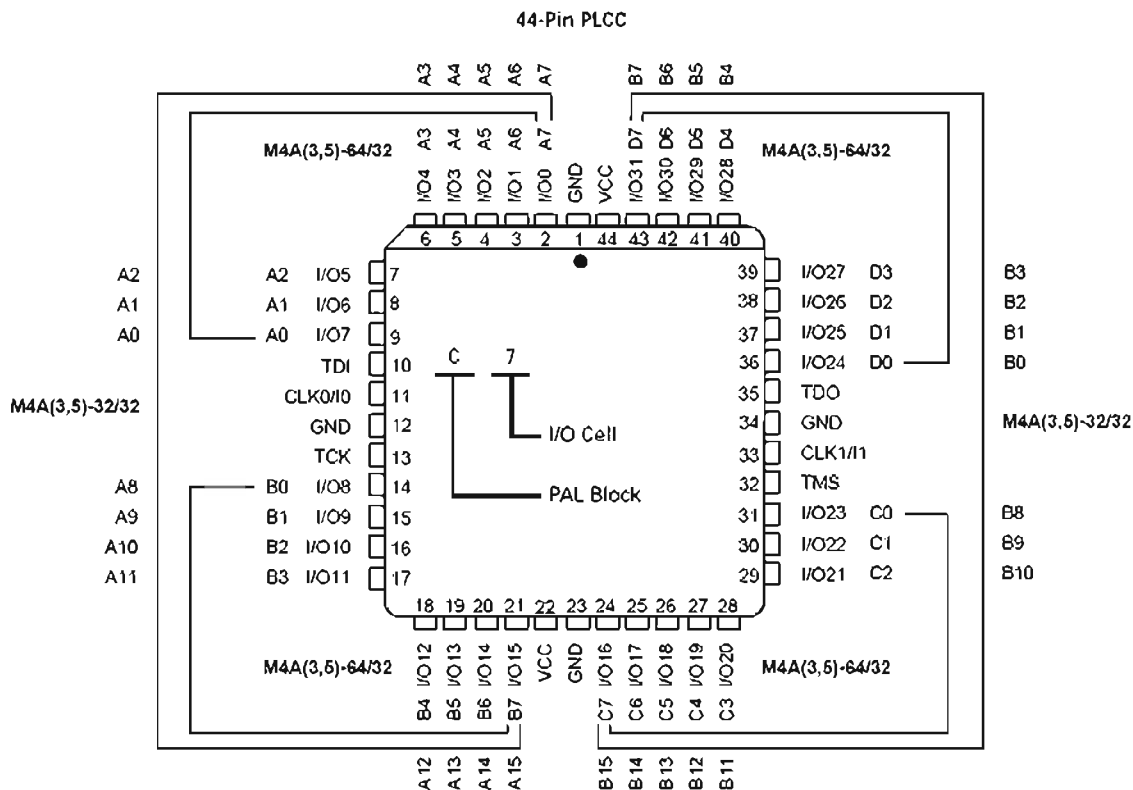

17466G-026

PIN DESIGNATIONS

- CLK/I = Clock or Input
- GND = Ground
- I/O = Input/Output
- VCC = Supply Voltage
- TDI = Test Data In
- TCK = Test Clock
- TMS = Test Mode Select
- TDO = Test Data Out



AK4114

High Feature 192kHz 24bit Digital Audio Interface Transceiver

GENERAL DESCRIPTION

The AK4114 is a digital audio transceiver supporting 192kHz, 24bits. The channel status decoder supports both consumer and professional modes. The AK4114 can automatically detect a Non-PCM bit stream. When combined with the multi channel codec (AK4527B or AK4529), the two chips provide a system solution for AC-3 applications. The dedicated pins or a serial μ P I/F can control the mode setting. The small package, 48pin LQFP saves the system space.

*AC-3 is a trademark of Dolby Laboratories.

FEATURES

- AES3, IEC60958, S/PDIF, EIAJ CP1201 Compatible
- Low jitter Analog PLL
- PLL Lock Range : 32kHz to 192kHz
- Clock Source: PLL or X'tal
- 8-channel Receiver input
- 2-channel Transmission output (Through output or DIT)
- Auxiliary digital input
- De-emphasis for 32kHz, 44.1kHz, 48kHz and 96kHz
- Detection Functions
 - Non-PCM Bit Stream Detection
 - DTS-CD Bit Stream Detection
 - Sampling Frequency Detection (32kHz, 44.1kHz, 48kHz, 88.2kHz, 96kHz, 176.4kHz, 192kHz)
 - Unlock & Parity Error Detection
 - Validity Flag Detection
- Up to 24bit Audio Data Format
- Audio I/F: Master or Slave Mode
- 40-bit Channel Status Buffer
- Burst Preamble bit Pc and Pd Buffer for Non-PCM bit stream
- Q-subcode Buffer for CD bit stream
- Serial μ P I/F
- Two Master Clock Outputs: 64fs/128fs/256fs/512fs
- Operating Voltage: 2.7 to 3.6V with 5V tolerance
- Small Package: 48pin LQFP
- Ta: -10 to 70°C

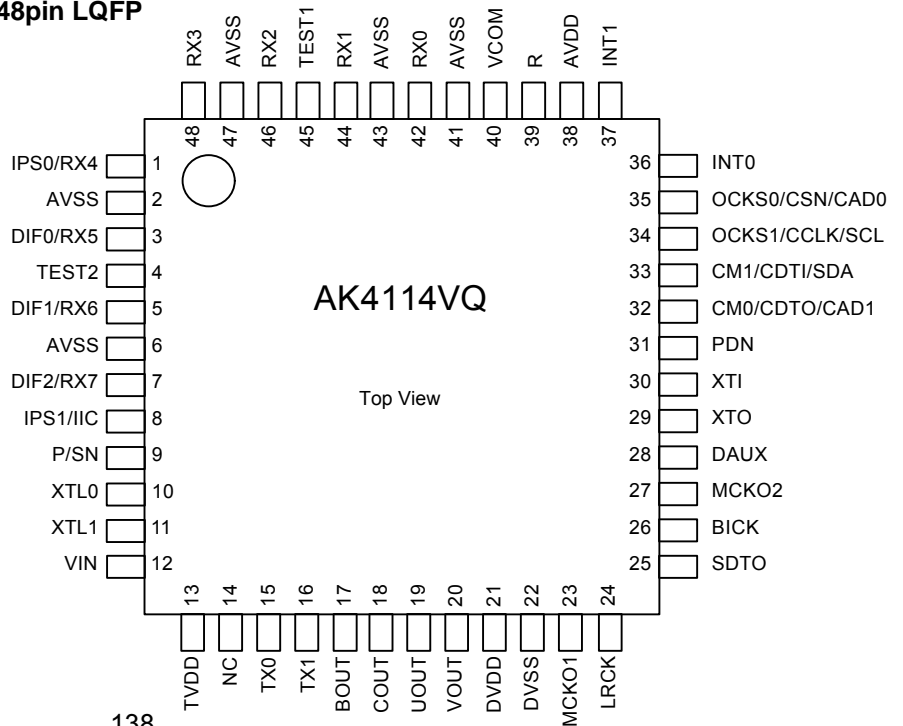

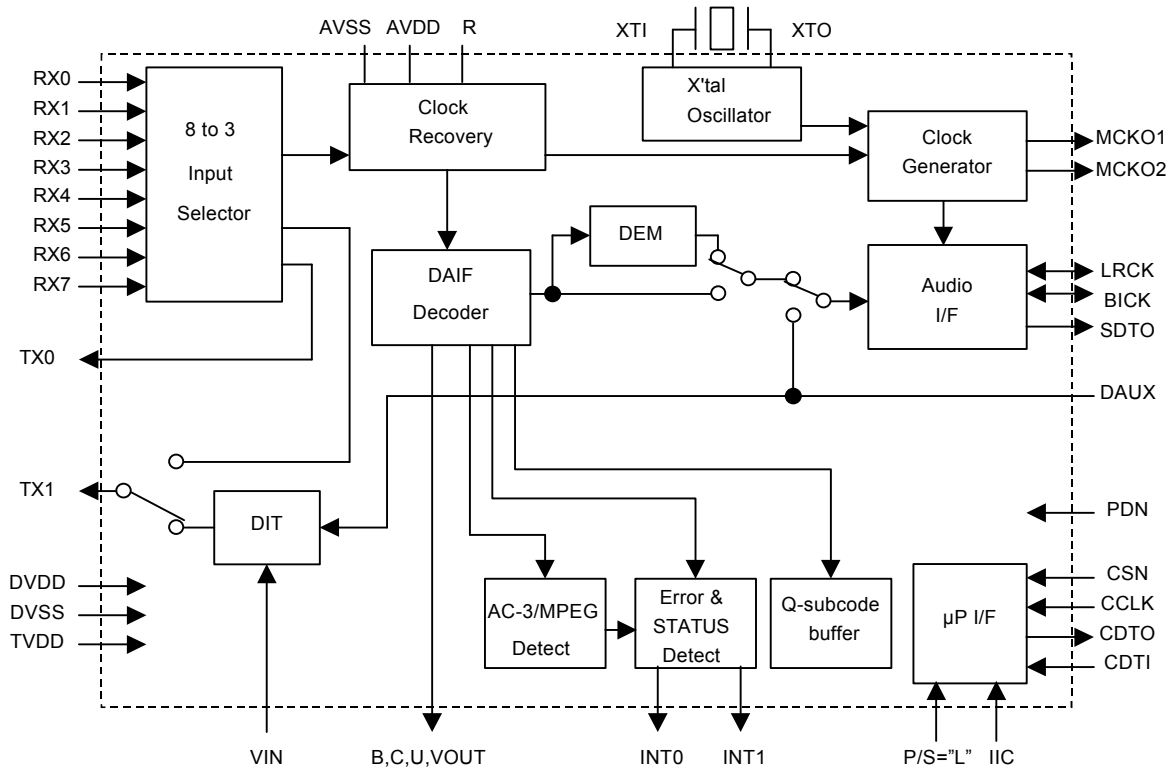

Serial Control Mode

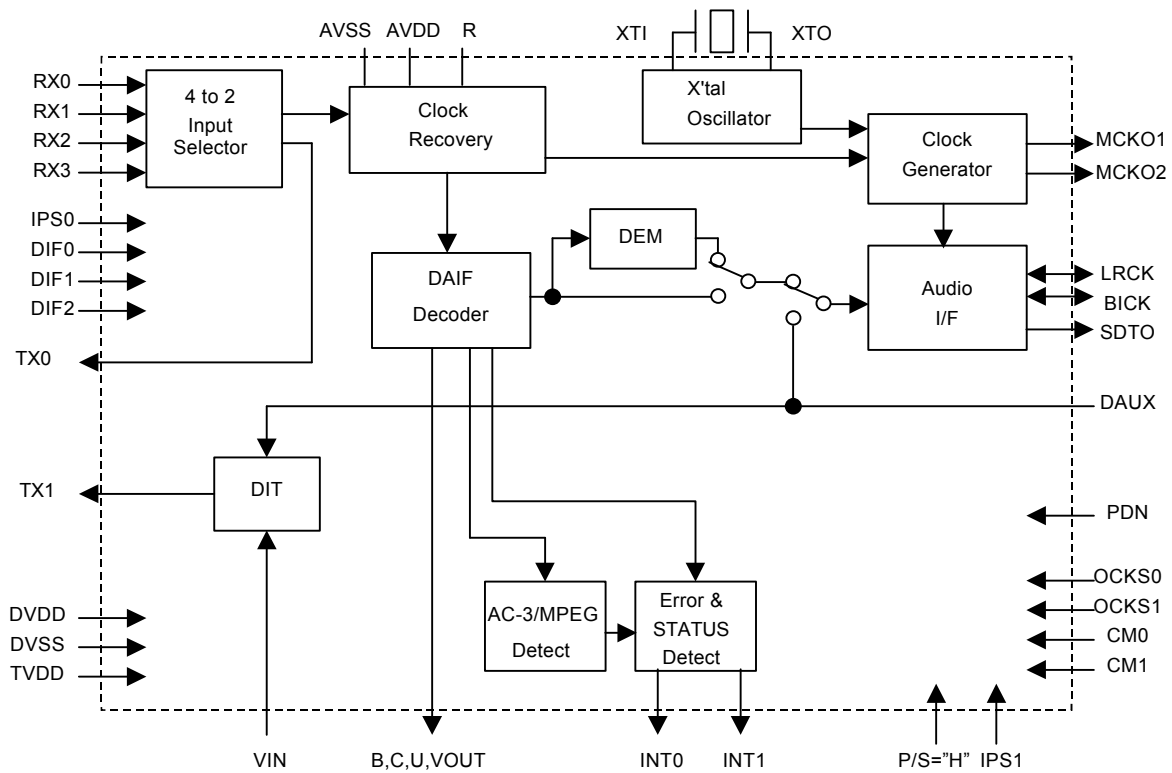

Parallel Control Mode

ASAHI KASEI

[AK4114]

PIN/FUNCTION			
No.	Pin Name	I/O	Function
1	IPS0	I	Input Channel Select 0 Pin in Parallel Mode
	RX4	I	Receiver Channel 4 Pin in Serial Mode (Internal biased pin)
2	NC(AVSS)	I	No Connect No internal bonding. This pin should be connected to AVSS.
3	DIF0	I	Audio Data Interface Format 0 Pin in Parallel Mode
	RX5	I	Receiver Channel 5 Pin in Serial Mode (Internal biased pin)
4	TEST2	I	TEST 2 pin This pin should be connect to AVSS.
5	DIF1	I	Audio Data Interface Format 1 Pin in Parallel Mode
	RX6	I	Receiver Channel 6 Pin in Serial Mode (Internal biased pin)
6	NC(AVSS)	I	No Connect No internal bonding. This pin should be connected to AVSS.
7	DIF2	I	Audio Data Interface Format 2 Pin in Parallel Mode
	RX7	I	Receiver Channel 7 Pin in Serial Mode (Internal biased pin)
8	IPS1	I	Input Channel Select 1 Pin in Parallel Mode
	IIC	I	IIC Select Pin in Serial Mode. “L”: 4-wire Serial, “H”: IIC
9	P/SN	I	Parallel/Serial Select Pin “L”: Serial Mode, “H”: Parallel Mode
10	XTL0	I	X'tal Frequency Select 0 Pin
11	XTL1	I	X'tal Frequency Select 1 Pin
12	VIN	I	V-bit Input Pin for Transmitter Output
13	TVDD	I	Input Buffer Power Supply Pin, 3.3V or 5V
14	NC	I	No Connect No internal bonding. This pin should be open or connected to DVSS.
15	TX0	O	Transmit Channel (Through Data) Output 0 Pin
16	TX1	O	When TX bit = “0”, Transmit Channel (Through Data) Output 1 Pin. When TX bit = “1”, Transmit Channel (DAUX Data) Output Pin (Default).
17	BOUT	O	Block-Start Output Pin for Receiver Input “H” during first 40 frames.
18	COUT	O	C-bit Output Pin for Receiver Input
19	UOUT	O	U-bit Output Pin for Receiver Input
20	VOUT	O	V-bit Output Pin for Receiver Input
21	DVDD	I	Digital Power Supply Pin, 3.3V
22	DVSS	I	Digital Ground Pin
23	MCKO1	O	Master Clock Output 1 Pin
24	LRCK	I/O	Channel Clock Pin
25	SDTO	O	Audio Serial Data Output Pin
26	BICK	I/O	Audio Serial Data Clock Pin
27	MCKO2	O	Master Clock Output 2 Pin
28	DAUX	I	Auxiliary Audio Data Input Pin
29	XTO	O	X'tal Output Pin
30	XTI	I	X'tal Input Pin

ASAHI KASEI

[AK4114]

PIN/FUNCTION (Continued)			
No.	Pin Name	I/O	Function
31	PDN	I	Power-Down Mode Pin When "L", the AK4114 is powered-down and reset.
32	CM0	I	Master Clock Operation Mode 0 Pin in Parallel Mode
	CDTO	O	Control Data Output Pin in Serial Mode, IIC= "L".
	CAD1	I	Chip Address 1 Pin in Serial Mode, IIC= "H".
33	CM1	I	Master Clock Operation Mode 1 Pin in Parallel Mode
	CDTI	I	Control Data Input Pin in Serial Mode, IIC= "L".
	SDA	I/O	Control Data Pin in Serial Mode, IIC= "H".
34	OCKS1	I	Output Clock Select 1 Pin in Parallel Mode
	CCLK	I	Control Data Clock Pin in Serial Mode, IIC= "L"
	SCL	I	Control Data Clock Pin in Serial Mode, IIC= "H"
35	OCKS0	I	Output Clock Select 0 Pin in Parallel Mode
	CSN	I	Chip Select Pin in Serial Mode, IIC="L".
	CAD0	I	Chip Address 0 Pin in Serial Mode, IIC= "H".
36	INT0	O	Interrupt 0 Pin
37	INT1	O	Interrupt 1 Pin
38	AVDD	I	Analog Power Supply Pin, 3.3V
39	R	-	External Resistor Pin 18k Ω +/-1% resistor should be connected to AVSS externally.
40	VCOM	-	Common Voltage Output Pin 0.47 μ F capacitor should be connected to AVSS externally.
41	AVSS	I	Analog Ground Pin
42	RX0	I	Receiver Channel 0 Pin (Internal biased pin) This channel is default in serial mode.
43	NC(AVSS)	I	No Connect No internal bonding. This pin should be connected to AVSS.
44	RX1	I	Receiver Channel 1 Pin (Internal biased pin)
45	TEST1	I	TEST 1 pin. This pin should be connected to AVSS.
46	RX2	I	Receiver Channel 2 Pin (Internal biased pin)
47	NC(AVSS)	I	No Connect No internal bonding. This pin should be connected to AVSS.
48	RX3	I	Receiver Channel 3 Pin (Internal biased pin)

Note 1. All input pins except internal biased pins should not be left floating.

MITSUBISHI MICROCOMPUTERS

M35012-XXXSP, M35013-XXXSP

SCREEN CHARACTER and PATTERN DISPLAY CONTROLLERS

DESCRIPTION

The M35012-XXXSP and M35013-XXXSP are TV screen display control IC which can be used to display information such as program schedules, the date and messages on the TV screen.

The differences among M35012-XXXSP and M35013-XXXSP are noted below.

The descriptions that follow describe the M35013-XXXSP unless otherwise noted.

Type name	M35012-XXXSP	M35013-XXXSP
Characters available	256	128
Data input	16 bits serial input	8 bits serial input
Exclusion function	Exclusion 1 and 2 function	Exclusion 1 function
CONT7F function	Normal/7F ₁₆ writing mode	Normal/7F ₁₆ writing mode

For M35013-001SP and M35012-001SP that are standard ROM version of M35013-XXXSP and M35012-XXXSP respectively, the I/O polarity of pin and the character pattern are also mentioned.

FEATURES

- Screen composition..... 24 columns X 10 lines
- Number of characters displayed..... 240 (Max.)
- Character composition 12 X 18 dot matrix
- Characters available
 - M35013-XXXSP..... 128 characters
 - M35012-XXXSP..... 256 characters
- Character sizes available ... 4 (horizontal) X 4 (vertical)
- Display locations available
 - Horizontal direction 62 locations
 - Vertical direction..... 64 locations
- Blinking Character units
 - Cycle : approximately 1 second, or approximately 0.5 seconds
 - Duty : 25%, 50%, or 75%
- Data Input
 - M35013-XXXSP..... By the 8-bit serial input function
 - M35012-XXXSP..... By the 16-bit serial input function
- Coloring
 - Background coloring (composite video signal)
- Blanking
 - Total blanking (14 X 18 dots)
 - Border size blanking
 - Character size blanking
- Synchronization signal
 - Composite synchronization signal generation (PAL, NTSC, M-PAL)
- Synchronized separation circuit..... Built-in
- 4 output ports (2 digital lines)
- Oscillation stop function
 - Be possible to stop the oscillation for display and for synchronized signal generation

PIN CONFIGURATION (TOP VIEW)

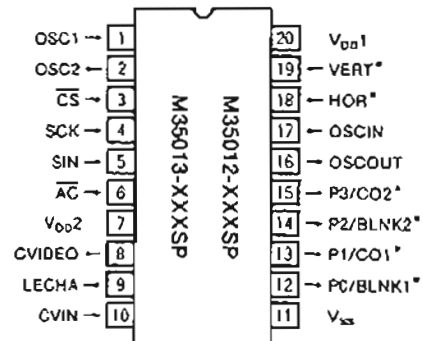

Outline 20P4B

Note : The pins remarked "*" are selectable the input or output polarity when the character ROM masked.

- Exclusion function
 - M35013-XXXSP..... 1
 - M35012-XXXSP..... 2
- Reversed character display function

APPLICATION

TV, VCR, Camcorder

MITSUBISHI MICROCOMPUTERS

M35012-XXXSP, M35013-XXXSP

SCREEN CHARACTER and PATTERN DISPLAY CONTROLLERS

BLOCK DIAGRAM

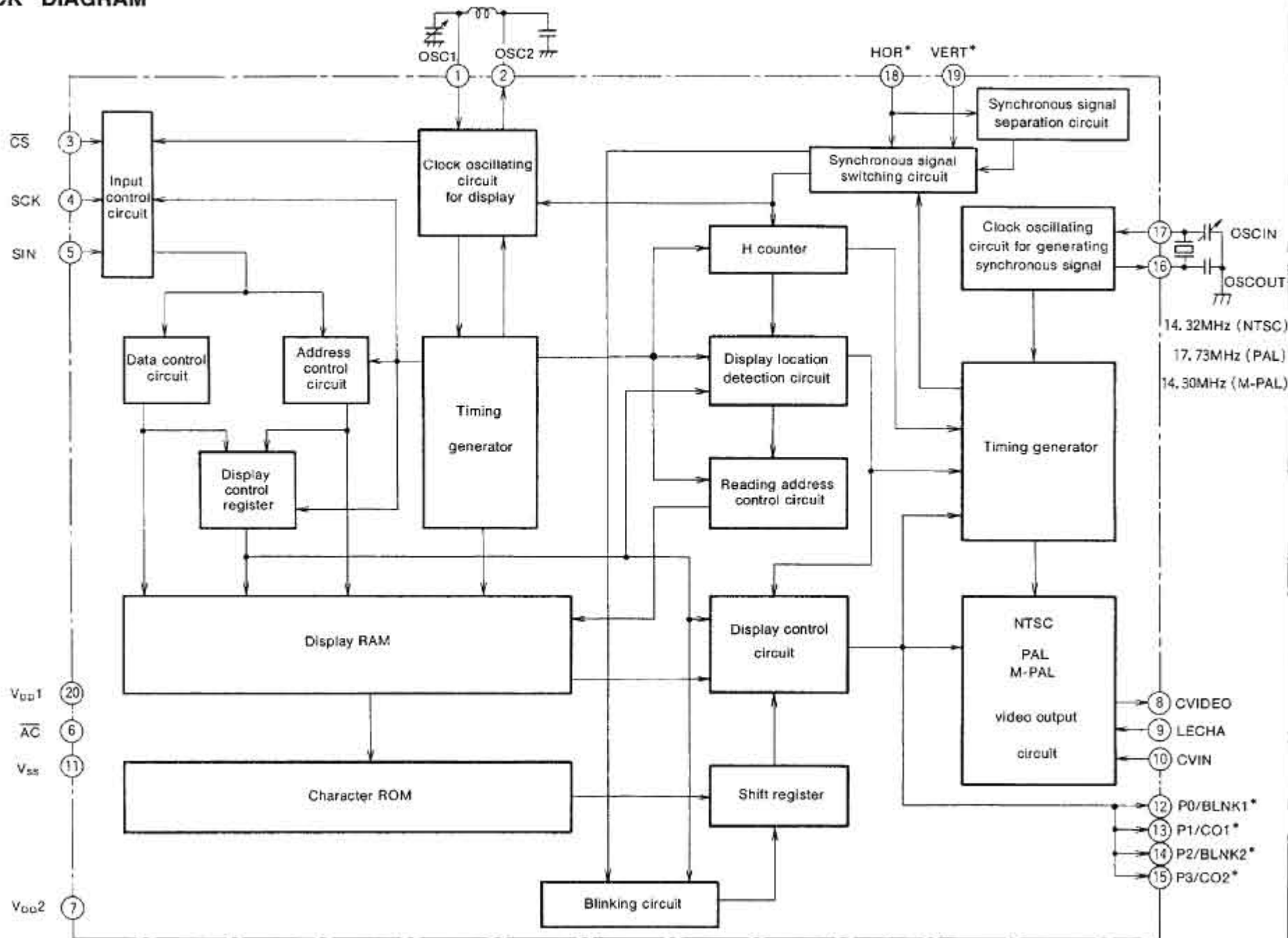

Note: The pins remarked "*" are selectable the input or output polarity when the character ROM masked.

MITSUBISHI MICROCOMPUTERS

M35012-XXXSP, M35013-XXXSP

SCREEN CHARACTER and PATTERN DISPLAY CONTROLLERS

PIN DESCRIPTION

Pin Number	Symbol	Pin name	Input /Output	Function
1	OSC1	Pins for attachment of external oscillator circuit	Input	These are the pins for attaching an external display oscillator circuit. The standard oscillation frequency is approximately 7MHz. This oscillation frequency determines the horizontal position of the display on the TV screen and the width of the characters.
2	OSC2		Output	
3	\overline{CS}	Chip select input	Input	This is the chip select pin, and when serial data transmission is being carried out, it goes to "L". Hysteresis input. Includes built-in pull-up resistor.
4	SCK	Serial clock input	Input	When \overline{CS} pin is "L", SIN serial data is taken in when SCK rises. Hysteresis input. Built-in pull-up resistor is included.
5	SIN	Serial data input	Input	This is the pin for serial input of data and addresses for the display control register and the display data memory. Hysteresis input. Includes built-in pull-up resistor.
6	\overline{AC}	Auto-clear input	Input	When "L", this pin resets the internal IC circuit. Hysteresis input. Includes built-in pull-up resistor.
7	V _{DD2}	Power pin	—	Please connect to +5V with the analog circuit power pin.
8	CVIDEO	Composite video signal output	Output	This is the output pin for composite video signals. It outputs 2V _{pp} composite video signals. In superimpose mode, character output etc. is superimposed on the external composite video signals from CVIN.
9	LECHA	Character level input	Input	This is the input pin which determines the "white" character color level in the composite video signal.
10	CVIN	Composite video signal input	Input	This is the input pin for external composite video signals. In superimpose mode, character output etc. is superimposed on these external composite video signals.
11	V _{SS}	Earthing pin	—	Please connect to GND using circuit earthing pin.
12	P0	Port P0 output	Output	This pin can be toggled between port pin output and BLNK1* (character background) signal output. Polarity can be selected when the character ROM is masked.
13	P1	Port P1 output	Output	This pin can be toggled between port pin output and CO1* (character) signal output. Polarity can be selected when the character ROM is masked.
14	P2	Port P2 output	Output	This pin can be toggled between port pin output and BLNK2* (character background) signal output. Polarity can be selected when the character ROM is masked.
15	P3	Port P3 output	Output	This pin can be toggled between port pin output and CO2* (character) signal output. Polarity can be selected when the character ROM is masked.
16	OSCOU	Pins for attachment of external oscillator circuit for synchronization signal generation	Output	These are the pins for attaching an external oscillator circuit for generating the synchronization signal. An oscillation of 14.32MHz is needed for NTSC, 17.73MHz is needed for PAL and 14.30MHz is needed for M-PAL.
17	OSCIN		Input	
18	HOR*	Horizontal synchronization signal input	Input	This pin inputs the horizontal synchronization signal. Hysteresis input. Polarity can be selected when the character ROM is masked.
19	VERT*	Vertical synchronization signal input	Input	This pin inputs the vertical synchronization signal. Hysteresis input. Polarity can be selected when the character ROM is masked.
20	V _{DD1}	Power pin	—	Please connect to +5V with the digital circuit power pin.

Note : The pins remarked "*" are selectable the input or output polarity when the character ROM masked.

NJM2068

LOW-NOISE DUAL OPERATIONAL AMPLIFIER

■ GENERAL DESCRIPTION

The NJM2068 is a high performance, low noise dual operational amplifier. This amplifier features popular pin-out, superior noise performance, and superior total harmonic distortion. This amplifier also features guaranteed noise performance with substantially higher gain-bandwidth product and slew rate, which far exceeds that of the 4558 type amplifier. The specially designed low noise input transistors allow the NJM2068 to be used in very low noise signal processing applications such as audio preamplifiers and servo error amplifier.

■ PACKAGE OUTLINE

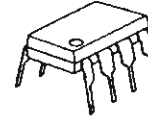

NJM2068D



NJM2068M



NJM2068V

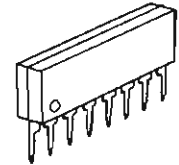

NJM2068L

■ FEATURES

- Operating Voltage ($\pm 4V \sim \pm 18V$)
- Low Total Harmonic Distortion (0.001% typ.)
- Low Noise Voltage (FLAT+JISA, $0.56\mu V$ typ.)
- High Slew Rate ($6V/\mu s$ typ.)
- Unity Gain Bandwidth (27MHz @ $f=10kHz$)
- Package Outline DIP8, DMP8, SIP8, SSOP8
- Bipolar Technology

■ PIN CONFIGURATION

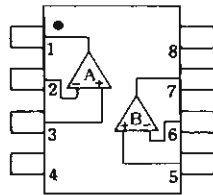

NJM2068D
NJM2068M
NJM2068V

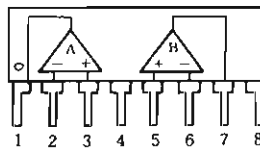

NJM2068L

- PIN FUNCTION**
- 1.A OUTPUT
 - 2.A -INPUT
 - 3.A +INPUT
 - 4.V⁻
 - 5.B +INPUT
 - 6.B -INPUT
 - 7.B OUTPUT
 - 8.V⁺

■ EQUIVALENT CIRCUIT (1/2 Shown)

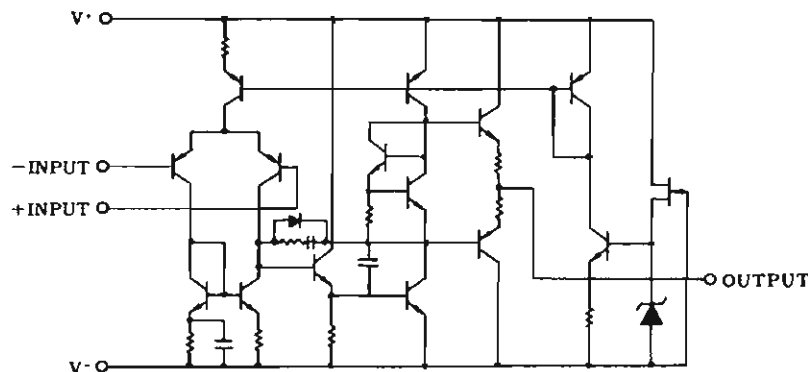

NJM2296

5-INPUT 3-OUTPUT VIDEO SW

GENERAL DESCRIPTION

The NJM2296 is a 5-input 3-output video switch. Its switches select one from five signals received from VTR, TV, TV GAME and others.

This IC is designed for audio items, such as AV amplifier and receivers, and others

PACKAGE OUTLINE

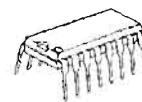

NJM2296D



NJM2296M

FEATURES

- 5-input 3-output
- Operating Voltage ± 4.0 to $\pm 6.5V$
- Operating Current $\pm 31mA$ typ. at $V_{cc}=\pm 5V$
- Crosstalk $-65dB$ typ.
- Internal 6dB Amplifier
- Internal 75Ω Driver
- Bipolar Technology
- Package Outline DIP16,DMP16

BLOCK DIAGRAM

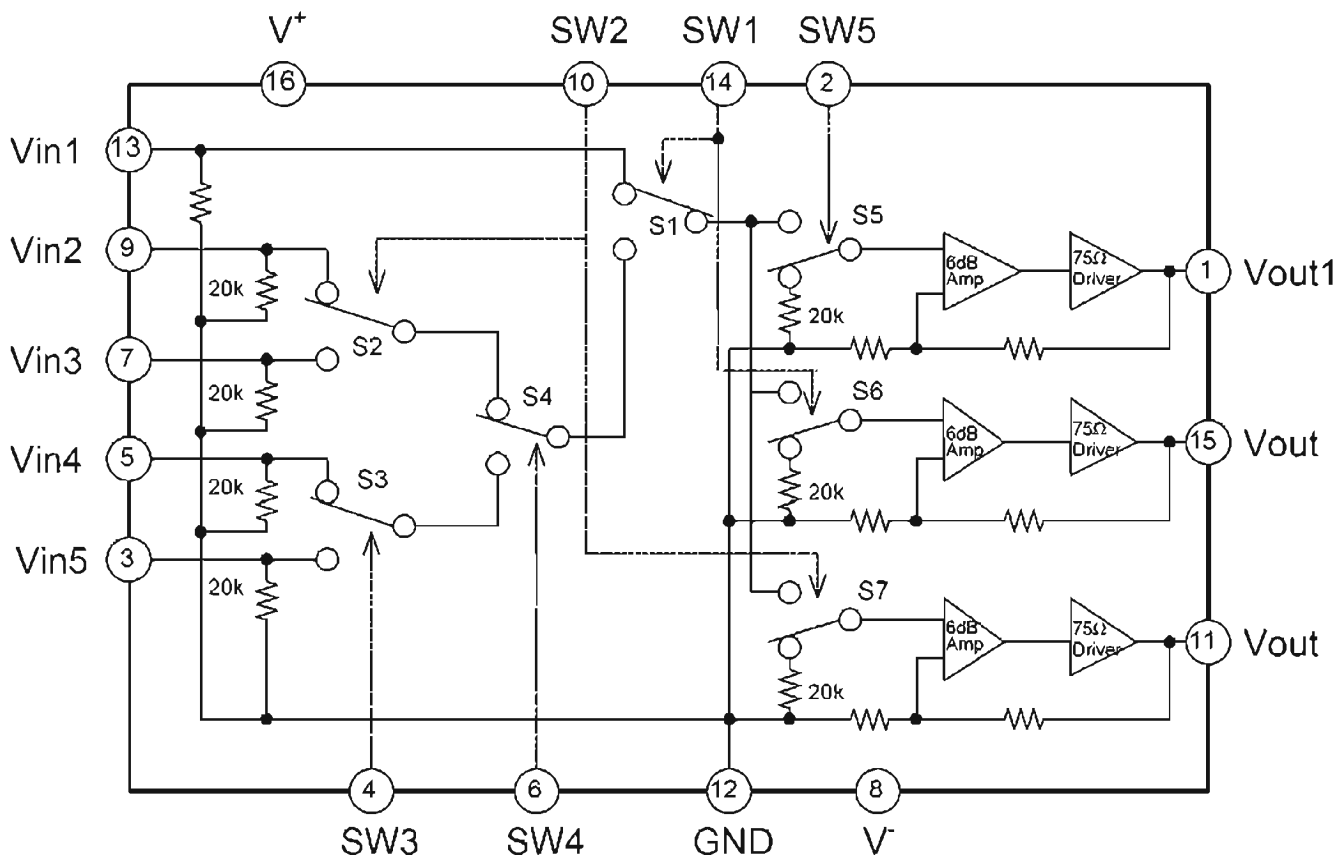



NJM5532

LOW-NOISE DUAL OPERATIONAL AMPLIFIER

■ GENERAL DESCRIPTION

The NJM5532 is a high performance dual low noise operational amplifier. Compared to the standard dual operational amplifiers, such as the NJM1458, it shows better noise performance, improved output drive capability, and considerably higher small-signal and power bandwidths.

This makes the device especially suitable for application in high quality and professional audio equipment, instrumentation, control circuits, and telephone channel amplifiers. The op amp is internally compensated for gains equal to one if very low noise is of prime importance, version be used which has guaranteed NJM5532DD it is recommended that the noise specifications.

■ PACKAGE OUTLINE



NJM5532D



NJM5532M

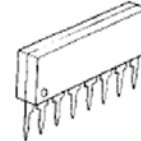

NJM5532L

■ FEATURES

- Operating Voltage ($\pm 3V \sim \pm 20V$)
- Small Signal Bandwidth (10MHz typ.)
- Output Drive Capability ($600\Omega, 10V_{rms}$ typ.)
- Input Noise Voltage ($5nV/\sqrt{Hz}$ typ.)
- Power Bandwidth (140kHz typ.)
- Slew Rate ($8V/\mu s$ typ.)
- Package Outline DIP8, DMP8, SIP8
- Bipolar Technology

■ PIN CONFIGURATION

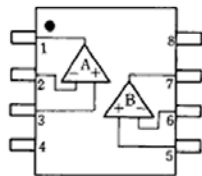

NJM5532D
NJM5532M

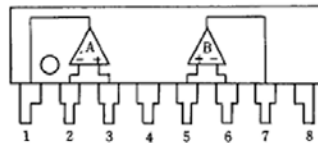

NJM5532L

PIN FUNCTION

- 1.A OUTPUT
- 2.A -INPUT
- 3.A +INPUT
- 4.V⁻
- 5.B +INPUT
- 6.B -INPUT
- 7.B OUTPUT
- 8.V⁺

■ EQUIVALENT CIRCUIT

(1/2 Shown)

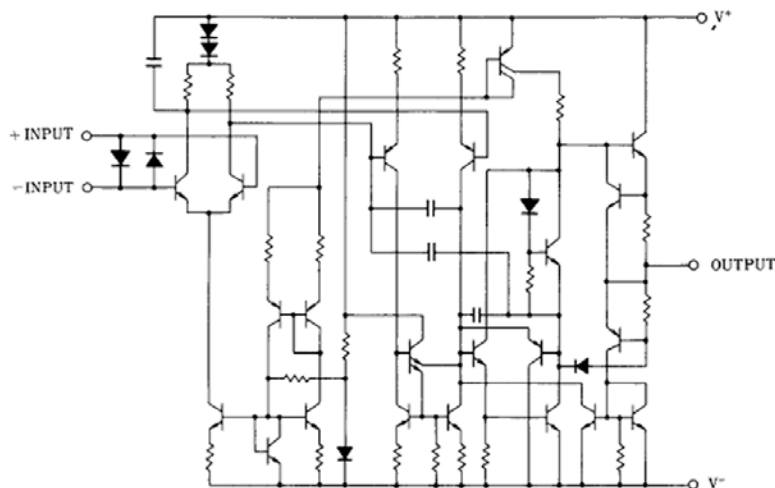



NJM2395/2396

LOW DROPOUT VOLTAGE REGULATOR WITH ON/OFF CONTROL

GENERAL DESCRIPTION

The NJM2396 is low dropout voltage regulator with ON/OFF control.

The output current is up to 1.5A and dropout voltage is 0.2V_{typ.} at $I_o=0.5A$.

The NJM2396 is suitable for power module, TV, Display, car stereo and low power applications.

PACKAGE OUTLINE

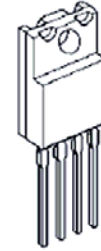

NJM2396F

FEATURE

- Low Dropout Voltage $\Delta V_{I,0}=0.2V$ typ. at $I_o=0.5A$
- Output Current $I_o(\text{max.})=1.5A$
- ON/OFF Control
- Internal Short Circuit Current Limit
- Internal Thermal Overload Protection
- Bipolar Technology
- Package Outline TO-220F-4

PIN CONFIGURATION

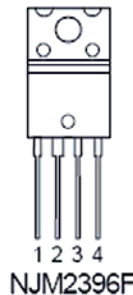

PIN FUNCTION

1. V_{IN}
2. V_{OUT}
3. GND
4. ON/OFF CONTROL

OUTPUT VOLTAGE RANK LIST

Device Name	V_{OUT}
NJM2396F33	3.3V
NJM2396F05	5.0V
NJM2396F63	6.3V
NJM2396F08	8.0V
NJM2396F83	8.3V
NJM2396F09	9.0V
NJM2396F12	12.0V

EQUIVALENT CIRCUIT

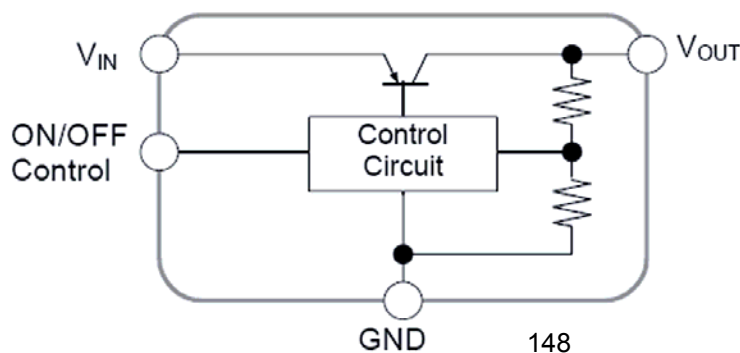



M54HCU04
M74HCU04

HEX INVERTER (SINGLE STAGE)

- HIGH SPEED
 $t_{PD} = 5 \text{ ns (TYP.) AT } V_{CC} = 5 \text{ V}$
- LOW POWER DISSIPATION
 $I_{CC} = 1 \mu\text{A (MAX.) AT } T_A = 25 \text{ }^\circ\text{C}$
- HIGH NOISE IMMUNITY
 $V_{NIH} = V_{NIL} = 10 \% V_{CC} \text{ (MIN.)}$
- OUTPUT DRIVE CAPABILITY
 10 LSTTL LOADS
- SYMMETRICAL OUTPUT IMPEDANCE
 $|I_{OH}| = I_{OL} = 4 \text{ mA (MIN.)}$
- BALANCED PROPAGATION DELAYS
 $t_{PLH} = t_{PHL}$
- WIDE OPERATING VOLTAGE RANGE
 $V_{CC} \text{ (OPR)} = 2 \text{ V TO } 6 \text{ V}$
- PIN AND FUNCTION COMPATIBLE WITH
 54/74LS04

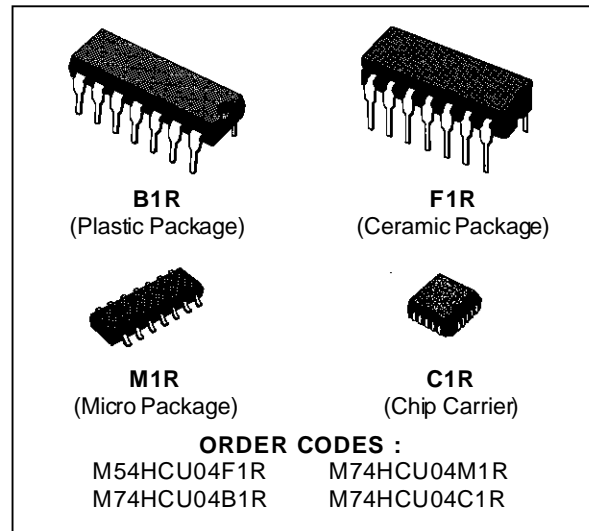

DESCRIPTION

The M54/74HCU04 is a high speed CMOS HEX INVERTER (SINGLE STAGE) fabricated in silicon gate C²MOS technology. It has the same high speed performance of LSTTL combined with true CMOS low power consumption.

As the intrnal circuit is composed of a single stage inverter, it can be used in crystal oscillator.

All inputs are equipped with circuits against static discharge and transient excess voltage.

INPUT AND OUTPUT EQUIVALENT CIRCUIT

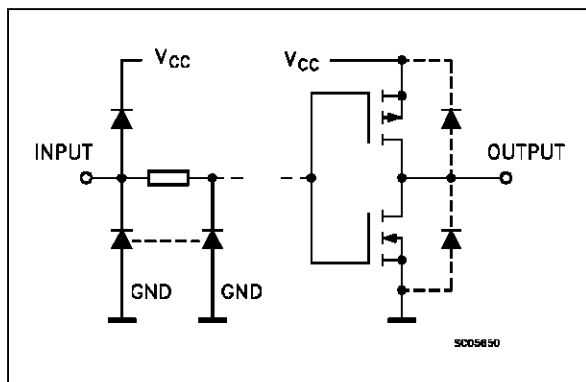

PIN CONNECTIONS (top view)

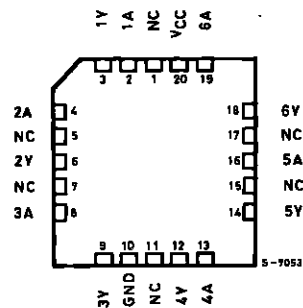
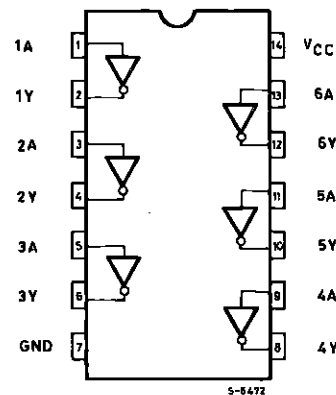

NC =
No Internal
Connection

TC9273N

CMOS Digital IC

BLOCK DIAGRAM

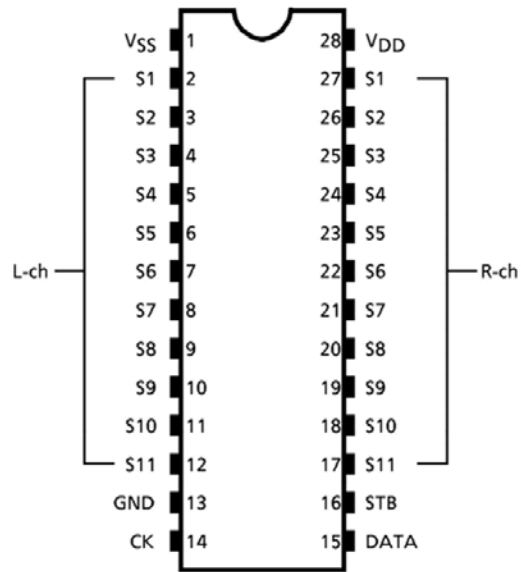
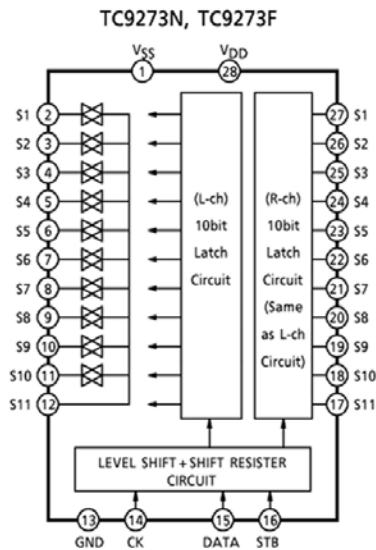

PIN FUNCTION (Left channel / right channel)

PIN No.			SYMBOL	PIN NAME	FUNCTION AND OPERATION	NOTE
TC9273N / F	TC9274N	TC9274F				
1	1	40	V _{SS}	Negative power supply pin	Dual power supply $V_{DD} = 8.0 \sim 17V$ $GND = 0V$ $V_{SS} = -8.0 \sim -17V$	—
13	20	16	GND	Digital ground pin		
28	42	38	V _{DD}	Positive power supply pin		
2 / 27	2 / 41	41 / 37	S1	Input / output pins	Analog switch input pins. × : Aluminum mask switch. • : Open or closed can be specified. Connection for right and left channels can be different.	—
3 / 26	3 / 40	42 / 36	S2			
4 / 25	4 / 39	43 / 35	S3			
5 / 24	5 / 38	44 / 34	S4			
6 / 23	6 / 37	1 / 33	S5			
7 / 22	7 / 36	2 / 32	S6			
8 / 21	8 / 35	3 / 31	S7			
9 / 20	9 / 34	4 / 30	S8			
10 / 19	10 / 33	5 / 29	S9			
11 / 18	11 / 32	6 / 28	S10			
—	13 / 30	8 / 26	S12			
—	14 / 29	9 / 25	S13			
—	15 / 28	10 / 24	S14			
—	16 / 27	11 / 23	S15			
—	17 / 26	12 / 22	S16			
—	18 / 25	13 / 21	S17			
—	19 / 24	14 / 20	S18			
—	—	17 / 39	NC			
14	21	16	CK	Clock input pin	Clock input for data transfer	Low threshold value input pins
15	22	18	DATA	Data input pin	Serial data input for setting switches	
16	23	19	STB	Strobe input pin	Strobe input for data writing	

TOSHIBA**TC9482N/F**

TOSHIBA CMOS DIGITAL INTEGRATED CIRCUIT SILICON MONOLITHIC

TC9482N, TC9482F

SYSTEM ELECTRONIC VOLUME CONTROL

The TC9482N and TC9482F are six-channel electronic volume control ICs developed for Hi-Fi audio equipment. Since all six channels can be individually controlled, the devices are optimum for audio equipment with multiple outputs.

FEATURES

- Sound volume can be controlled in 97 steps from 0 to -95dB or up to an infinite level in 1dB increments.
- Incorporating six channels of volume control circuits, the device allows independent volume control.
- Can operate with a single or dual power supplies.
- Can control up to 4 chips on the same bus by using chip select input.
- Built-in interface for 5-V microcomputers.
- Thanks to its polysilicon resistor, the device allows you to configure a low-distortion, high-performance volume control system.
- Two packages supported: 28-pin shrink DIP and 28-pin flat package.

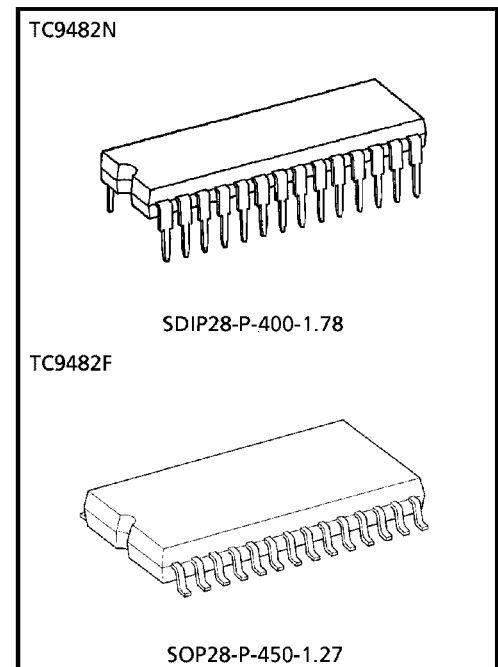

Weight

SDIP28-P-400-1.78 : 2.2 g (Typ.)
 SOP28-P-450-1.27 : 0.8 g (Typ.)

PIN CONNECTIONS

VSS	1	28	VDD
NC	2	27	TEST
L-OUTA	3	26	R-OUTA
L-INA	4	25	R-INA
L-A-GNDA	5	24	R-A-GNDA
L-OUTB	6	23	R-OUTB
L-INB	7	22	R-INB
L-A-GNDB	8	21	R-A-GNDB
L-OUTC	9	20	R-OUTC
L-INC	10	19	R-INC
L-A-GNDC	11	18	R-A-GNDC
CS1	12	17	CS2
GND	13	16	STB
CK	14	15	DATA

BLOCK DIAGRAM

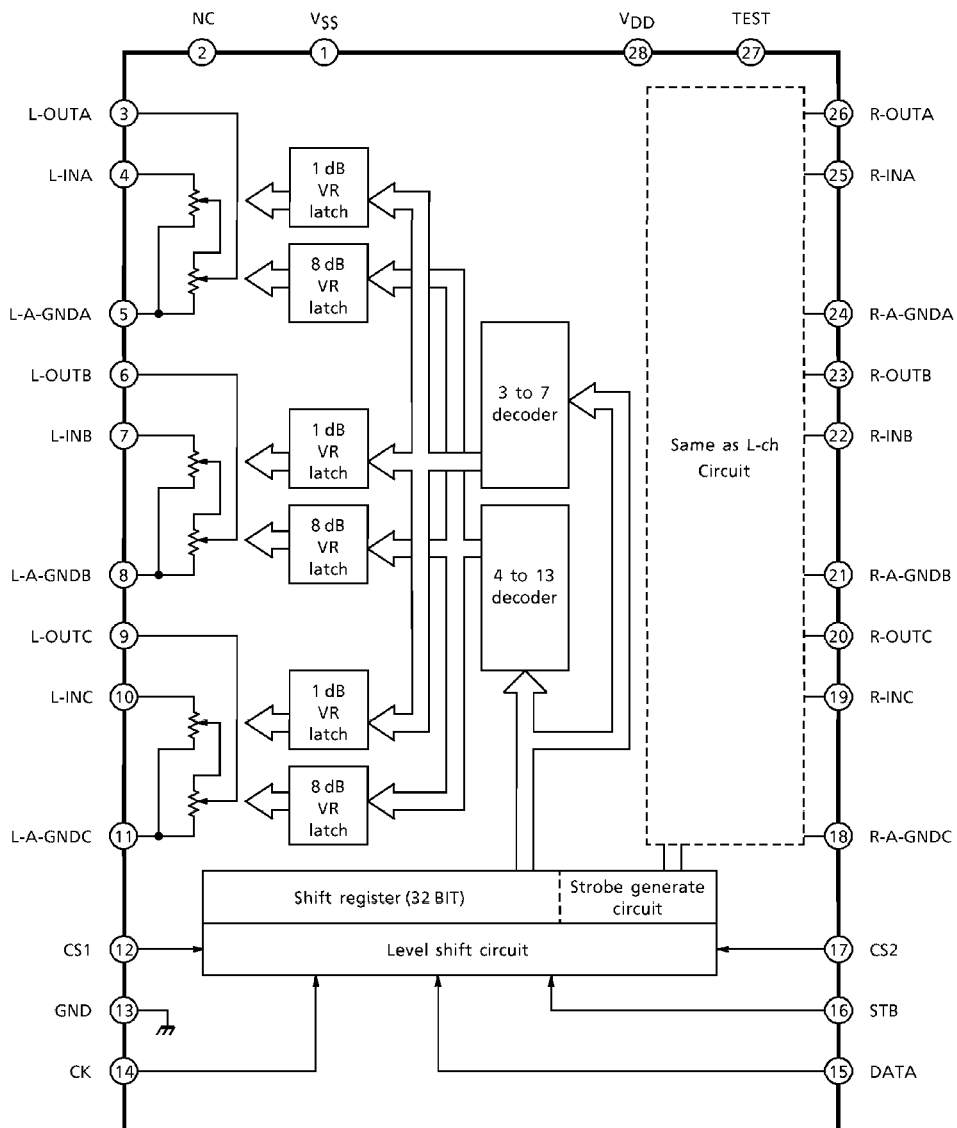

TOSHIBA**TC9459N/F**

TOSHIBA CMOS DIGITAL INTEGRATED CIRCUIT SILICON MONOLITHIC

TC9459N, TC9459F

ELECTRONIC VOLUME CONTROL

The TC9459N, TC9459F are electronic volume control ICs developed for use in home stereos and other audio equipment.

Using serial data input from external sources, it controls the sound volume, balance and loudness circuits.

FEATURES

- Sound volume can be controlled in 91 steps from 0 to -89dB or up to an infinite level in 1dB increments.
- Incorporating two channels of volume control circuits, the device allows independent volume control : therefore, it also provides the balancing function.
- A loudness circuit (20dB tap) is built in.
- Can operate with a single or dual power supplies.
- Can control up to 4 chips on the same bus by using chip select input.
- Thanks to its polysilicon resistor, the device allows you to configure a low-distortion, high-performance volume control system.

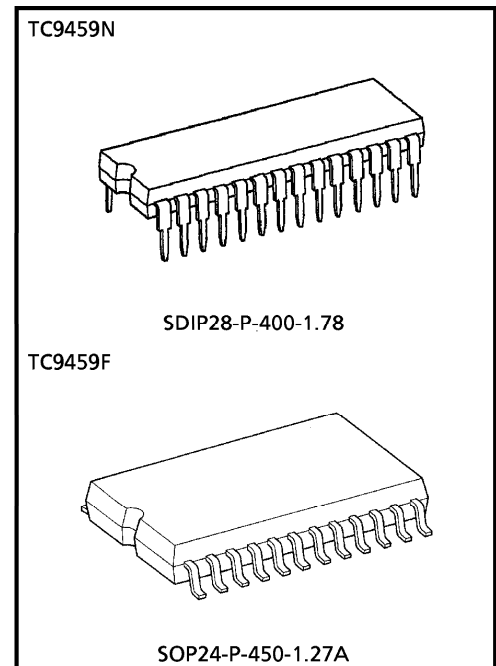

Weight

SDIP28-P-400-1.78 : 2.2g (Typ.)
 SOP24-P-450-1.27A : 0.44g (Typ.)

PIN CONNECTIONS

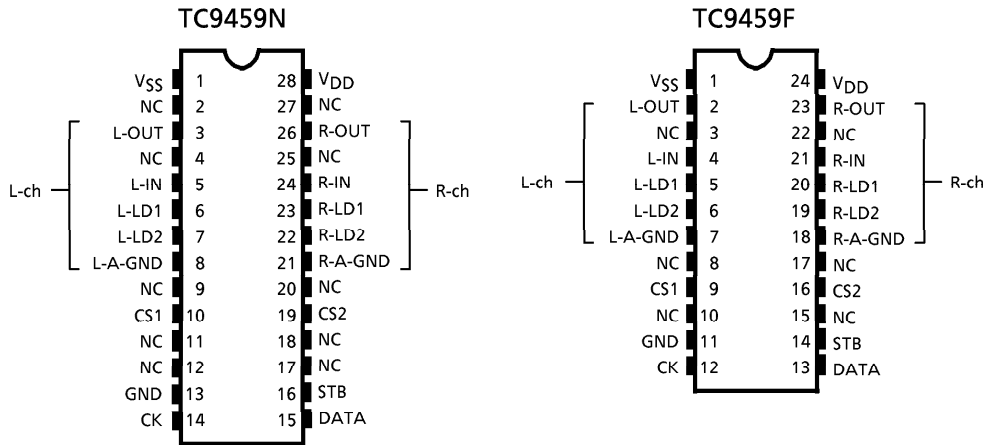

BLOCK DIAGRAM (TC9459N)

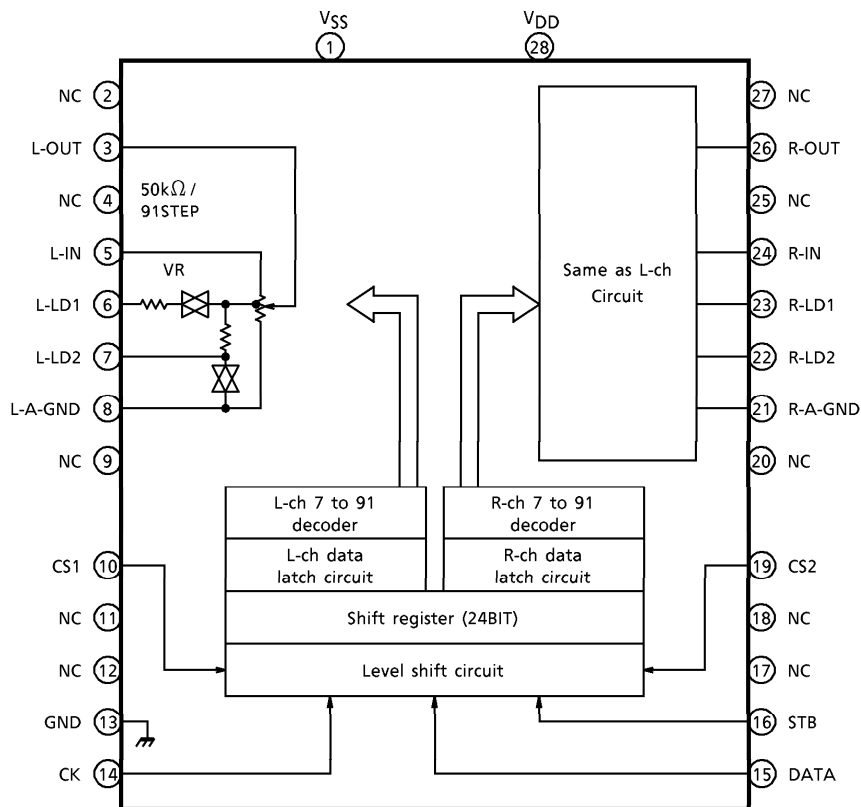

TOSHIBA**TC9459N/F****PIN DESCRIPTION**

Numeral in () means the pin No. of TC9459F.

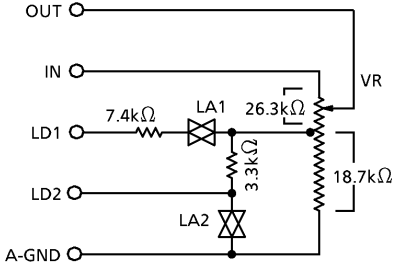
PIN No.	SYMBOL	PIN NAME	FUNCTION	REMARK										
1 (1)	V _{SS}	Negative power supply pin	When using dual power supplies $V_{DD} = 6.0 \sim 17V$ $GND = 0V$ $V_{SS} = -6.0 \sim -17V$ When using a single power supply $V_{DD} = 6.0 \sim 18V$ $GND = V_{SS} = 0V$	—										
28 (24)	V _{DD}	Positive power supply pin												
13 (11)	GND	Digital GND pin												
3 (2)	L-OUT	Volume output pin	• Volume circuit 	—										
26 (23)	R-OUT													
5 (4)	L-IN	Volume input pin												
24 (21)	R-IN													
6 (5)	L-LD1	Loudness tap output pin			<table border="1" data-bbox="933 1019 1236 1153"> <thead> <tr> <th></th> <th>LA1</th> <th>LA2</th> </tr> </thead> <tbody> <tr> <td>LOUDNESS "ON"</td> <td>ON</td> <td>OFF</td> </tr> <tr> <td>LOUDNESS "OFF"</td> <td>OFF</td> <td>ON</td> </tr> </tbody> </table>		LA1	LA2	LOUDNESS "ON"	ON	OFF	LOUDNESS "OFF"	OFF	ON
	LA1					LA2								
LOUDNESS "ON"	ON					OFF								
LOUDNESS "OFF"	OFF					ON								
23 (20)	R-LD1													
7 (6)	L-LD2													
22 (19)	R-LD2													
8 (7)	L-A-GND	Analog GND pin												
21 (18)	R-A-GND													
10 (9)	CS1	Chip select input pin	Up to 4 chips on the same bus can be used by switching over chip select code.	—										
19 (16)	CS2													
14 (12)	CK	Clock input pin	Data transfer clock input	Low threshold value input pin										
15 (13)	DATA	Data input pin	Volume setup serial data input											
16 (14)	STB	Strobe input pin	Data write strobe input											
2 (3)	NC	No connection	—	—										
27 (22)														
4														
25														
9 (8)														
20 (17)														
11														
18														
12 (10)														
17 (15)														

TOSHIBA CMOS DIGITAL INTEGRATED CIRCUIT SILICON MONOLITHIC

**TC9162AN, TC9163AN, TC9164AN
TC9162AF, TC9163AF, TC9164AF**

HIGH VOLTAGE ANALOG FUNCTION SWITCH ARRAY

TC9162AN/AF, TC9163AN/AF and TC9164AN/AF are analog switch arrays for high voltage application. By inputting the specified serial data, the analog switches are controlled. As each analog switch is independently controllable, switch of wide use is available.

FEATURES

- Analog switches of 16 circuits are built in, allowing to provide three types according to internal connections.
- Dual power supply of (+) and (-) can be used. In this case the switch select data is operated in a single power supply by the built-in level shifter. As the threshold level of the input inverter is designed low, interface with CMOS microcomputer is easily available.
- As the analog switches are high-voltage (30V) use and have superior linearity of on-resistance, extra low distortion and wide dynamic range can be realized.
- Owing to CMOS structure current consumption is low.
- Package is shrunk DIP 28 PIN.

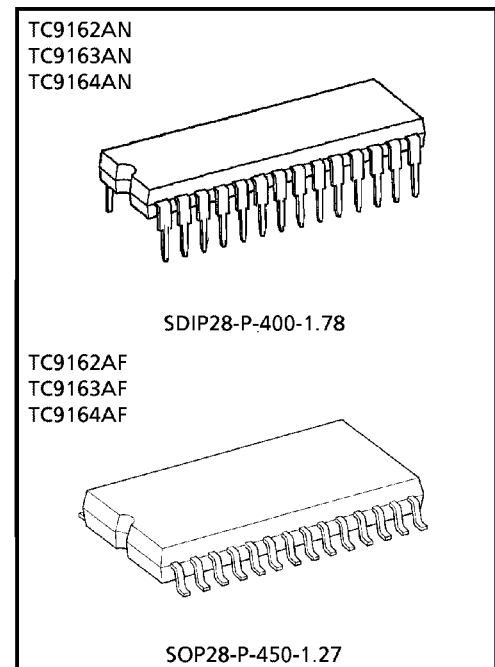

Weight
SDIP28-P-400-1.78 : 2.2g (Typ.)
SOP28-P-450-1.27 : 0.8g (Typ.)

BLOCK DIAGRAM

TC9162AN/AF

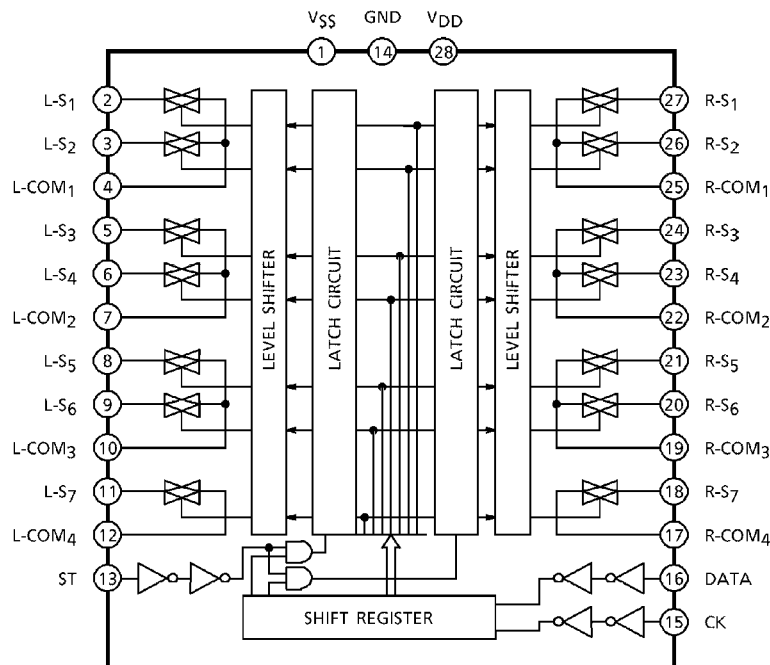

TC9163AN / AF

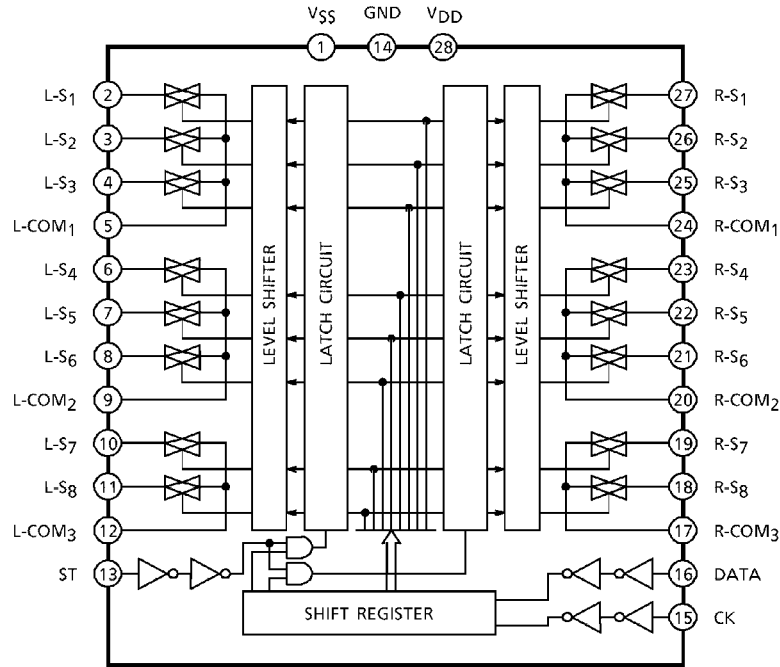

TC9164AN / AF

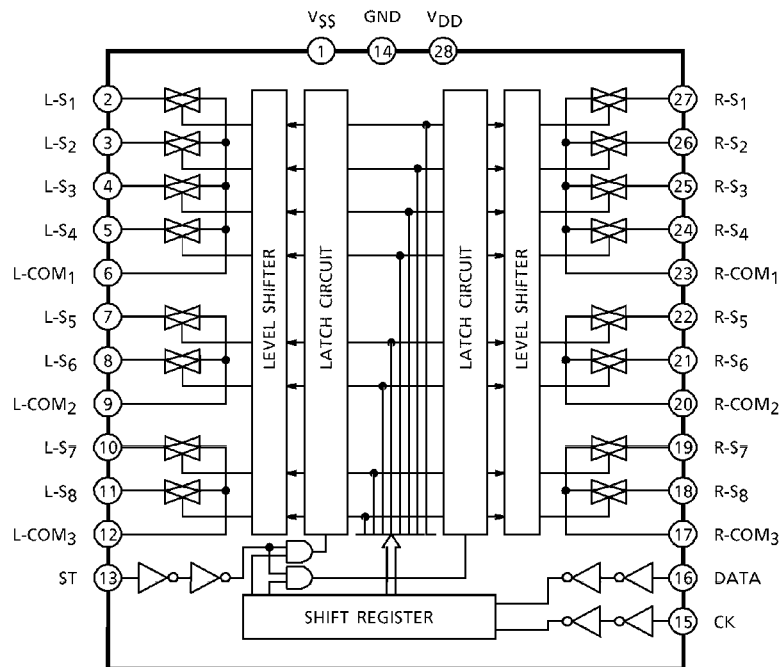

PIN CONNECTION (TOP VIEW)

TC9162AN / AF

VSS	1	28	VDD
L-S1	2	27	R-S1
L-S2	3	26	R-S2
L-COM1	4	25	R-COM1
L-S3	5	24	R-S3
L-S4	6	23	R-S4
L-COM2	7	22	R-COM2
L-S5	8	21	R-S5
L-S6	9	20	R-S6
L-COM3	10	19	R-COM3
L-S7	11	18	R-S7
L-COM4	12	17	R-COM4
ST	13	16	DATA
GND	14	15	CK

TC9163AN / AF

VSS	1	28	VDD
L-S1	2	27	R-S1
L-S2	3	26	R-S2
L-S3	4	25	R-S3
L-COM1	5	24	R-COM1
L-S4	6	23	R-S4
L-S5	7	22	R-S5
L-S6	8	21	R-S6
L-COM2	9	20	R-COM2
L-S7	10	19	R-S7
L-S8	11	18	R-S8
L-COM3	12	17	R-COM3
ST	13	16	DATA
GND	14	15	CK

TC9164AN / AF

VSS	1	28	VDD
L-S1	2	27	R-S1
L-S2	3	26	R-S2
L-S3	4	25	R-S3
L-S4	5	24	R-S4
L-COM1	6	23	R-COM1
L-S5	7	22	R-S5
L-S6	8	21	R-S6
L-COM2	9	20	R-COM2
L-S7	10	19	R-S7
L-S8	11	18	R-S8
L-COM3	12	17	R-COM3
ST	13	16	DATA
GND	14	15	CK

3-Terminal 1.5A Negative Adjustment Regulator IC

KA337

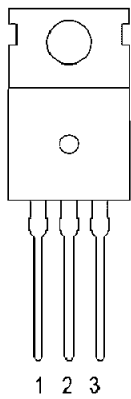

1 2 3

- 1) Adjustment
- 2) Input
- 3) Output

Low Saturation Voltage Type 3-Pin Regulator IC

BA033T

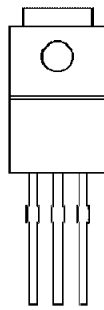

1 2 3

- 1 Vcc
- 2 Ground
- 3 Out

Photocoupler IC

PC-17T1

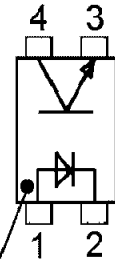

1 2

Anode Mark

POSITIVE REGULATORS VARIOUS STYLES 7805, 7806, 7812, 7815, 7824

SOT-89

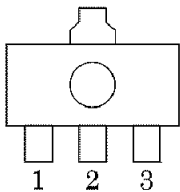

- 1. OUT
- 2. GND
- 3. IN

1 2 3

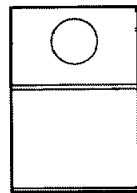

1 2 3

- 1. IN
- 2. GROUND
- 3. OUT

SO-8 Plastic (M) (Narrow Body)

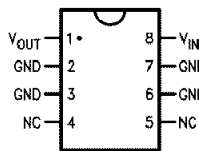

Top View

(TO-92) Plastic Package (Z)

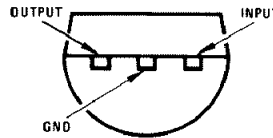

Bottom View

TO-252

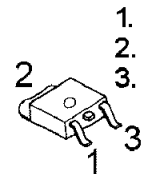

- 1. IN
- 2. GRD
- 3. OUT

1 2 3

NEGATIVE REGULATORS VARIOUS STYLES 7905, 7915

SO-8 Plastic (Narrow Body)

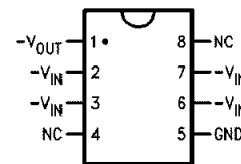

Top View

TO-92 Plastic Package (Z)

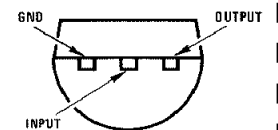

Bottom View

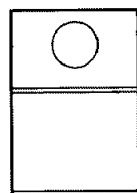

1 2 3

- 1. GROUND
- 2. IN
- 3. OUT

Silicon Transistor

2SA1859 PNP
2SC4883 NPN

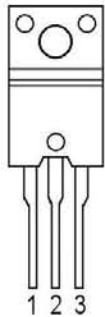

1 Base
2 Collector
3 Emitter

2SA1943
2SC5200

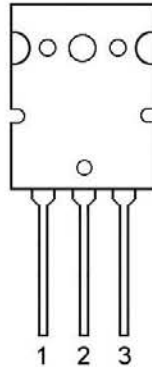

1 Base
2 Collector (Heat Sink)
3 Emitter

Silicon Transistor

2SA1986, 2SA1941, 2SB1560 PNP
2SC5198, 2SC5358, 2SD2390 NPN

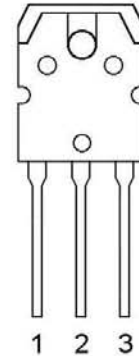

1 Base
2 Collector (Heat Sink)
3 Emitter

KTC1027
KTC3206

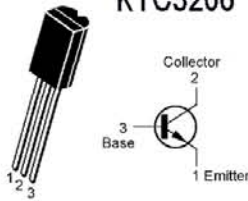

KRC107
KTA1268
KTA1266
KTA1023
KTA1024

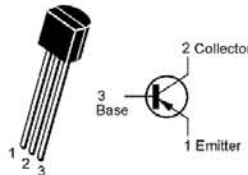

EPITAXIAL PLANAR TRANSISTOR

KTC3200
KTC2874
KTC3198
KRA107M PNP
2SA1145 PNP
2SA1370



1 Emitter
2 Collector
3 Base

Silicon Transistor

2SA1740S
2SC1740S
DTA114TSA
2SA933AS



1 Emitter
2 Collector
3 Base

MPSA06

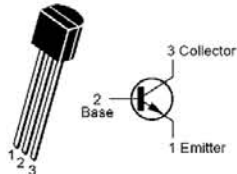

MPSA56

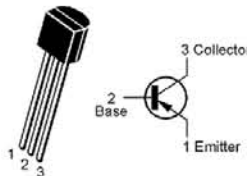

DTA114YSA
DTC114YSA NPN

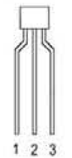

1) Ground
2) In
3) Out

KTD1302

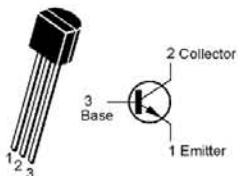

2SA1360
2SC3423

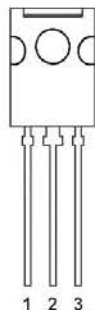

1. EMITTER
2. COLLECTOR
3. BASE

KRA107S PNP
KTD1304 NPN
KRC110S NPN
KRC111S NPN
DTC114TKA NPN
DTC114YKA NPN

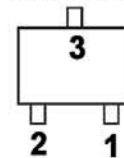

1) Emitter
2) Base
3) Collector

DTA114YKA

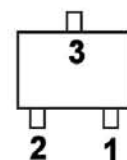

1) Ground
2) In
3) Out

Silicon NPN Transistor

DTC114TSA

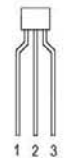

1 Emitter
2 Collector
3 Base

2SC4137



1. Emitter
2. Collector
3. Base

SCHEMATIC DIAGRAM

Harman/Kardon
AVR7200 SUPPLY

REVISION RECORD		
LTR	ECO NO:	APPROVED: DATE:

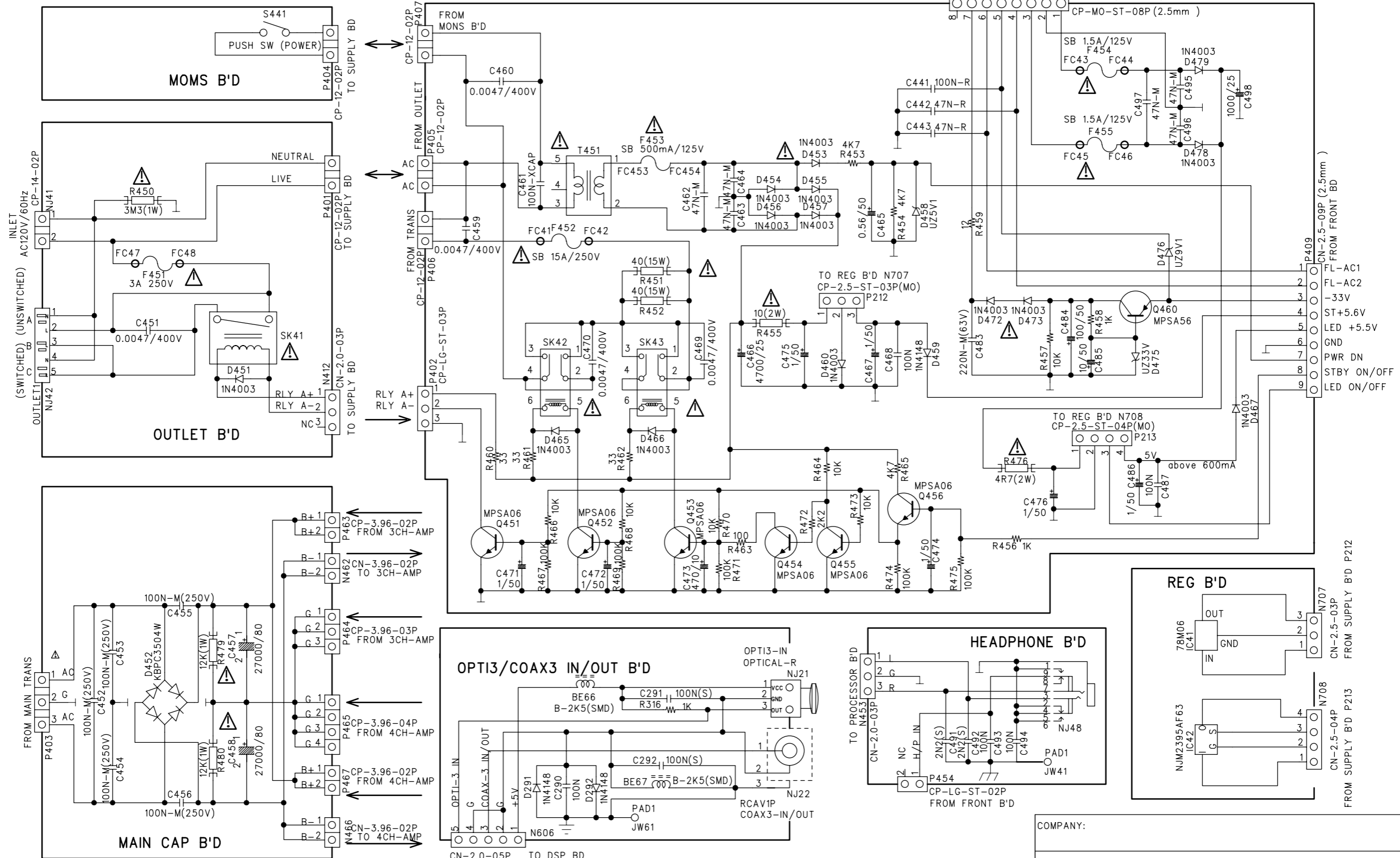

*** IMPORTANT SAFETY NOTICE. COMPONENTS IDENTIFIED BY Δ MARK HAVE SPECIAL CHARACTERISTICS IMPORTANT FOR SAFETY. WHEN REPLACING ANY OF THESE COMPONENTS USE ONLY MANUFACTURER'S SPECIFIED PARTS.
 *** THE UNIT OF RESISTANCE IS OHM.
 K=1000 OHM, M=1000 KOHM.
 *** THE UNIT OF CAPACITANCE IS MICROFARAD (μ F)
 pF=10⁻⁴ μ F
 *** THIS SCHEMATIC DIAGRAM MAY MODIFIED AT ANYTIME WITH THE IMPROVEMENT OF PERFORMANCE.

COMPANY:				
TITLE:				
AVR7200 SUPPLY				
DRAWN: KIM YANG GYOO	DATED: JAN.23.2003.	CODE:	SIZE:	DRAWING NO:
CHECKED:	DATED:	QUALITY CONTROL:	DATED:	REV:
RELEASED:	DATED:	STAGE:MP1	TOTAL SHEET: 2 OF 11	

SCHEMATIC DIAGRAM

harman/kardon

harman/kardon
AVR7200 MAIN

REVISION RECORD			
LTR	ECO NO:	APPROVED:	DATE:

AVR7200

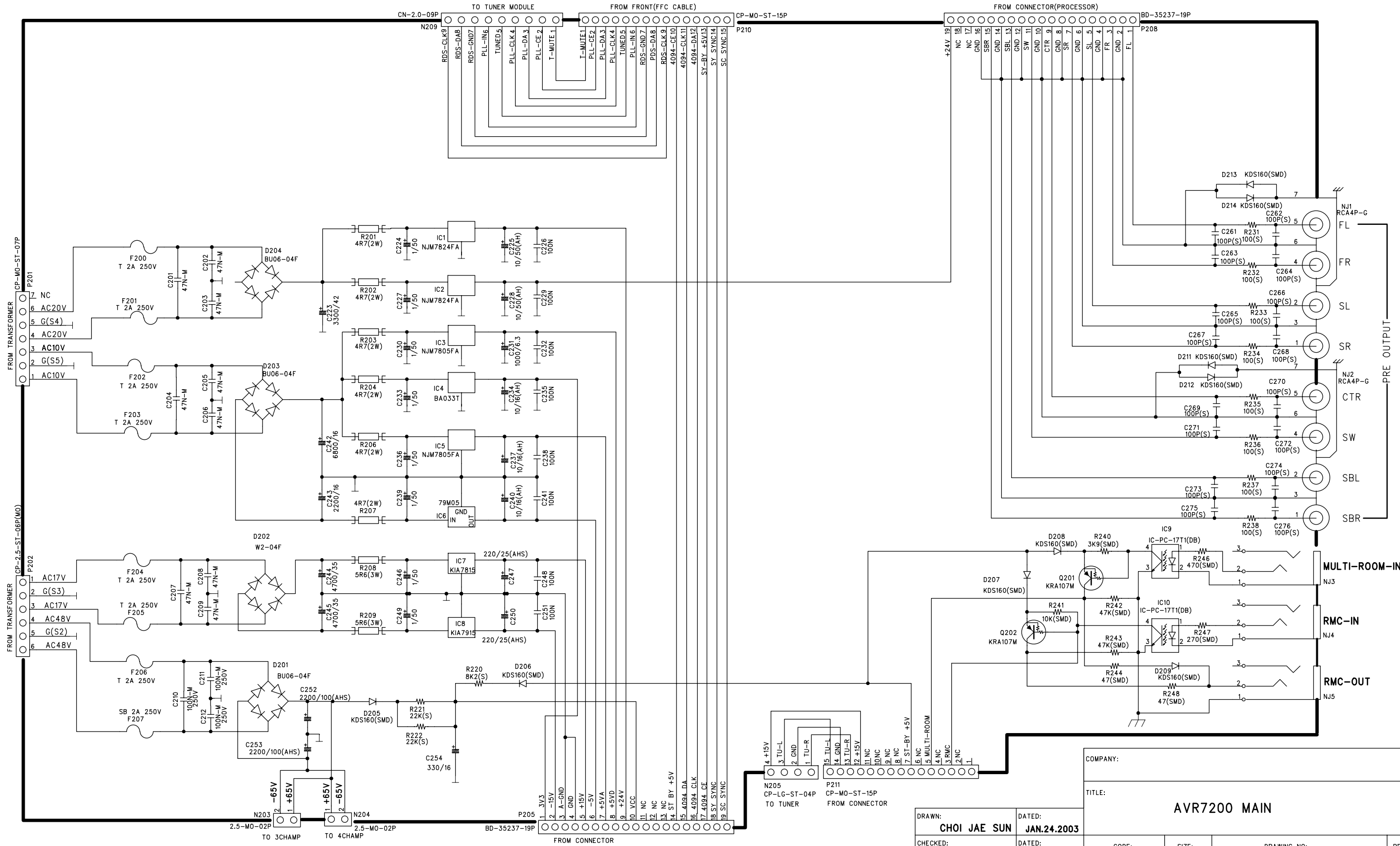

*** THE UNIT OF RESISTANCE IS OHM.
K=1000 OHM, M=1000 KOHM.
*** THE UNIT OF CAPACITANCE IS MICROFARAD (uF)
pF=10⁻⁴ uF
*** THIS SCHEMATIC DIAGRAM MAY MODIFIED AT ANYTIME WITH THE
IMPROVEMENT OF PERFORMANCE.

DRAWN: CHOI JAE SUN	DATED: JAN.24.2003
CHECKED:	DATED:
QUALITY CONTROL:	DATED:
RELEASED:	DATED:

COMPANY:			
TITLE: AVR7200 MAIN			
CODE:	SIZE:	DRAWING NO:	REV:
STAGE:MP1			TOTAL SHEET: 4 OF 11

6

5

4

3

2

1

AVR7200

SCHEMATIC DIAGRAM

harman/kardon

harman/kardon
AVR7200 CONNECTOR

REVISION RECORD			
LTR	ECO NO:	APPROVED:	DATE:

4CHAMP CONNECTOR
(ON 4CH AMP B'D)

MAIN-----VIDEO-----PROCESSOR-----DSP

CNT 1 B'D

PROCESSOR-----DSP

MAIN-----PROCESSOR-----VIDEO

CNT 2 B'D

MAIN-----PROCESSOR

3CHAMP CONNECTOR
(ON 3CH AMP B'D)

*** THE UNIT OF RESISTANCE IS OHM.
K=1000 OHM, M=1000 KOHM.
*** THE UNIT OF CAPACITANCE IS MICROFARAD (uF)
uF=10⁻⁶ uF
*** THIS SCHEMATIC DIAGRAM MAY MODIFIED AT ANYTIME WITH THE
IMPROVEMENT OF PERFORMANCE.

COMPANY:

TITLE:
AVR7200 CONNECTOR

DRAWN: EOM JAE GU	DATED: JAN.24.2003	CODE:	SIZE:	DRAWING NO:	REV:
CHECKED:	DATED:	QUALITY CONTROL:	DATED:	RELEASED:	DATED:

STAGE:MP1 TOTAL SHEET: 10 OF 11

163

REVISION RECORD			
LTR	ECO NO:	APPROVED:	DATE:

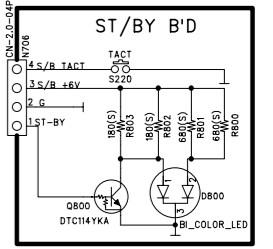
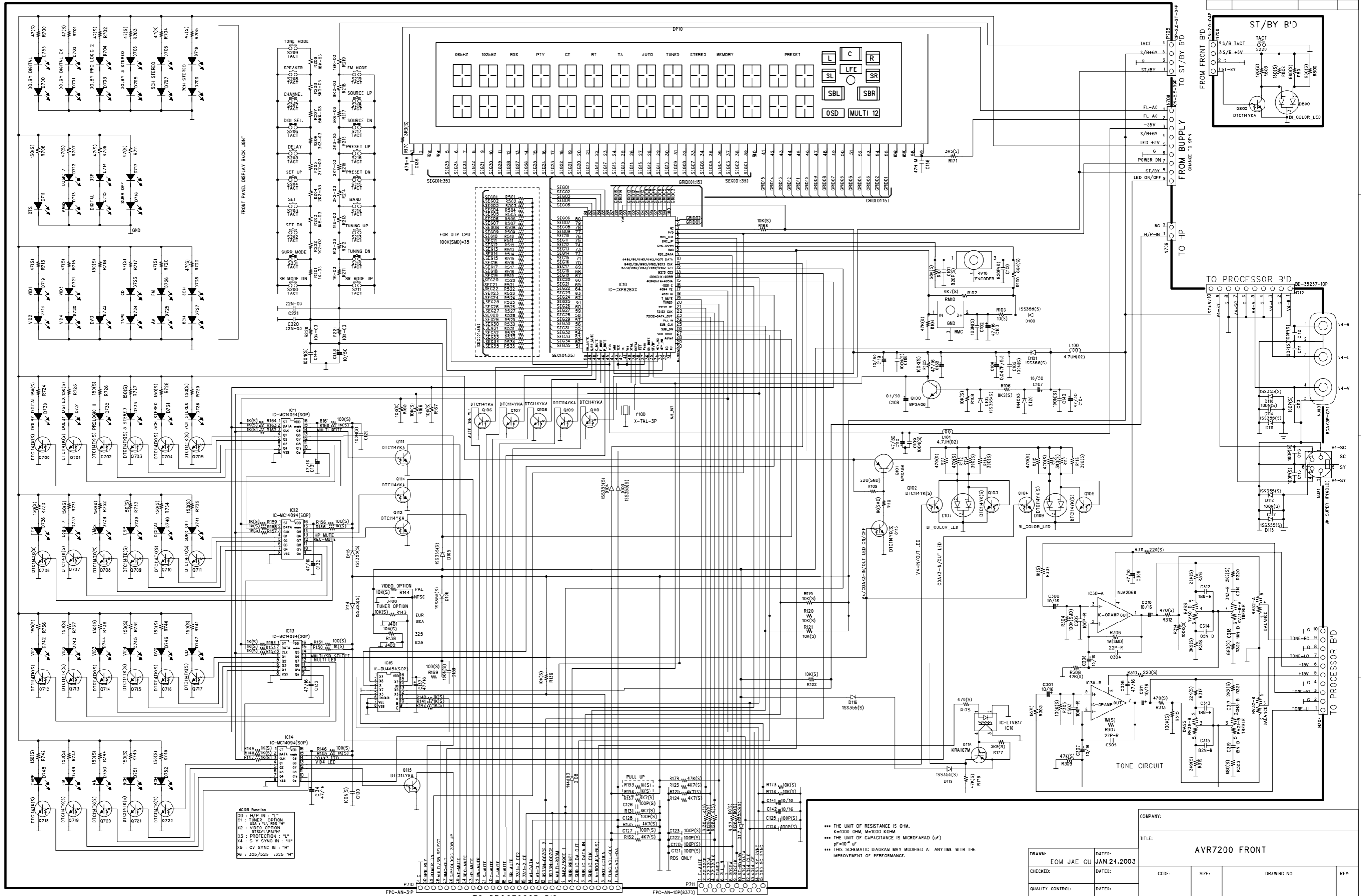

IC105 Function
 X0 : H/P IN : "L"
 X1 : TUNER OPTION
 X2 : VIDEO OPTION
 X3 : PROTECTION : "L"
 X4 : S-Y SYNC IN : "H"
 X5 : CV SYNC IN : "H"
 X6 : 325/525 :325 "H"

*** THE UNIT OF RESISTANCE IS OHM.
 K=1000 OHM, M=1000 KOHM.
 *** THE UNIT OF CAPACITANCE IS MICROFARAD (UF)
 UF=10⁻⁶UF
 *** THIS SCHEMATIC DIAGRAM MAY MODIFIED AT ANYTIME WITH THE
 IMPROVEMENT OF PERFORMANCE.

DRAWN: EOM JAE GU		DATED: JAN.24.2003	
CHECKED:	DATED:	CODE:	SIZE:
QUALITY CONTROL:	DATED:	DRAWING NO:	REV:
RELEASED:	DATED:	STAGE: MP1	TOTAL SHEET:1 OF 11

D

C

B

A

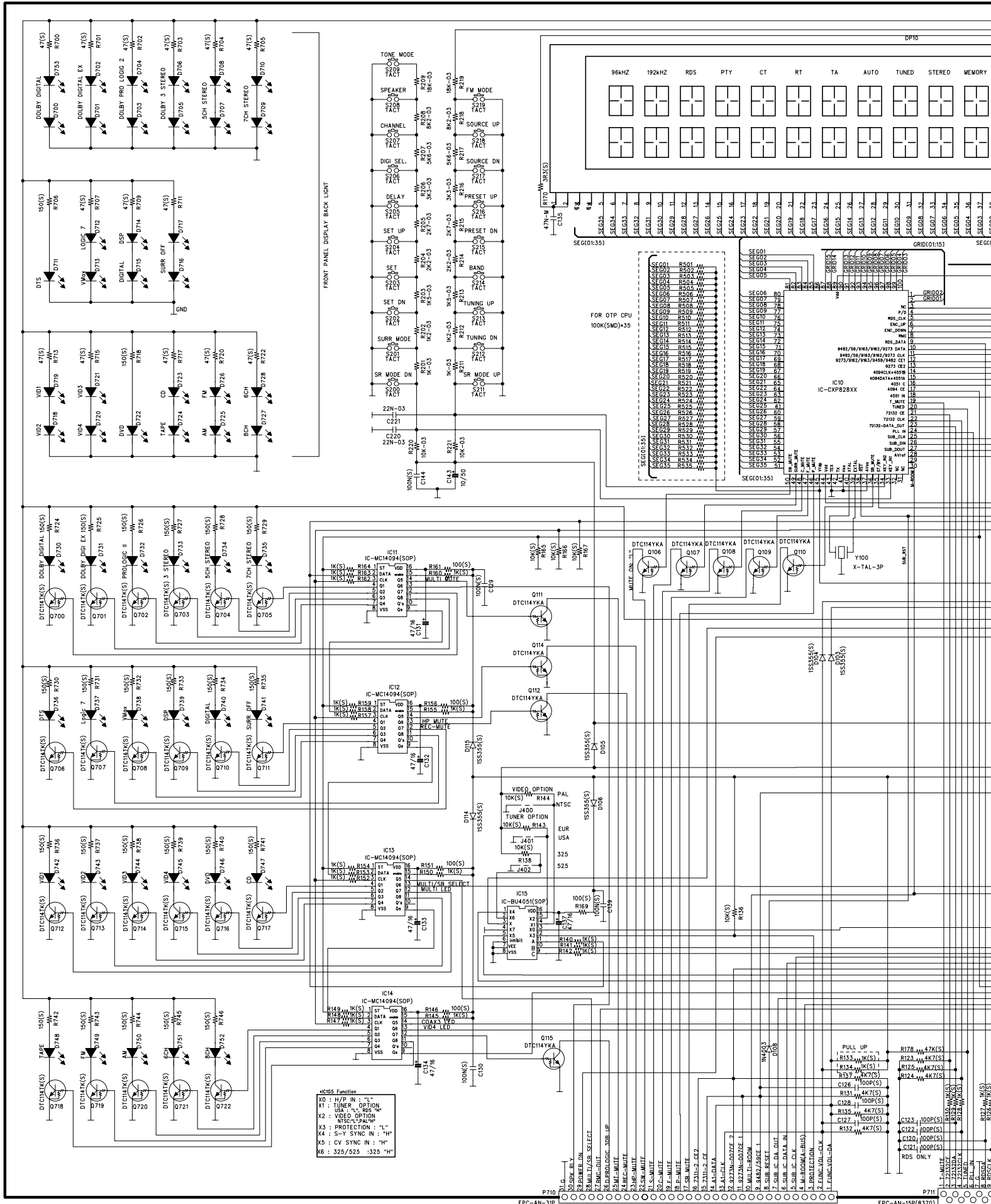

DIAGRAM

harman/kardon AVR7200 FRONT

REVISION RECORD			
LTR	ECO NO:	APPROVED:	DATE:

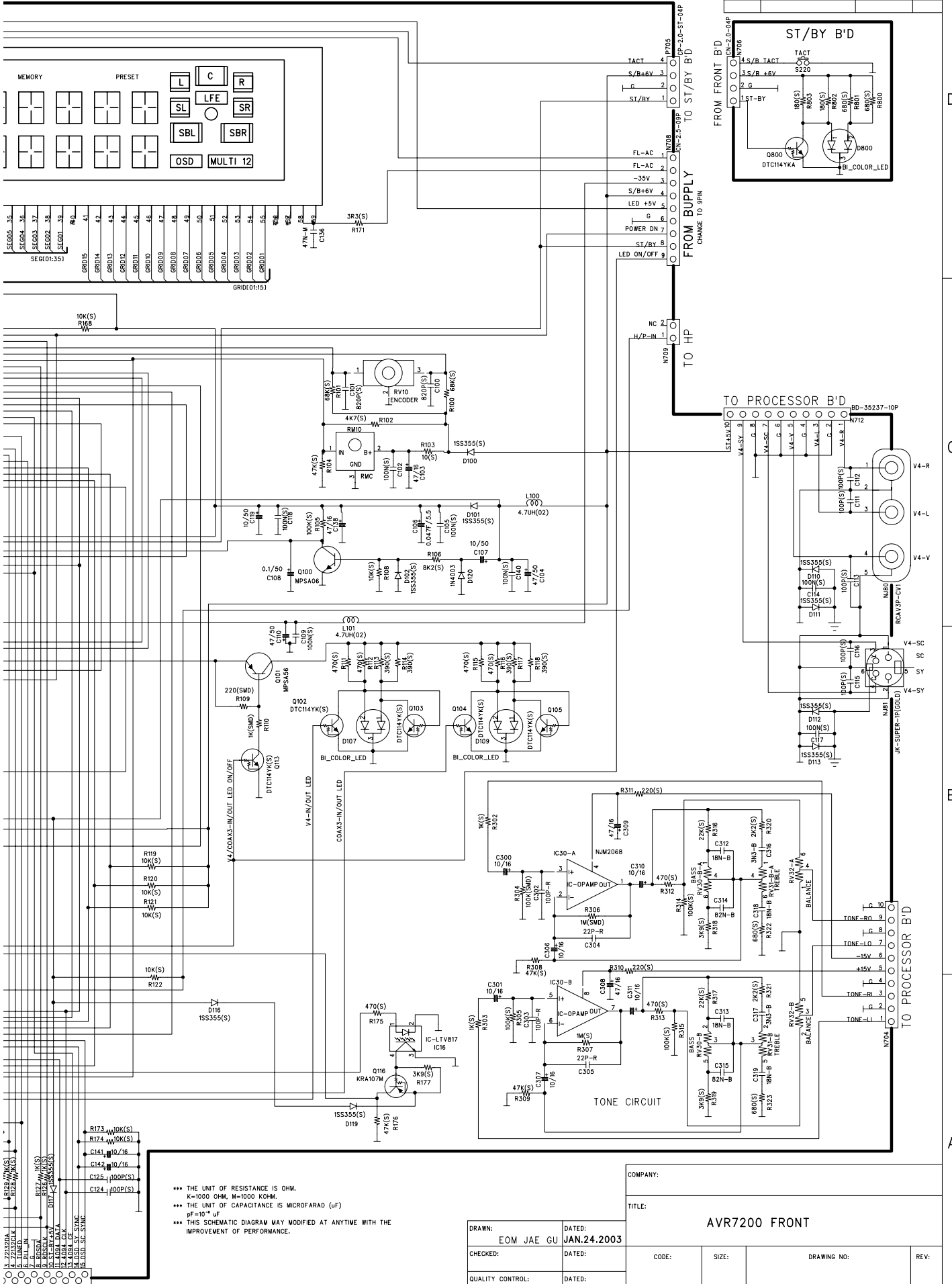

*** THE UNIT OF RESISTANCE IS OHM.
K=1000 OHM, M=1000 KOHM.
*** THE UNIT OF CAPACITANCE IS MICROFARAD (uF)
uF=10⁻⁶ uF
*** THIS SCHEMATIC DIAGRAM MAY MODIFIED AT ANYTIME WITH THE IMPROVEMENT OF PERFORMANCE.

COMPANY:		TITLE:	
EOM JAE GU		AVR7200 FRONT	
CHECKED:	DATED:	CODE:	SIZE:
	JAN.24.2003		
QUALITY CONTROL:	DATED:	DRAWING NO:	REV:
RELEASED:	DATED:	STAGE: MPI	TOTAL SHEET:1 OF 11

AVR7200

harman/kardon

SCHEMATIC DIAGRAM

harman/kardon AVR7200 VIDEO

REVISION RECORD			
LTR	ECO NO.	APPROVED:	DATE:

*** VIDEO SIGNAL FLOW:
 :CONDITION :INPUT FUNCTION: DVD
 :VIDEO4 MODE: OUT
 → : COMPOSITE VIDEO SIGNAL FLOW
 ⇨ : SUPER VIDEO SC SIGNAL FLOW.
 ⇩ : SUPER VIDEO SY SIGNAL FLOW.

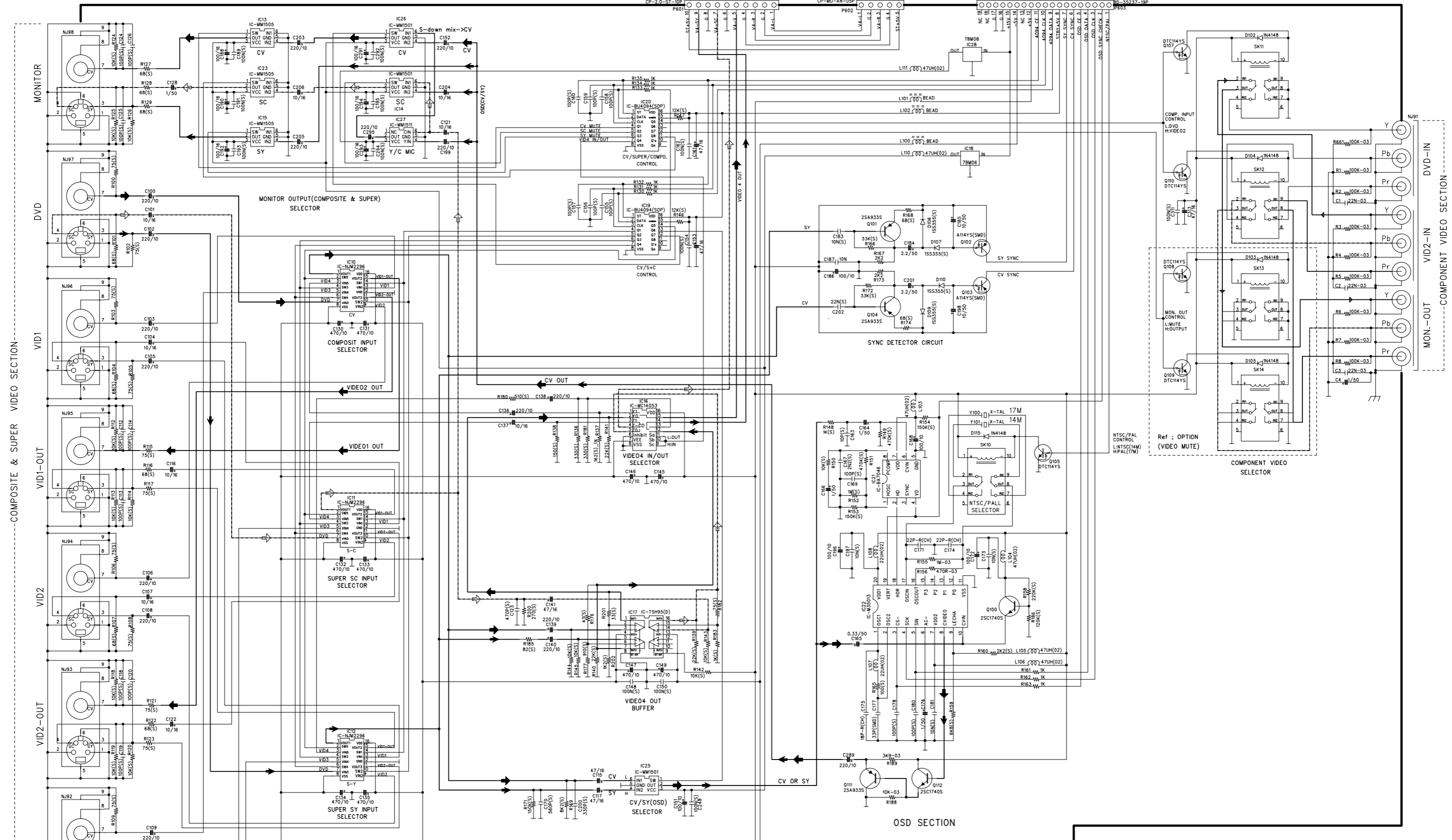

*** THE UNIT OF RESISTANCE IS OHM.
 K=1000 OHM, M=1000 KOHM.
 *** THE UNIT OF CAPACITANCE IS MICROFARAD (μF)
 pf=10⁻⁴ μF
 *** THIS SCHEMATIC DIAGRAM MAY BE MODIFIED AT ANYTIME WITH THE
 IMPROVEMENT OF PERFORMANCE.

DRAWN: EOM JAE GU		DATED: JAN.24.2003		COMPANY: harman/kardon	
CHECKED:		DATED:		CODE:	
QUALITY CONTROL:		DATED:		SIZE:	
RELEASED:		DATED:		DRAWING NO:	
				REV:	
				STAGE:MP1	TOTAL SHEET:7 OF 11

AVR7200

harman/kardon

SCHEMATIC DIAGRAM

harman/kardon
AVR7200 PROCESSOR

REVISION RECORD			
LTR	ECC NO.	APPROVED:	DATE:

*** SIGNAL FLOW DIAGRAM
FUNCTION:CD_SURR OFF MODE,TONE OUT
CURRENT SIGNAL FLOW
MODE CHANGE SIGNAL FLOW

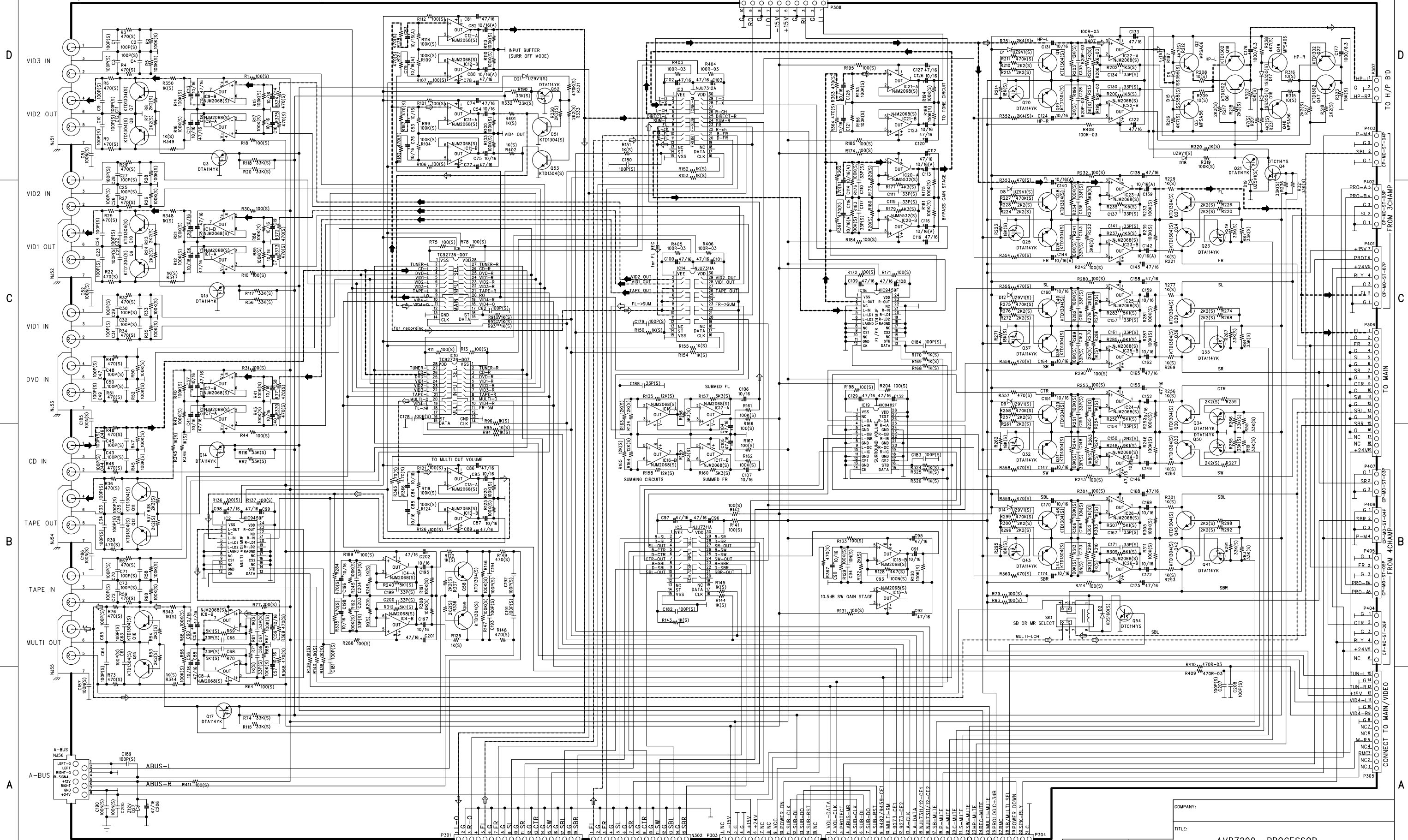

*** THE UNIT OF RESISTANCE IS OHM.
K=1000 OHM, M=1000 KOHM
*** THE UNIT OF CAPACITANCE IS MICROFARAD (uF)
pF=10⁻¹² uF
*** THIS SCHEMATIC DIAGRAM MAY BE MODIFIED AT ANYTIME WITH THE
IMPROVEMENT OF PERFORMANCE.

DRAWN: EOM JAE GU JAN.24.2003		DATED:	
CHECKED:	DATED:	CODE:	SIZE:
QUALITY CONTROL:	DATED:	DRAWING NO.:	REV.:
RELEASED:	DATED:	STAGE:MP1	TOTAL SHEET:3 OF 11

AVR7200

harman/kardon

*** SIGNAL FLOW DIAGRAM
 FUNCTION:CD, SURR OFF MODE, TONE OUT
 ● : CURRENT SIGNAL FLOW
 ⇨ : MODE CHANGE SIGNAL FLOW

D
VID3 IN
VID2 OUT
VID2 IN
VID1 OUT
VID1 IN
DVD IN
CD IN
TAPE OUT
TAPE IN
MULTI OUT
A-BUS
A-BUS

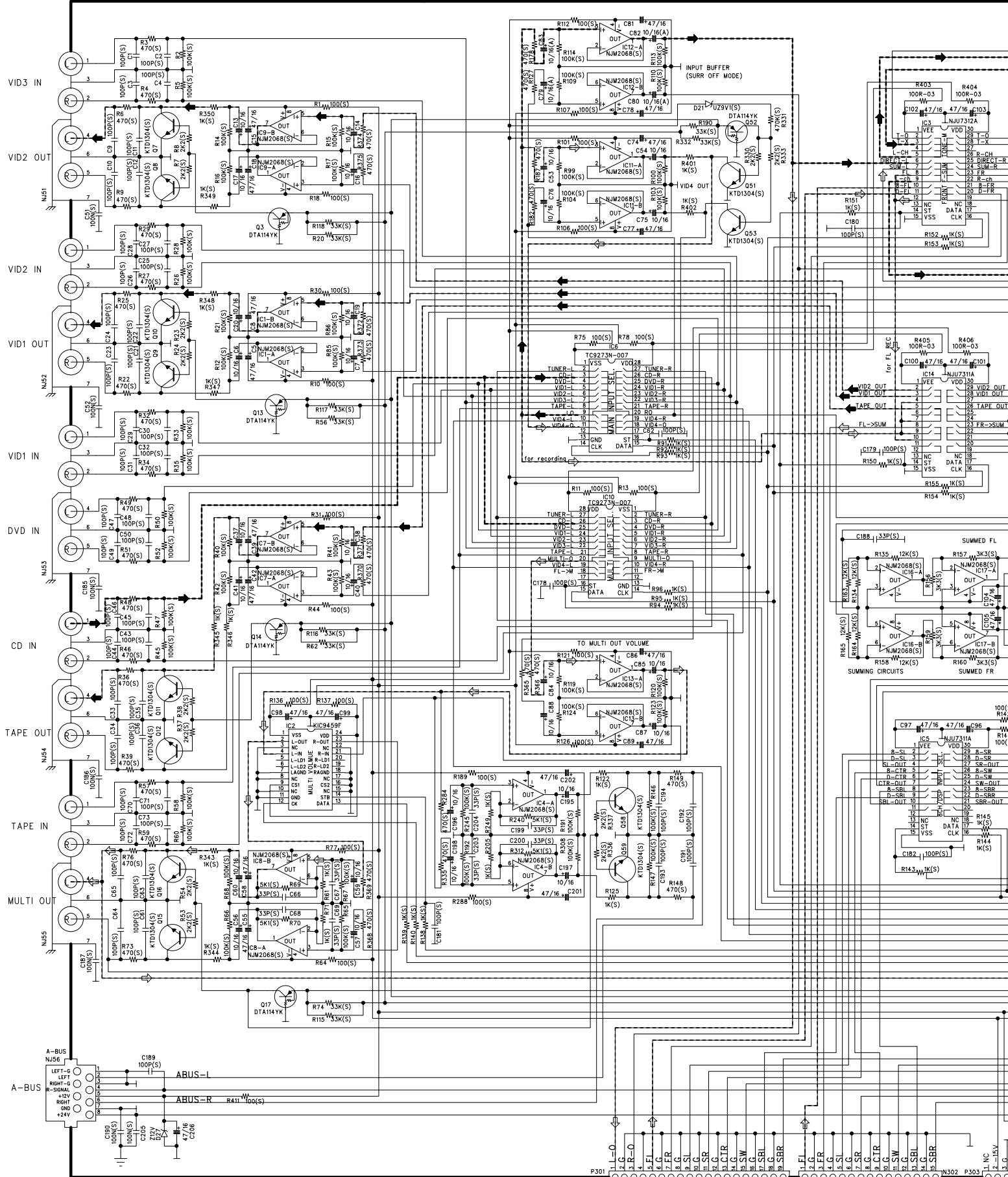

*** THE UNIT OF RESISTANCE IS OHM.
 K=1000 OHM, M=1000 KOHM.
 *** THE UNIT OF CAPACITANCE IS MICROFARAD (uF)
 uF=10⁻⁶ F
 *** THIS SCHEMATIC DIAGRAM MAY MODIFIED AT ANYTIME WITH THE
 IMPROVEMENT OF PERFORMANCE.

DIAGRAM

harman/kardon AVR7200 PROCESSOR

REVISION RECORD			
LTR	ECO NO:	APPROVED:	DATE:

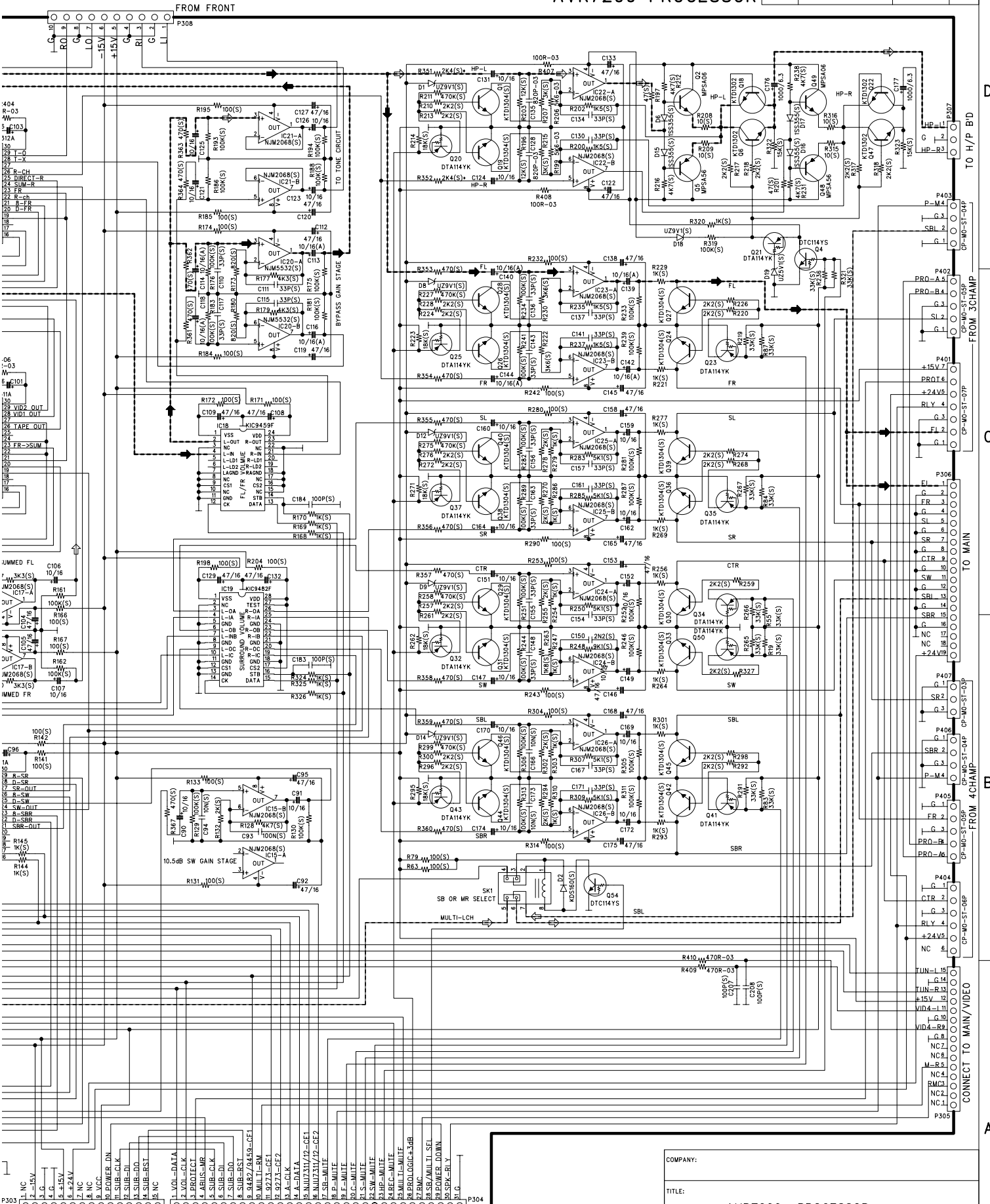

- 1. NC
- 2. +1.5V
- 3. G
- 4. G
- 5. +1.5V
- 6. +2.5V
- 7. NC
- 8. NC
- 9. G.C.C.
- 10. EDWDR DN
- 11. SUB-CLK
- 12. PROTECT
- 13. SUB-DO
- 14. SUB-BST
- 15. NC
- 16. 1 VOL-DATA
- 17. 2 VOL-CLK
- 18. 3 PROTECT
- 19. 4 SUB-CLK
- 20. 5 SUB-DO
- 21. 6 SUB-BST
- 22. 7 SUB-DO
- 23. 8 SUB-BST
- 24. 9 0482/0450-CE1
- 25. 10 MULTI-RM
- 26. 11 9273-CE1
- 27. 12 A-CLK
- 28. 13 A-DATA
- 29. 14 MULTI-SEL
- 30. 15 9273-CE2
- 31. 16 SR-MUTE
- 32. 17 SR-MUTE
- 33. 18 P-MUTE
- 34. 19 C-MUTE
- 35. 20 C-MUTE
- 36. 21 S-MUTE
- 37. 22 S-MUTE
- 38. 23 REC-MUTE
- 39. 24 REC-MUTE
- 40. 25 REC-MUTE
- 41. 26 REC-MUTE
- 42. 27 REC-MUTE
- 43. 28 REC-MUTE
- 44. 29 REC-MUTE
- 45. 30 REC-MUTE
- 46. 31 REC-MUTE
- 47. 32 REC-MUTE
- 48. 33 REC-MUTE
- 49. 34 REC-MUTE
- 50. 35 REC-MUTE
- 51. 36 REC-MUTE
- 52. 37 REC-MUTE
- 53. 38 REC-MUTE
- 54. 39 REC-MUTE
- 55. 40 REC-MUTE

COMPANY: _____

TITLE: AVR7200 PROCESSOR

DRAWN: EOM JAE GU DATED: JAN.24.2003

CHECKED: _____ DATED: _____

QUALITY CONTROL: _____ DATED: _____

RELEASED: _____ DATED: _____

CODE:	SIZE:	DRAWING NO:	REV:

STAGE:MP1

TOTAL SHEET:3 OF 11

REVISION RECORD			
LTR	ECCO NO:	APPROVED:	DATE:

D

C

B

A

D

C

B

A

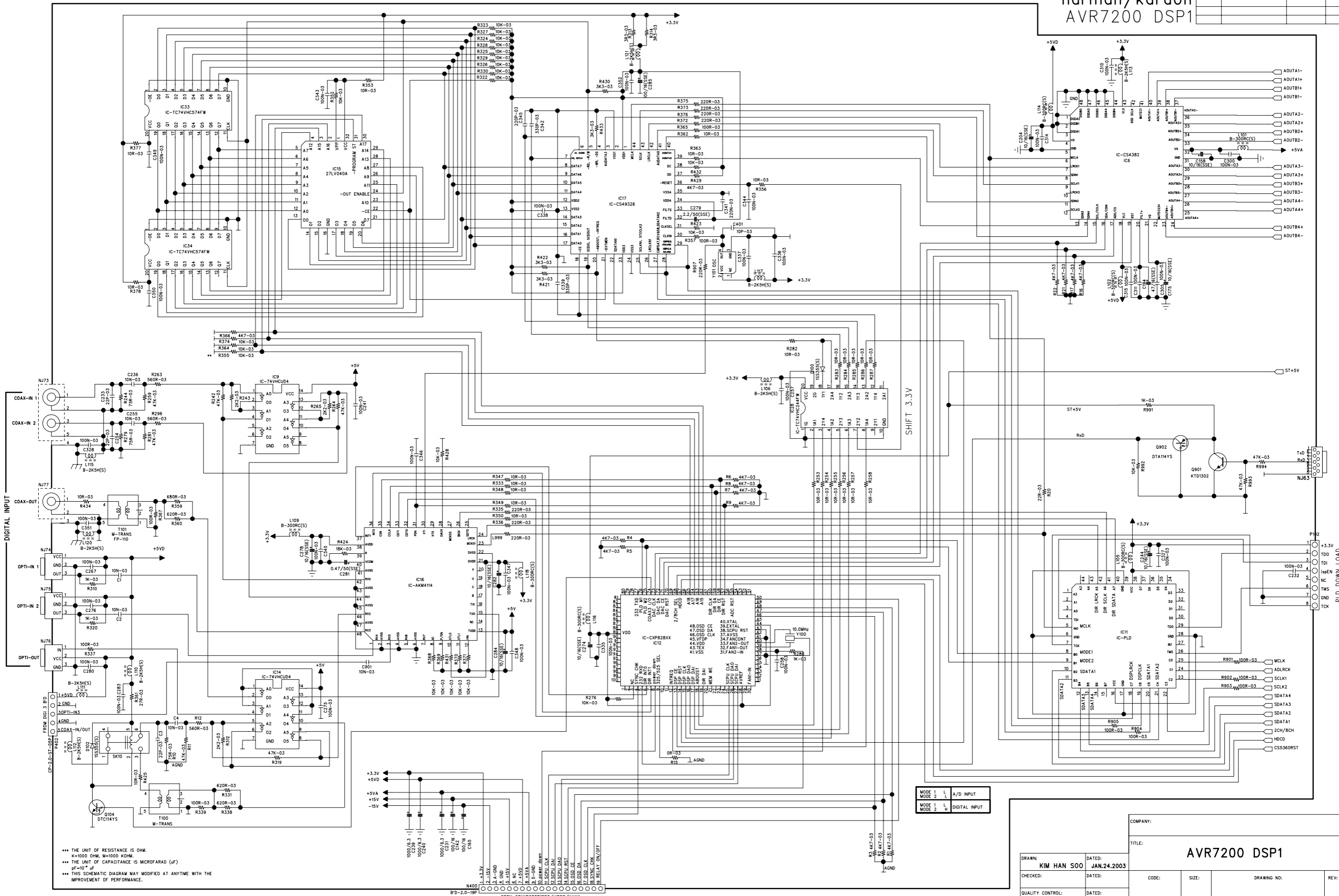

*** THE UNIT OF RESISTANCE IS OHM.
 K=1000 OHM, M=1000 KOHM.
 *** THE UNIT OF CAPACITANCE IS MICROFARAD (uF)
 pF=10⁻¹² uF
 *** THIS SCHEMATIC DIAGRAM MAY BE MODIFIED AT ANYTIME WITH THE
 IMPROVEMENT OF PERFORMANCE.

MODE 1	L	A/D INPUT
MODE 2	L	A/D INPUT
MODE 1	L	DIGITAL INPUT
MODE 2	L	DIGITAL INPUT

DRAWN:	KIM HAN SOO	DATED:	JAN.24.2003
CHECKED:		DATED:	
QUALITY CONTROL:		DATED:	
RELEASED:		DATED:	

COMPANY:			
TITLE:	AVR7200 DSP1		
CODE:		SIZE:	
DRAWING NO:		REV:	
STAGE:MP1		TOTAL SHEET:	5 OF 11

AVR7200

harman/kardon

D

C

B

A

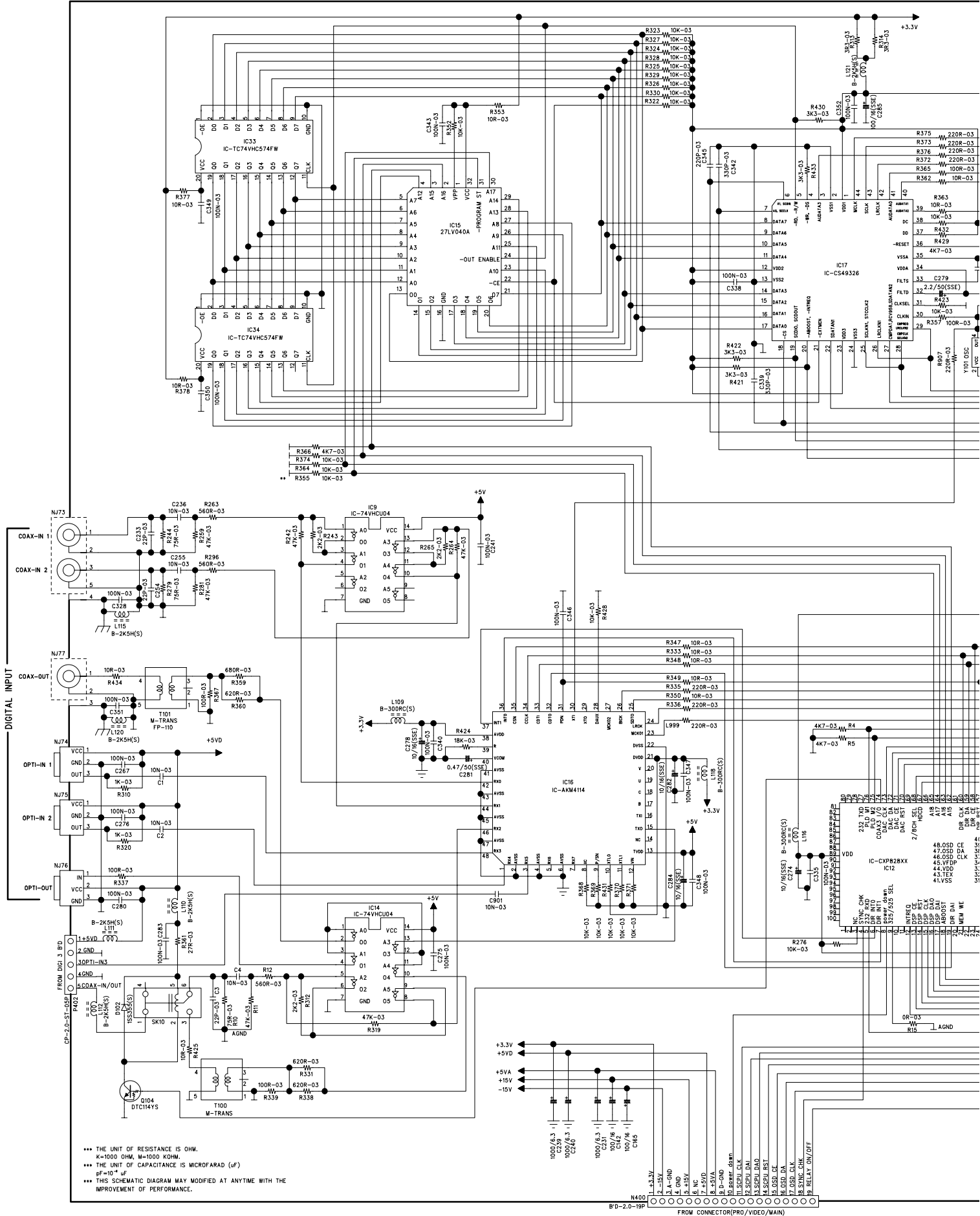

AM

harman/kardon AVR7200 DSP1

REVISION RECORD			
LTR	ECO NO:	APPROVED:	DATE:

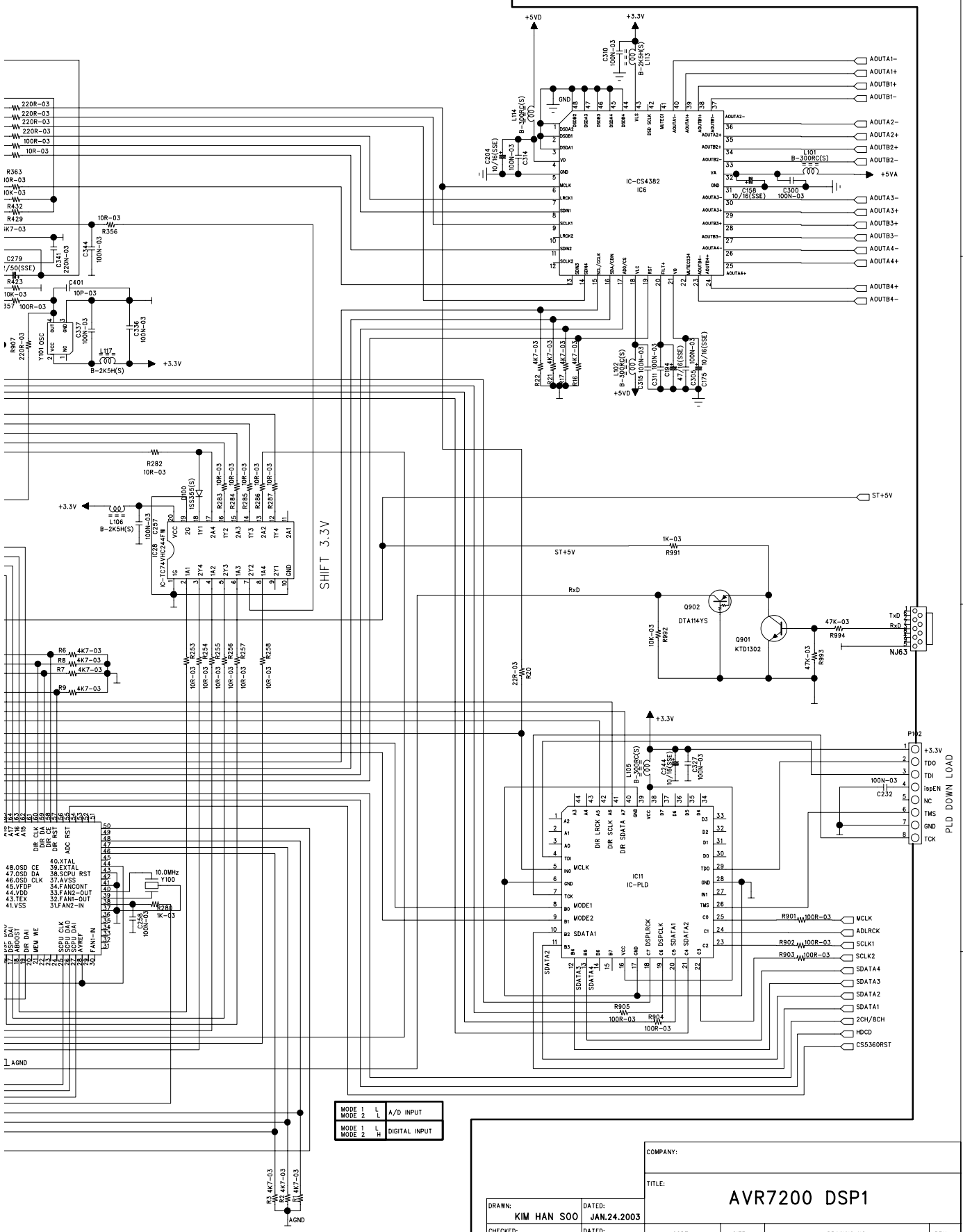

MODE 1	L	A/D INPUT
MODE 2	L	DIGITAL INPUT
MODE 1	L	DIGITAL INPUT
MODE 2	H	DIGITAL INPUT

DRAWN: KIM HAN SOO		DATED: JAN.24.2003	
CHECKED:	DATED:	CODE:	SIZE:
QUALITY CONTROL:	DATED:	DRAWING NO:	REV:
RELEASED:	DATED:	STAGE:MP1	TOTAL SHEET: 5 OF 11

COMPANY: **harman/kardon**
TITLE: **AVR7200 DSP1**

REVISION RECORD			
LTR	ECO NO.	APPROVED:	DATE:

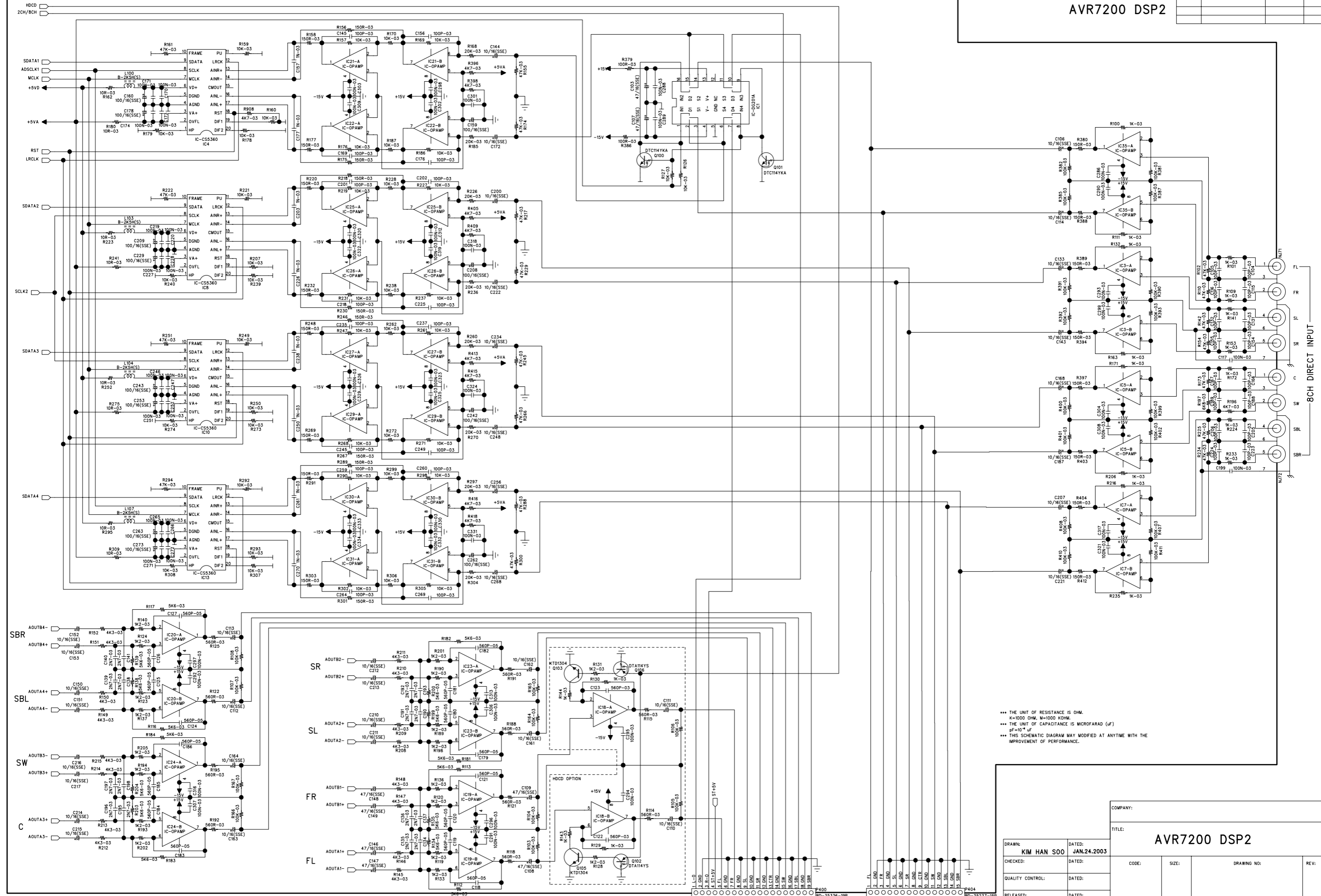

*** THE UNIT OF RESISTANCE IS OHM.
 K=1000 OHM, M=1000 KOHM.
 *** THE UNIT OF CAPACITANCE IS MICROFARAD (UF)
 P=10^-12 F
 *** THIS SCHEMATIC DIAGRAM MAY MODIFIED AT ANYTIME WITH THE
 IMPROVEMENT OF PERFORMANCE.

DRAWN: KIM HAN SOO		DATED: JAN.24.2003	
CHECKED:		DATED:	
QUALITY CONTROL:		DATED:	
RELEASED:		DATED:	
COMPANY: harman/kardon			
TITLE: AVR7200 DSP2			
CODE:	SIZE:	DRAWING NO:	REV:
STAGE:MP1		TOTAL SHEET: 6 OF 11	

D

C

B

SBR

SBL

SW

A

SR

SL

FR

FL

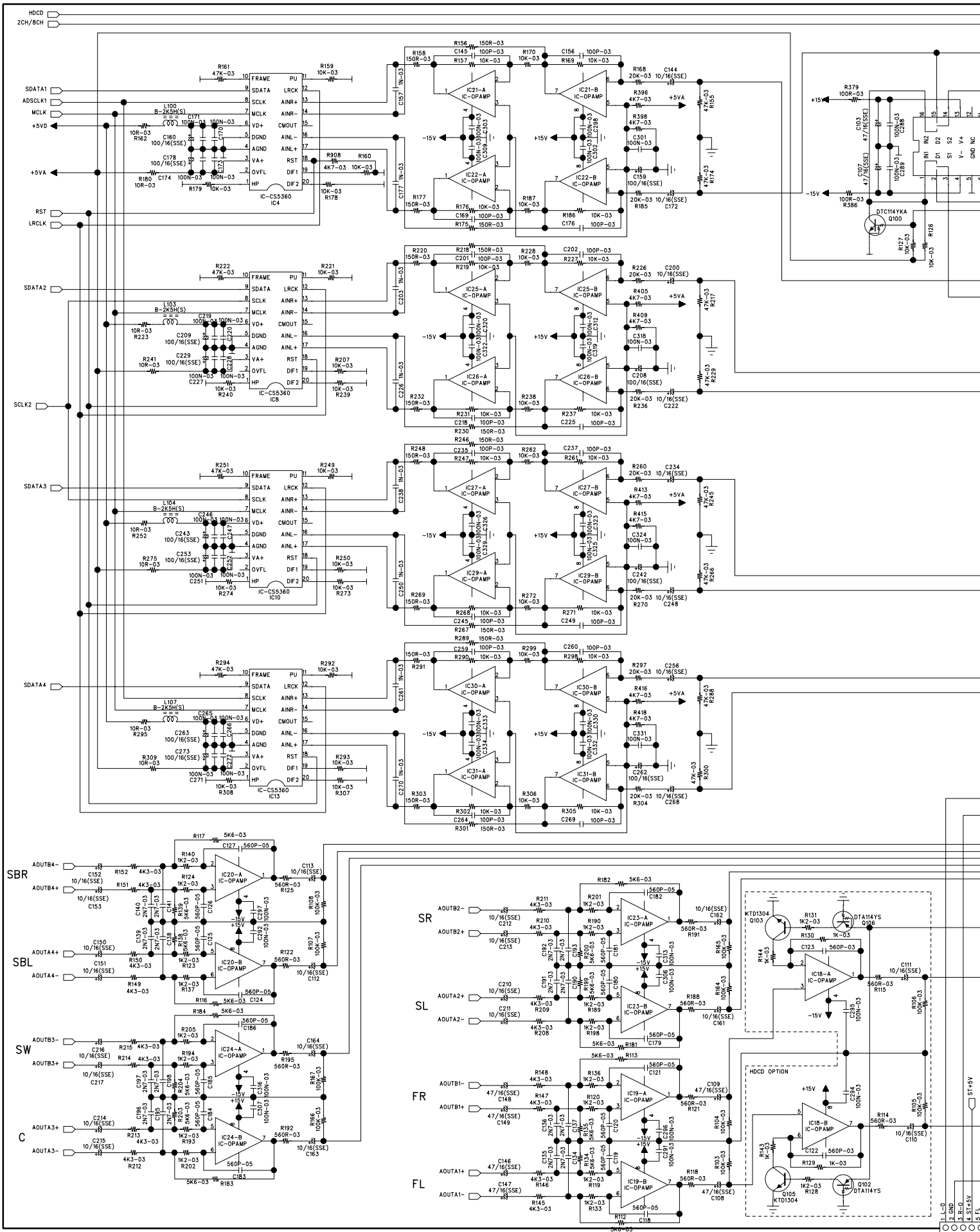

DIAGRAM

harman/karman AVR7200 DSP2

REVISION RECORD			
LTR	ECO NO:	APPROVED:	DATE:

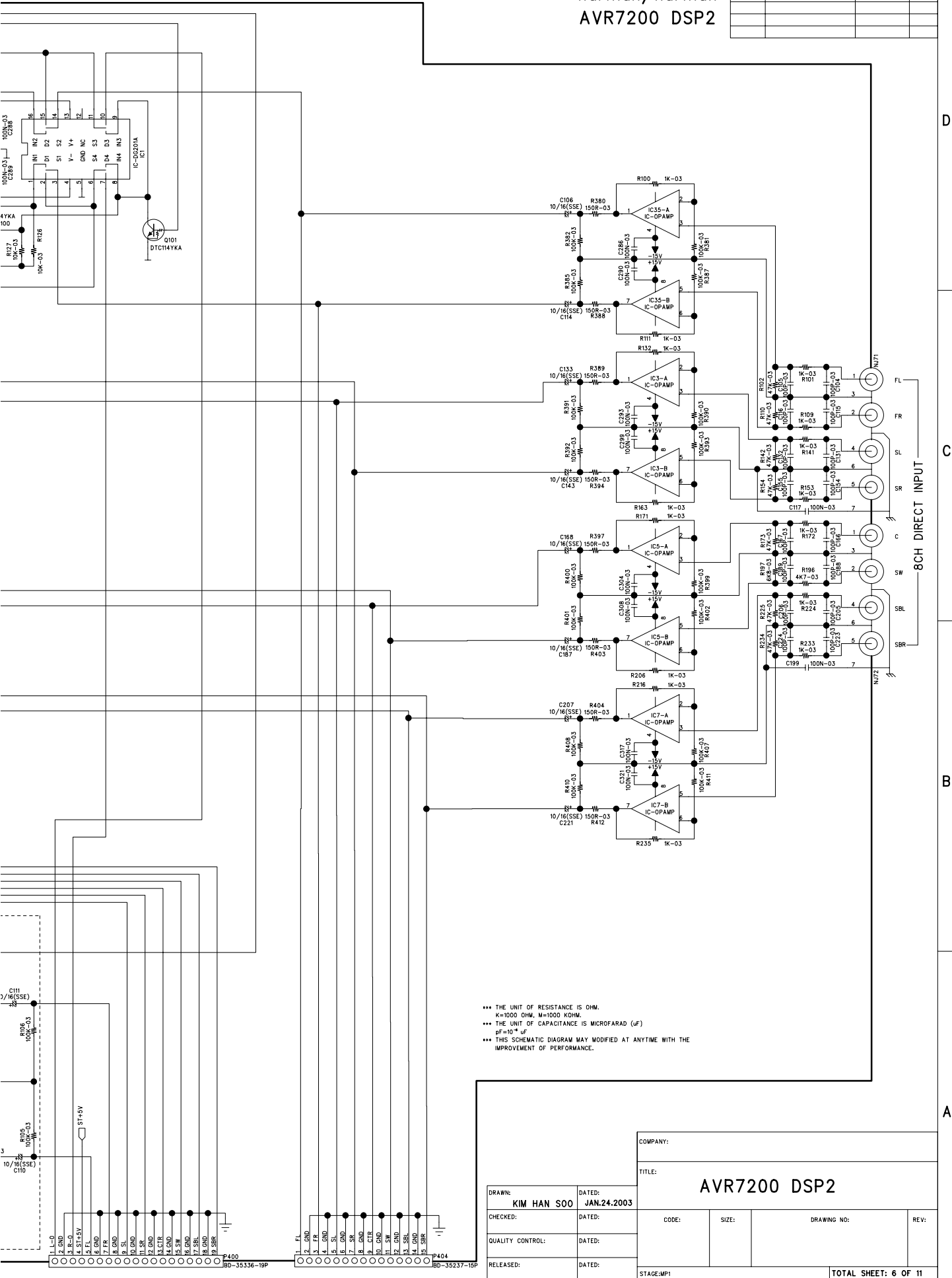

*** THE UNIT OF RESISTANCE IS OHM.
 K=1000 OHM, M=1000 KOHM.
 *** THE UNIT OF CAPACITANCE IS MICROFARAD (uF)
 pF=10⁻¹² F
 *** THIS SCHEMATIC DIAGRAM MAY MODIFIED AT ANYTIME WITH THE
 IMPROVEMENT OF PERFORMANCE.

COMPANY:		TITLE: AVR7200 DSP2		
DRAWN: KIM HAN SOO	DATED: JAN.24.2003	CODE:	SIZE:	DRAWING NO:
CHECKED:	DATED:	RELEASED:	DATED:	REV:
QUALITY CONTROL:	DATED:	STAGE:MP1		TOTAL SHEET: 6 OF 11

SCHEMATIC DIAGRAM

REVISION RECORD		
LTR	ECO NO.	APPROVED/DATE

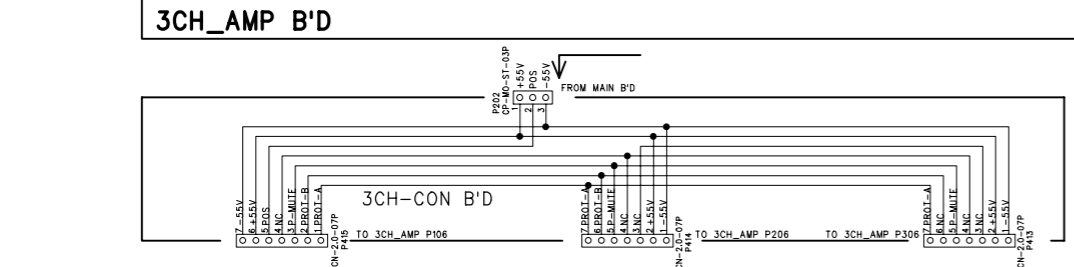
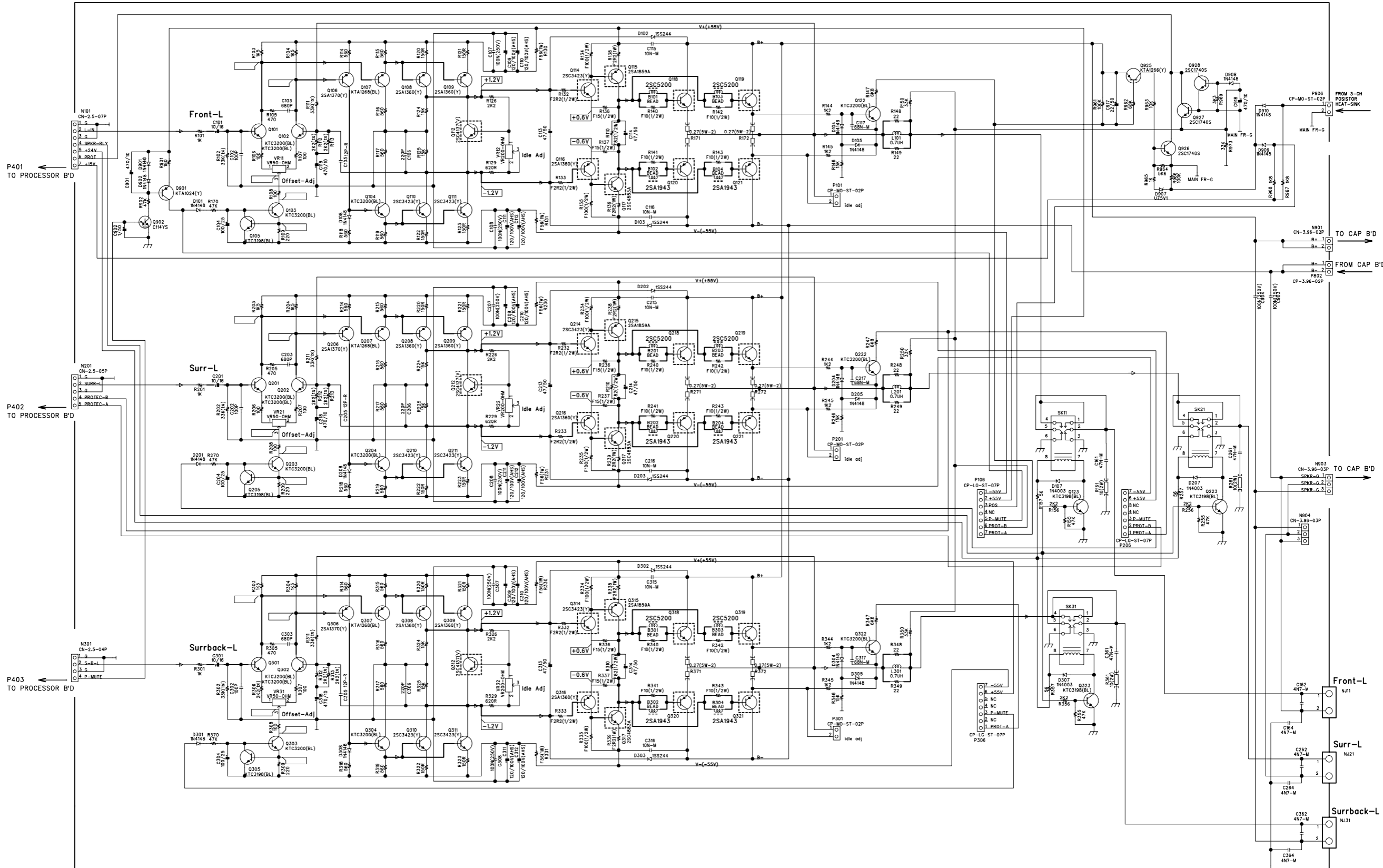

--- THE UNIT OF RESISTANCE IS OHM.
 --- THE UNIT OF CAPACITANCE IS MICROFARAD (UF)
 --- THIS SCHEMATIC DIAGRAM MAY BE MODIFIED AT ANYTIME WITH THE IMPROVEMENT OF PERFORMANCE.

DRAWN: KIM YANG GYOO		DATED: MAR.07.2003.	
CHECKED:		DATED:	
QUALITY CONTROL:		DATED:	
RELEASED:		DATED:	
COMPANY: harman/kardon			
TITLE: AVR7200 3CH AMP			
CODE:	SIZE:	DRAWING NO:	REV:
		55XXXXXX	
STAGE:MP2		SHEET: 8 OF 11	

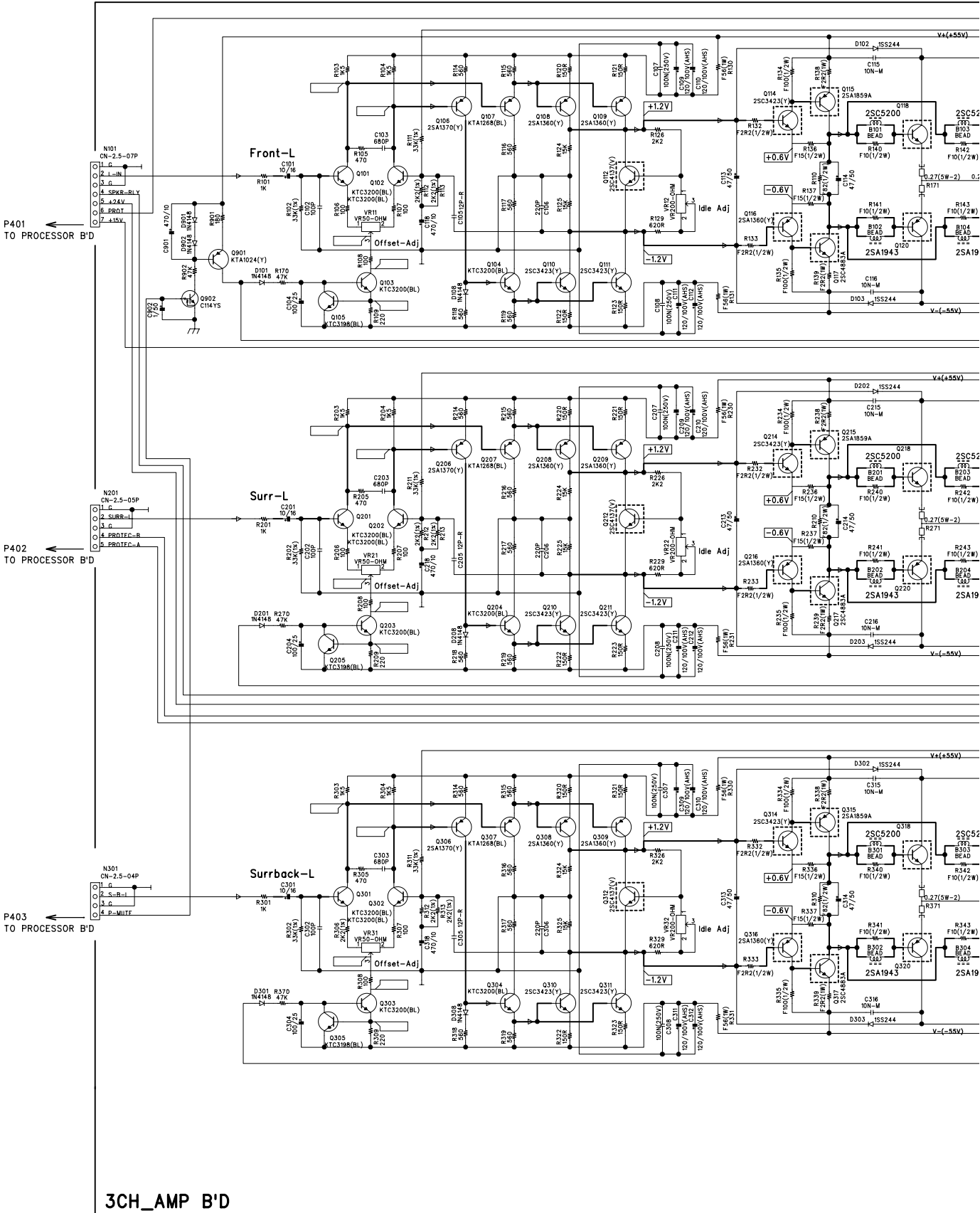

3CH_AMP B'D

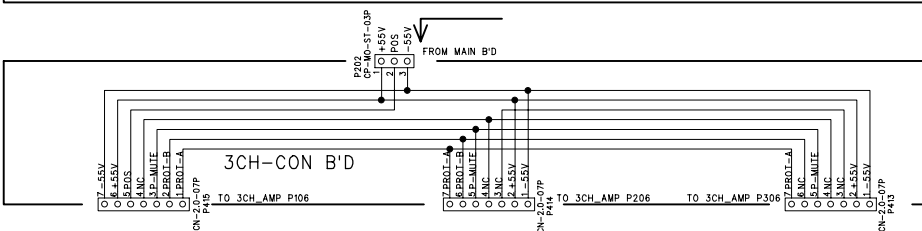

3CH-CON B'D

*** THE UNIT OF RESISTANCE IS OHM.
 K=1000 OHM, M=10000 OHM.
 *** THE UNIT OF CAPACITANCE IS MICROFARAD (UF)
 P=10 P
 *** THIS SCHEMATIC DIAGRAM MAY BE MODIFIED AT ANYTIME WITH THE
 IMPROVEMENT OF PERFORMANCE.

REVISION RECORD			
LTR	ECO NO.	APPROVED	DATE

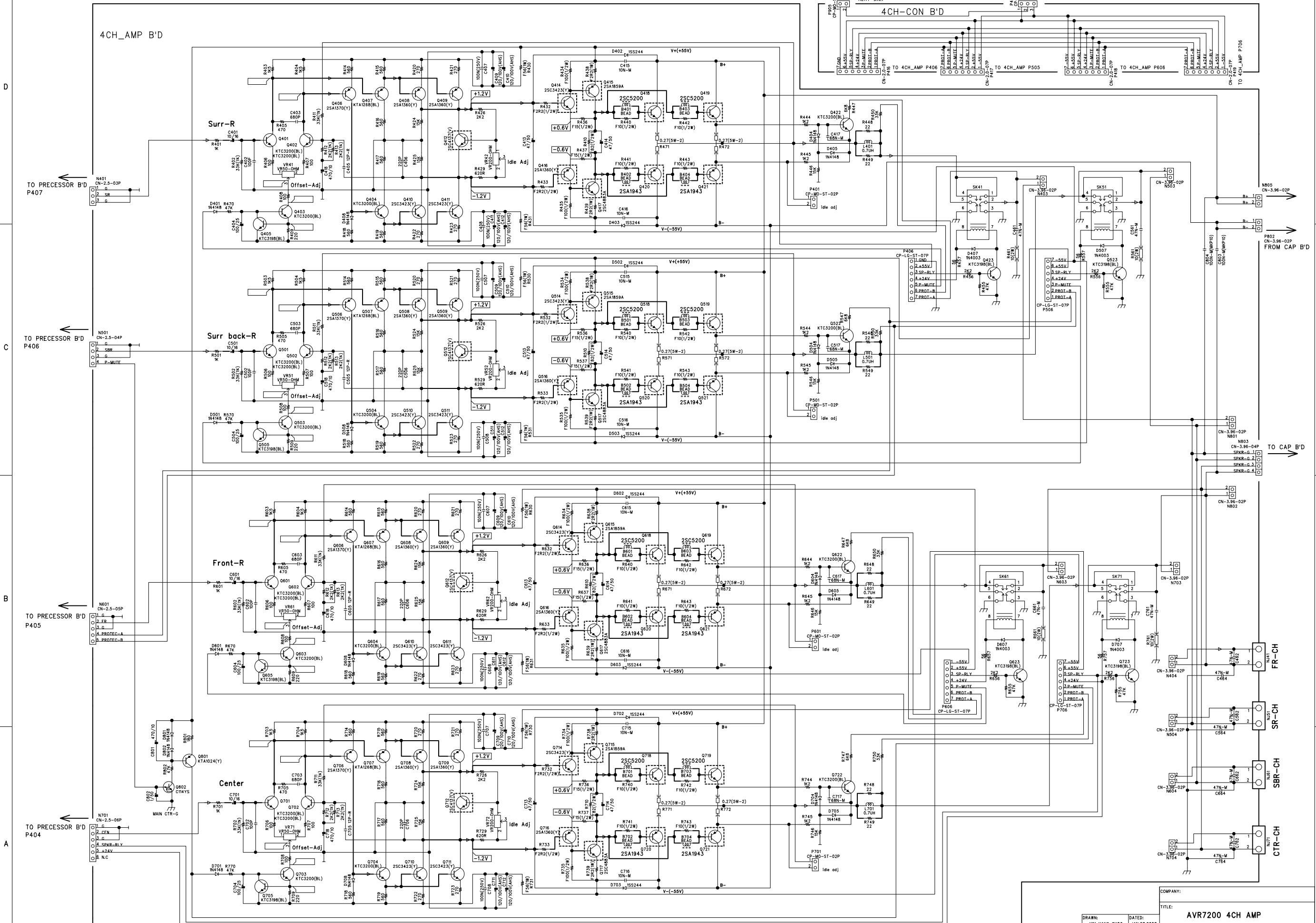

*** THE UNIT OF RESISTANCE IS OHM.
K=1000 OHM, M=1000 K OHM.
*** THE UNIT OF CAPACITANCE IS MICROFARAD (UF)
NF=10⁻⁹ F
*** THIS SCHEMATIC DIAGRAM MAY MODIFIED AT ANYTIME WITH THE
IMPROVEMENT OF PERFORMANCE.

DRAWN: KM YANG GYDO		DATED: JAN.23.2003.		TITLE: AVR7200 4CH AMP	
CHECKED:		DATED:		CODE:	
QUALITY CONTROL:		DATED:		SIZE:	
RELEASED:		DATED:		DRAWING NO:	55XXXXXX
				REV:	A

4CH_AMP B'D

D

C

B

A

TO PRECESSOR B'D P407

TO PRECESSOR B'D P406

TO PRECESSOR B'D P405

TO PRECESSOR B'D P404

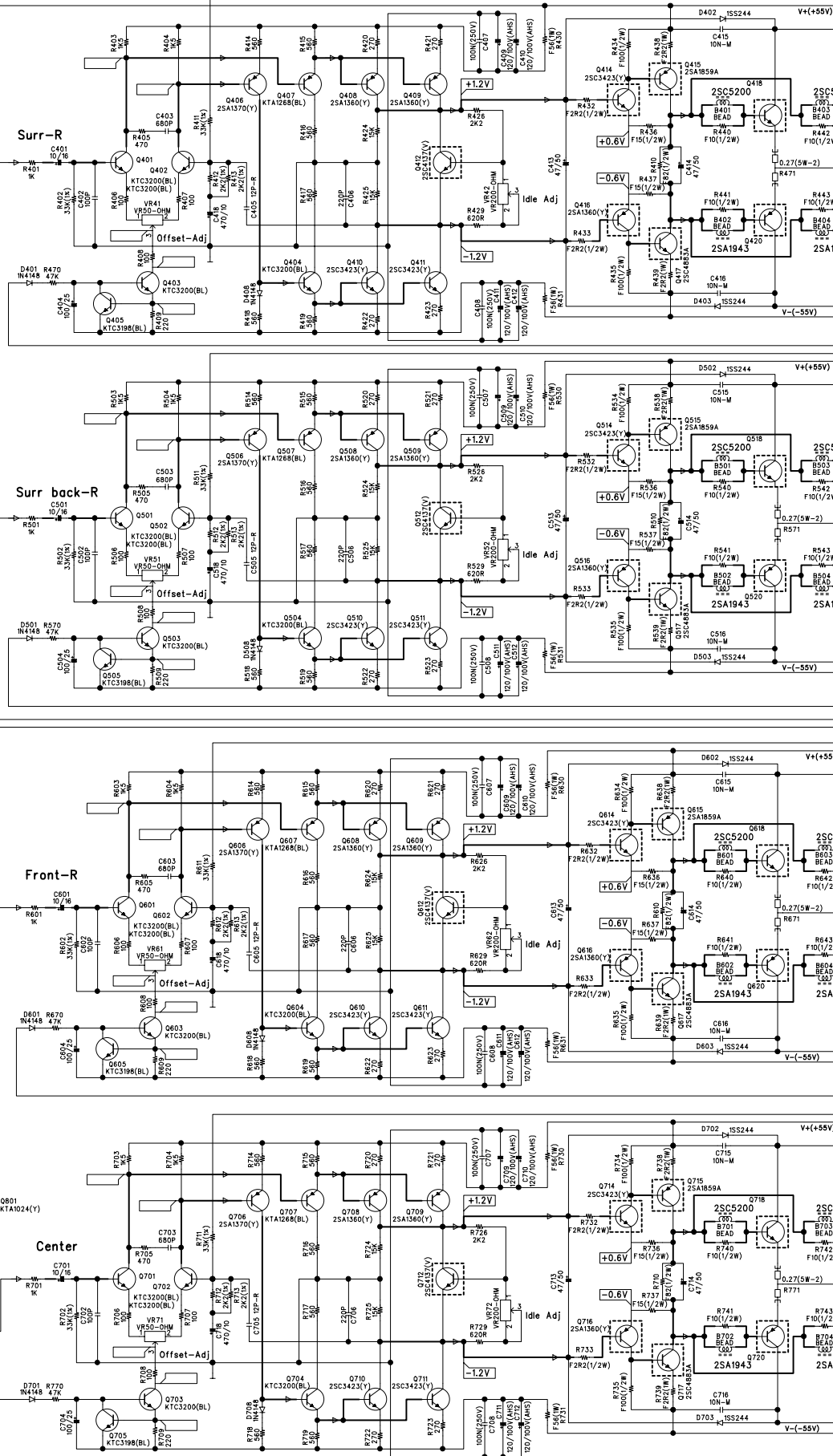

*** THE UNIT OF RESISTANCE IS OHM.
 R=1000 OHM, M=1000 OHM.
 *** THE UNIT OF CAPACITANCE IS MICROFARAD (μF)
 μ=10⁻⁶
 *** THIS SCHEMATIC DIAGRAM MAY MODIFIED AT ANYTIME WITH THE
 IMPROVEMENT OF PERFORMANCE.

REVISION RECORD		
LTR	ECO NO:	APPROVED/DATE:

TIC DIAGRAM

harman/kardon AVR7200 4CH AMP

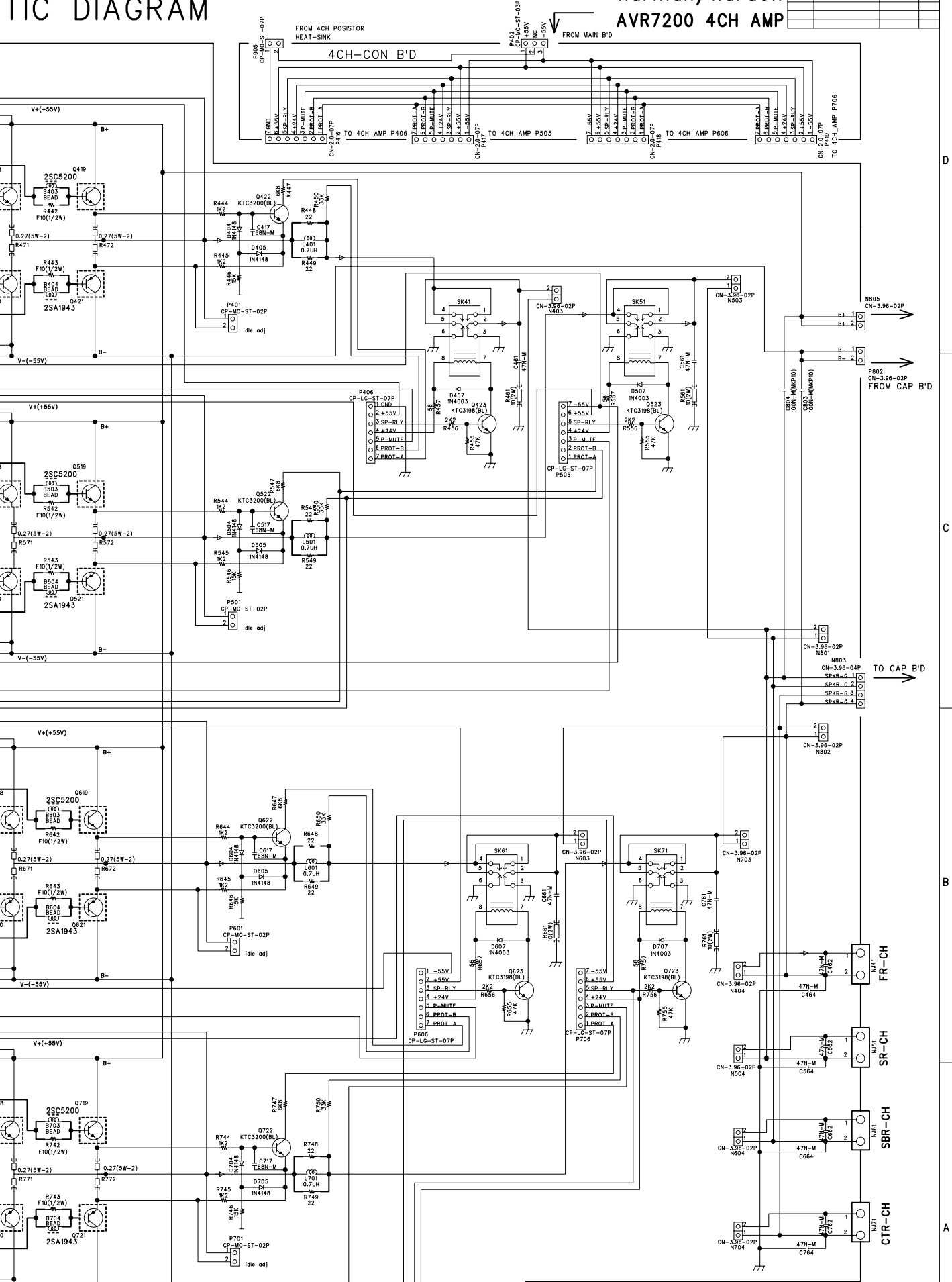

DRAWN: KIM YANG GYO		DATED: JAN.23.2003.	
CHECKED:		DATED:	
QUALITY CONTROL:		DATED:	
RELEASED:		DATED:	
COMPANY: AVR7200 4CH AMP			
TITLE:			
CODE:	SIZE:	DRAWING NO:	REV:
		55XXXXXX	A
STAGE:MP1		TOTAL SHEET: 9 OF 11	

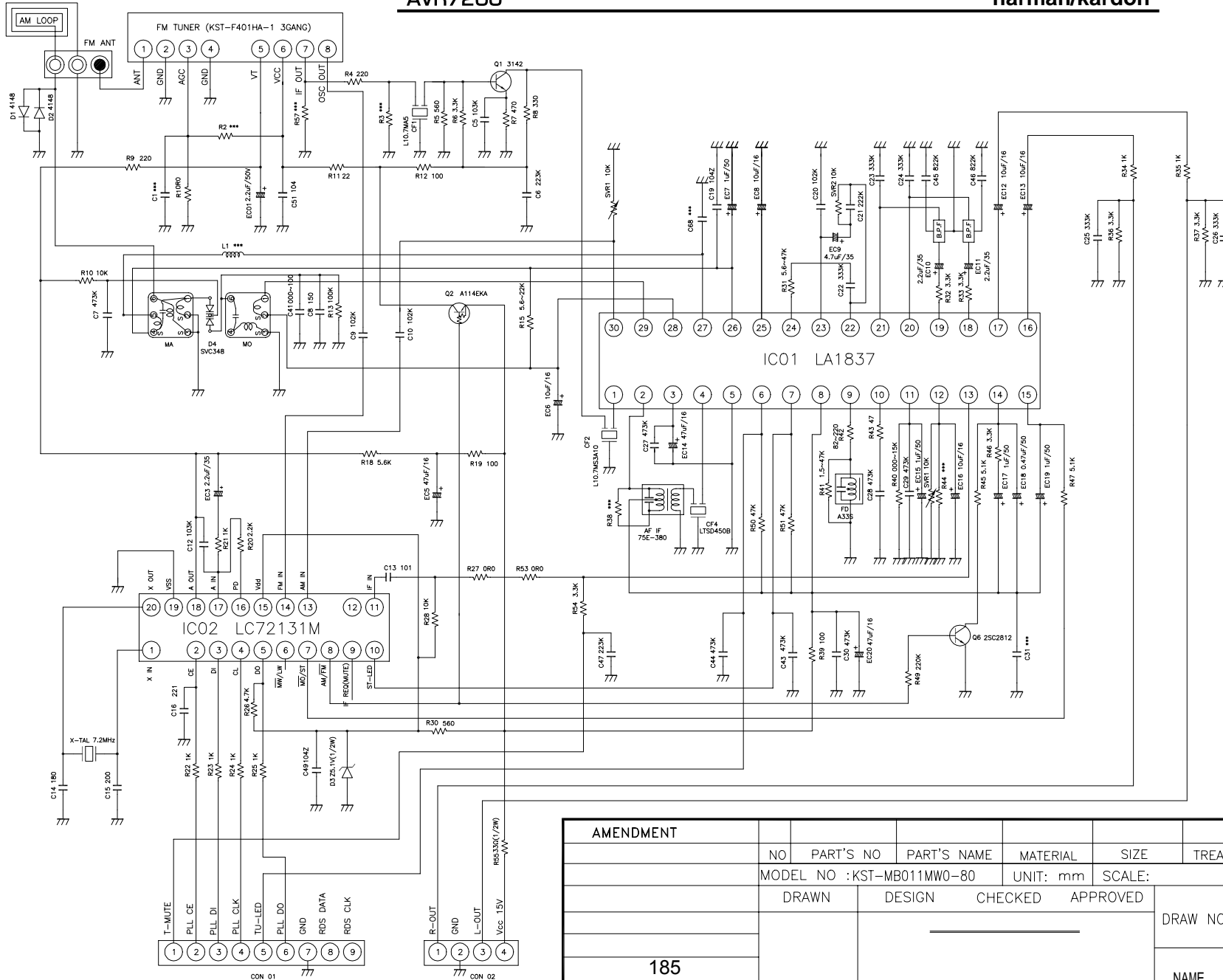

AMENDMENT

NO	PART'S NO	PART'S NAME	MATERIAL	SIZE	TREATMENT	REMARK
MODEL NO : KST-MB011MW0-80			UNIT: mm	SCALE:	DATE: 2002.07.20	
DRAWN		DESIGN	CHECKED	APPROVED	DRAW NO	KSD-M058-67
					NAME	SCHEMATIC DIAGRAM

AVR7200

harman/kardon

WIRING DIAGRAM

harman/kardon
AVR7200 WIRING

REVISION RECORD			
LTR	ECO NO:	APPROVE	DATE:

AC IN AC120V/60Hz(UL)
AC230V/50Hz(EUR)

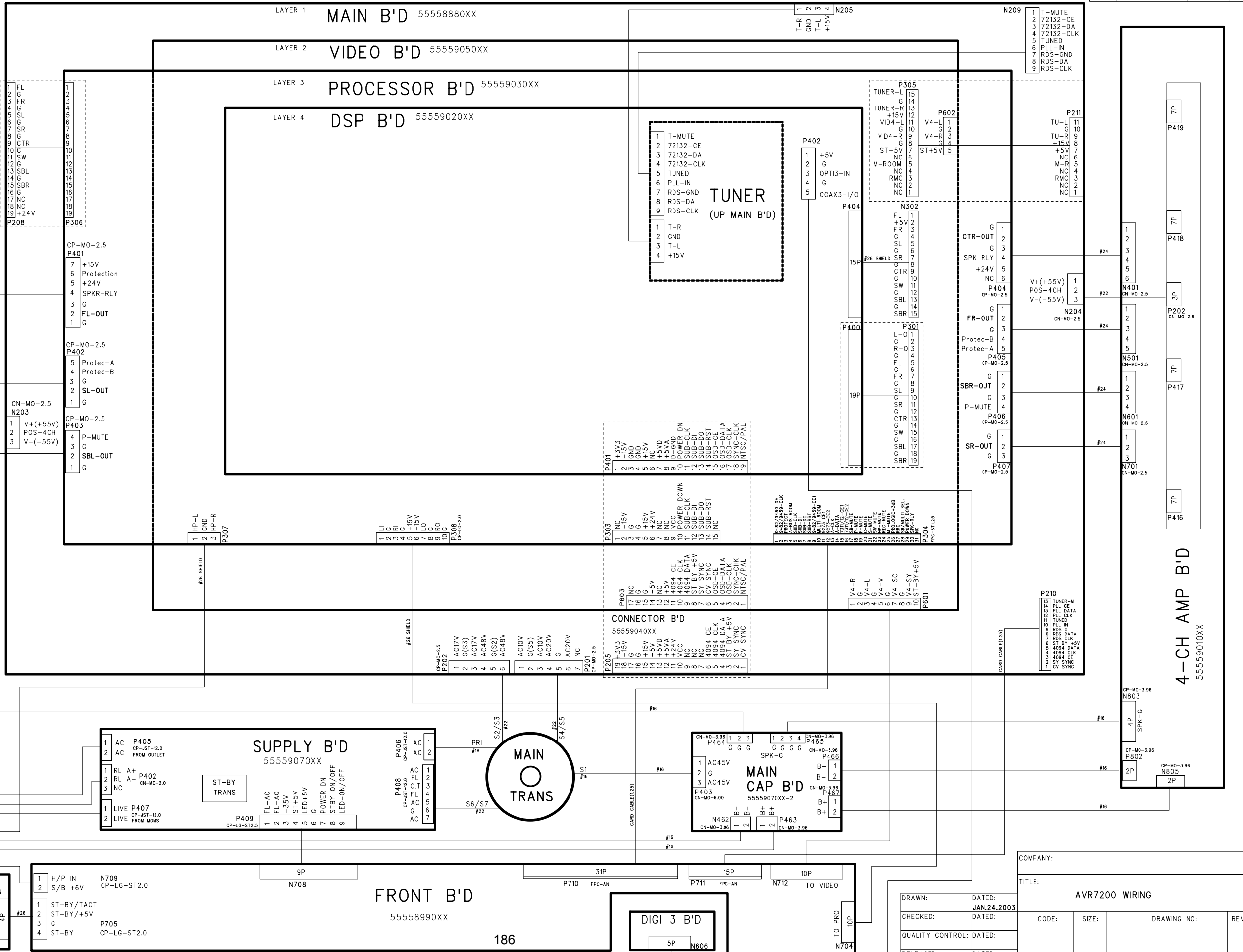

- 1 T-MUTE
- 2 72132-CE
- 3 72132-DA
- 4 72132-CLK
- 5 TUNED
- 6 PLL-IN
- 7 RDS-GND
- 8 RDS-DA
- 9 RDS-CLK

- TUNER**
(UP MAIN B'D)
- 1 T-R
 - 2 GND
 - 3 T-L
 - 4 +15V

- P402
- 1 +5V
 - 2 G
 - 3 OPTI3-IN
 - 4 G
 - 5 COAX3-I/O

- P305
- 15 TUNER-L
 - 14 G
 - 13 TUNER-R
 - 12 G
 - 11 VID4-L
 - 10 G
 - 9 VID4-R
 - 8 G
 - 7 ST+5V
 - 6 NC
 - 5 M-ROOM
 - 4 RMC
 - 3 NC
 - 2 NC
 - 1 NC

- P211
- 11 TU-L
 - 10 G
 - 9 TU-R
 - 8 +15V
 - 7 +5V
 - 6 NC
 - 5 M-R
 - 4 NC
 - 3 RMC
 - 2 NC
 - 1 NC

- P419
- 1 7P

- P418
- 1 7P

- P417
- 1 7P

- P416
- 1 7P

- P415
- 1 7P

- P414
- 1 7P

- P413
- 1 7P

- P412
- 1 7P

- P411
- 1 7P

- P410
- 1 7P

- P409
- 1 7P

- P408
- 1 7P

- P407
- 1 7P

- P406
- 1 7P

- P405
- 1 7P

- P404
- 1 7P

- P403
- 1 7P

- P402
- 1 7P

- P401
- 1 7P

- CTR-OUT
- 1 G
 - 2 G
 - 3 G
 - 4 SPKR RLY
 - 5 +24V
 - 6 NC
 - 7 P404
 - 8 CP-MO-2.5
 - 9 SBL
 - 10 SBR
 - 11 G
 - 12 FR-OUT
 - 13 G
 - 14 Protec-B
 - 15 Protec-A
 - 16 P405
 - 17 CP-MO-2.5
 - 18 G
 - 19 SBR-OUT
 - 20 G
 - 21 P-MUTE
 - 22 P406
 - 23 CP-MO-2.5
 - 24 SR-OUT
 - 25 G
 - 26 G
 - 27 G
 - 28 G
 - 29 G
 - 30 G
 - 31 G
 - 32 G
 - 33 G
 - 34 G
 - 35 G
 - 36 G
 - 37 G
 - 38 G
 - 39 G
 - 40 G
 - 41 G
 - 42 G
 - 43 G
 - 44 G
 - 45 G
 - 46 G
 - 47 G
 - 48 G
 - 49 G
 - 50 G
 - 51 G
 - 52 G
 - 53 G
 - 54 G
 - 55 G
 - 56 G
 - 57 G
 - 58 G
 - 59 G
 - 60 G
 - 61 G
 - 62 G
 - 63 G
 - 64 G
 - 65 G
 - 66 G
 - 67 G
 - 68 G
 - 69 G
 - 70 G
 - 71 G
 - 72 G
 - 73 G
 - 74 G
 - 75 G
 - 76 G
 - 77 G
 - 78 G
 - 79 G
 - 80 G
 - 81 G
 - 82 G
 - 83 G
 - 84 G
 - 85 G
 - 86 G
 - 87 G
 - 88 G
 - 89 G
 - 90 G
 - 91 G
 - 92 G
 - 93 G
 - 94 G
 - 95 G
 - 96 G
 - 97 G
 - 98 G
 - 99 G
 - 100 G

- SPK RLY
- 1 G
 - 2 G
 - 3 G
 - 4 SPKR RLY
 - 5 +24V
 - 6 NC
 - 7 P404
 - 8 CP-MO-2.5
 - 9 SBL
 - 10 SBR
 - 11 G
 - 12 FR-OUT
 - 13 G
 - 14 Protec-B
 - 15 Protec-A
 - 16 P405
 - 17 CP-MO-2.5
 - 18 G
 - 19 SBR-OUT
 - 20 G
 - 21 P-MUTE
 - 22 P406
 - 23 CP-MO-2.5
 - 24 SR-OUT
 - 25 G
 - 26 G
 - 27 G
 - 28 G
 - 29 G
 - 30 G
 - 31 G
 - 32 G
 - 33 G
 - 34 G
 - 35 G
 - 36 G
 - 37 G
 - 38 G
 - 39 G
 - 40 G
 - 41 G
 - 42 G
 - 43 G
 - 44 G
 - 45 G
 - 46 G
 - 47 G
 - 48 G
 - 49 G
 - 50 G
 - 51 G
 - 52 G
 - 53 G
 - 54 G
 - 55 G
 - 56 G
 - 57 G
 - 58 G
 - 59 G
 - 60 G
 - 61 G
 - 62 G
 - 63 G
 - 64 G
 - 65 G
 - 66 G
 - 67 G
 - 68 G
 - 69 G
 - 70 G
 - 71 G
 - 72 G
 - 73 G
 - 74 G
 - 75 G
 - 76 G
 - 77 G
 - 78 G
 - 79 G
 - 80 G
 - 81 G
 - 82 G
 - 83 G
 - 84 G
 - 85 G
 - 86 G
 - 87 G
 - 88 G
 - 89 G
 - 90 G
 - 91 G
 - 92 G
 - 93 G
 - 94 G
 - 95 G
 - 96 G
 - 97 G
 - 98 G
 - 99 G
 - 100 G

- V+ (+55V)
- 1 V+ (+55V)
 - 2 POS-4CH
 - 3 V- (-55V)

- N204
- 1 CN-MO-2.5
 - 2
 - 3
 - 4
 - 5
 - 6
 - 7
 - 8
 - 9
 - 10
 - 11
 - 12
 - 13
 - 14
 - 15
 - 16
 - 17
 - 18
 - 19
 - 20
 - 21
 - 22
 - 23
 - 24
 - 25
 - 26
 - 27
 - 28
 - 29
 - 30
 - 31
 - 32
 - 33
 - 34
 - 35
 - 36
 - 37
 - 38
 - 39
 - 40
 - 41
 - 42
 - 43
 - 44
 - 45
 - 46
 - 47
 - 48
 - 49
 - 50
 - 51
 - 52
 - 53
 - 54
 - 55
 - 56
 - 57
 - 58
 - 59
 - 60
 - 61
 - 62
 - 63
 - 64
 - 65
 - 66
 - 67
 - 68
 - 69
 - 70
 - 71
 - 72
 - 73
 - 74
 - 75
 - 76
 - 77
 - 78
 - 79
 - 80
 - 81
 - 82
 - 83
 - 84
 - 85
 - 86
 - 87
 - 88
 - 89
 - 90
 - 91
 - 92
 - 93
 - 94
 - 95
 - 96
 - 97
 - 98
 - 99
 - 100

- N401
- 1 CN-MO-2.5
 - 2
 - 3
 - 4
 - 5
 - 6
 - 7
 - 8
 - 9
 - 10
 - 11
 - 12
 - 13
 - 14
 - 15
 - 16
 - 17
 - 18
 - 19
 - 20
 - 21
 - 22
 - 23
 - 24
 - 25
 - 26
 - 27
 - 28
 - 29
 - 30
 - 31
 - 32
 - 33
 - 34
 - 35
 - 36
 - 37
 - 38
 - 39
 - 40
 - 41
 - 42
 - 43
 - 44
 - 45
 - 46
 - 47
 - 48
 - 49
 - 50
 - 51
 - 52
 - 53
 - 54
 - 55
 - 56
 - 57
 - 58
 - 59
 - 60
 - 61
 - 62
 - 63
 - 64
 - 65
 - 66
 - 67
 - 68
 - 69
 - 70
 - 71
 - 72
 - 73
 - 74
 - 75
 - 76
 - 77
 - 78
 - 79
 - 80
 - 81
 - 82
 - 83
 - 84
 - 85
 - 86
 - 87
 - 88
 - 89
 - 90
 - 91
 - 92
 - 93
 - 94
 - 95
 - 96
 - 97
 - 98
 - 99
 - 100

- N501
- 1 CN-MO-2.5
 - 2
 - 3
 - 4
 - 5
 - 6
 - 7
 - 8
 - 9
 - 10
 - 11
 - 12
 - 13
 - 14
 - 15
 - 16
 - 17
 - 18
 - 19
 - 20
 - 21
 - 22
 - 23
 - 24
 - 25
 - 26
 - 27
 - 28
 - 29
 - 30
 - 31
 - 32
 - 33
 - 34
 - 35
 - 36
 - 37
 - 38
 - 39
 - 40
 - 41
 - 42
 - 43
 - 44
 - 45
 - 46
 - 47
 - 48
 - 49
 - 50
 - 51
 - 52
 - 53
 - 54
 - 55
 - 56
 - 57
 - 58
 - 59
 - 60
 - 61
 - 62
 - 63
 - 64
 - 65
 - 66
 - 67
 - 68
 - 69
 - 70
 - 71
 - 72
 - 73
 - 74
 - 75
 - 76
 - 77
 - 78
 - 79
 - 80
 - 81
 - 82
 - 83
 - 84
 - 85
 - 86
 - 87
 - 88
 - 89
 - 90
 - 91
 - 92
 - 93
 - 94
 - 95
 - 96
 - 97
 - 98
 - 99
 - 100

- N601
- 1 CN-MO-2.5
 - 2
 - 3
 - 4
 - 5
 - 6
 - 7
 - 8
 - 9
 - 10
 - 11
 - 12
 - 13
 - 14
 - 15
 - 16
 - 17
 - 18
 - 19
 - 20
 - 21
 - 22
 - 23
 - 24
 - 25
 - 26
 - 27
 - 28
 - 29
 - 30
 - 31
 - 32
 - 33
 - 34
 - 35
 - 36
 - 37
 - 38
 - 39
 - 40
 - 41
 - 42
 - 43
 - 44
 - 45
 - 46
 - 47
 - 48
 - 49
 - 50
 - 51
 - 52
 - 53
 - 54
 - 55
 - 56
 - 57
 - 58
 - 59
 - 60
 - 61
 - 62
 - 63
 - 64
 - 65
 - 66
 - 67
 - 68
 - 69
 - 70
 - 71
 - 72
 - 73
 - 74
 - 75
 - 76
 - 77
 - 78
 - 79
 - 80
 - 81
 - 82
 - 83
 - 84
 - 85
 - 86
 - 87
 - 88
 - 89
 - 90
 - 91
 - 92
 - 93
 - 94
 - 95
 - 96
 - 97
 - 98
 - 99
 - 100

- N701
- 1 CN-MO-2.5
 - 2
 - 3
 - 4
 - 5
 - 6
 - 7
 - 8
 - 9
 - 10
 - 11
 - 12
 - 13
 - 14
 - 15
 - 16
 - 17
 - 18
 - 19
 - 20
 - 21
 - 22
 - 23
 - 24
 - 25
 - 26
 - 27
 - 28
 - 29
 - 30
 - 31
 - 32
 - 33
 - 34
 - 35
 - 36
 - 37
 - 38
 - 39
 - 40
 - 41
 - 42
 - 43
 - 44
 - 45
 - 46
 - 47
 - 48
 - 49
 - 50
 - 51
 - 52
 - 53
 - 54
 - 55
 - 56
 - 57
 - 58
 - 59
 - 60
 - 61
 - 62
 - 63
 - 64
 - 65
 - 66
 - 67
 - 68
 - 69
 - 70
 - 71
 - 72
 - 73
 - 74
 - 75
 - 76
 - 77
 - 78
 - 79
 - 80
 - 81
 - 82
 - 83
 - 84
 - 85
 - 86
 - 87
 - 88
 - 89
 - 90
 - 91
 - 92
 - 93
 - 94
 - 95
 - 96
 - 97
 - 98
 - 99
 - 100

- N803
- 1 CP-MO-3.96
 - 2 SPK-G
 - 3
 - 4
 - 5
 - 6
 - 7
 - 8
 - 9
 - 10
 - 11
 - 12
 - 13
 - 14
 - 15
 - 16
 - 17
 - 18
 - 19
 - 20
 - 21
 - 22
 - 23
 - 24
 - 25
 - 26
 - 27
 - 28
 - 29
 - 30
 - 31
 - 32
 - 33
 - 34
 - 35
 - 36
 - 37
 - 38
 - 39
 - 40
 - 41
 - 42
 - 43
 - 44
 - 45
 - 46
 - 47
 - 48
 - 49
 - 50
 - 51
 - 52
 - 53
 - 54
 - 55
 - 56
 - 57
 - 58
 - 59
 - 60
 - 61
 - 62
 - 63
 - 64
 - 65
 - 66
 - 67
 - 68
 - 69
 - 70
 - 71
 - 72
 - 73
 - 74
 - 75
 - 76
 - 77
 - 78
 - 79
 - 80
 - 81
 - 82
 - 83
 - 84
 - 85
 - 86
 - 87
 - 88
 - 89
 - 90
 - 91
 - 92
 - 93
 - 94
 - 95
 - 96
 - 97
 - 98
 - 99
 - 100

- N805
- 1 CP-MO-3.96
 - 2 P802
 - 3
 - 4
 - 5
 - 6
 - 7
 - 8
 - 9
 - 10
 - 11
 - 12
 - 13
 - 14
 - 15
 - 16
 - 17
 - 18
 - 19
 - 20
 - 21
 - 22
 - 23
 - 24
 - 25
 - 26
 - 27
 - 28
 - 29
 - 30
 - 31
 - 32
 - 33
 - 34
 - 35
 - 36
 - 37
 - 38
 - 39
 - 40
 - 41
 - 42
 - 43
 - 44
 - 45
 - 46
 - 47
 - 48
 - 49
 - 50
 - 51
 - 52
 - 53
 - 54
 - 55
 - 56
 - 57
 - 58
 - 59
 - 60
 - 61
 - 62
 - 63
 - 64
 - 65
 - 66
 - 67
 - 68
 - 69
 - 70
 - 71
 - 72
 - 73
 - 74
 - 75
 - 76
 - 77
 - 78
 - 79
 - 80
 - 81
 - 82
 - 83
 - 84
 - 85
 - 86
 - 87
 - 88
 - 89
 - 90
 - 91
 - 92
 - 93
 - 94
 - 95
 - 96
 - 97
 - 98
 - 99
 - 100

- N805
- 1 CP-MO-3.96
 - 2 P802
 - 3
 - 4
 - 5
 - 6
 - 7
 - 8
 - 9
 - 10
 - 11
 - 12
 - 13
 - 14
 - 15
 - 16
 - 17
 - 18
 - 19
 - 20
 - 21
 - 22
 - 23
 - 24
 - 25
 - 26
 - 27
 - 28
 - 29
 - 30
 - 31
 - 32
 - 33
 - 34
 - 35
 - 36
 - 37
 - 38
 - 39
 - 40
 - 41
 - 42
 - 43
 - 44
 - 45
 - 46
 - 47
 - 48
 - 49
 - 50
 - 51
 - 52
 - 53
 - 54
 - 55
 - 56
 - 57
 - 58
 - 59
 - 60
 - 61
 - 62
 - 63
 - 64
 - 65
 - 66
 - 67
 - 68
 - 69
 - 70
 - 71
 - 72
 - 73
 - 74
 - 75
 - 76
 - 77
 - 78
 - 79
 - 80
 - 81
 - 82
 - 83
 - 84
 - 85
 - 86
 - 87
 - 88
 - 89
 - 90
 - 91
 - 92
 - 93
 - 94
 - 95
 - 96
 - 97
 - 98
 - 99
 - 100

- N805
- 1 CP-MO-3.96
 - 2 P802
 - 3
 - 4
 - 5
 - 6
 - 7
 - 8
 - 9
 - 10
 - 11
 - 12
 - 13
 - 14
 - 15
 - 16
 - 17
 - 18
 - 19
 - 20
 - 21
 - 22
 - 23
 - 24
 - 25
 - 26
 - 27
 - 28
 - 29
 - 30
 - 31
 - 32
 - 33
 - 34
 - 35
 - 36
 - 37
 - 38
 - 39
 - 40
 - 41
 - 42
 - 43
 - 44
 - 45
 - 46
 - 47
 - 48
 - 49
 - 50
 - 51
 - 52
 - 53
 - 54
 - 55
 - 56

PACKAGE

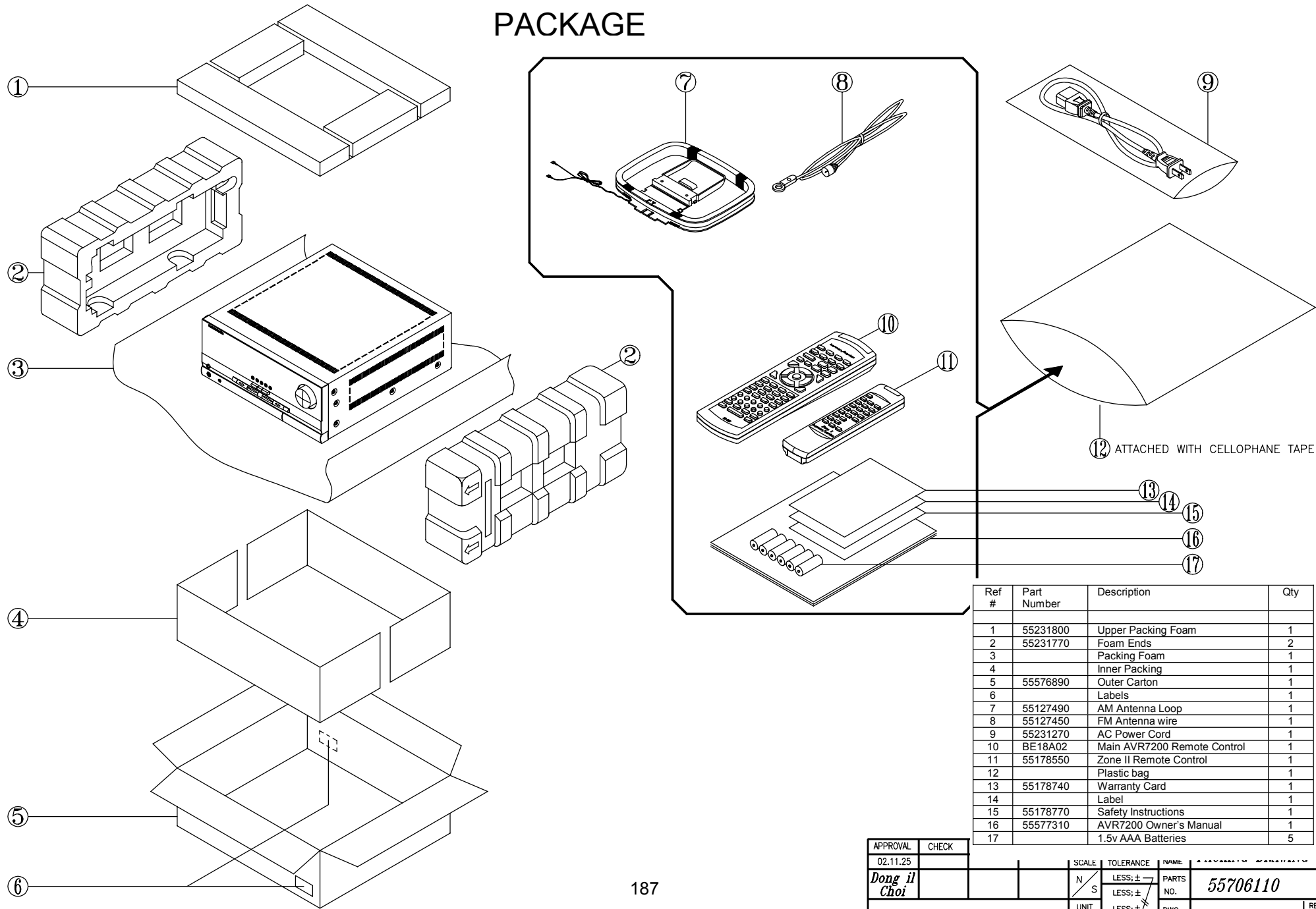

Ref #	Part Number	Description	Qty
1	55231800	Upper Packing Foam	1
2	55231770	Foam Ends	2
3		Packing Foam	1
4		Inner Packing	1
5	55576890	Outer Carton	1
6		Labels	1
7	55127490	AM Antenna Loop	1
8	55127450	FM Antenna wire	1
9	55231270	AC Power Cord	1
10	BE18A02	Main AVR7200 Remote Control	1
11	55178550	Zone II Remote Control	1
12		Plastic bag	1
13	55178740	Warranty Card	1
14		Label	1
15	55178770	Safety Instructions	1
16	55577310	AVR7200 Owner's Manual	1
17		1.5v AAA Batteries	5

APPROVAL	CHECK
02.11.25	

Dong il Choi	N	SCALE	TOLERANCE	NAME	PARTS NO.	55706110	REV. NO.	0
		UNIT	LESS: ±	DWG. NO.				
	S	m/m	LESS: ±					